



**SAVE up to 50% in
MATERIALS & GAS**

A FLOW WRAPPER WITH POSITIVE VACUUM & GAS CONTROLLED FLUSH

MasterPACKer®

Fast & Efficient

Multiple Sustainable Package Options

Exponential Labor Savings

User Friendly

Excellent ROI

- ▶ Hi-Velocity Snorkel System for superior vacuum / gas flush control
- ▶ Low & High O2 Options
- ▶ Precision with servo motors & timing belts
- ▶ Dual impulse seal bar
- ▶ Fast & controlled bag feeding
- ▶ Patented Eco friendly film management
- ▶ Complete processing system integration
- ▶ Small footprint

+ 1-847-741-3500
sales@cv-tek.com
www.cv-tek.com



High speed loading for all case ready applications

ARTISAN BREAD

HAMBURGER & HOT DOG BUNS

HOAGIE & SUB ROLLS

CASE READY MEAT

FOOD SERVICE BACON

MasterPACKer AUTOMATED MAP MACHINES

The MasterPACKer® is a fast and efficient, fully automated modified atmosphere packaging system which is used for retail ready mother bag production. This compact machine automatically inserts pre-wrapped trays into mother bags at speeds up to 12 bags per minute.

PLC controls ensure consistent vacuum and gas levels while providing maximum flexibility. The ability to change to double and triple layers is automatic with the touch-screen control panel.



Infeed Conveyor



Vacuum Gas Flush



Master Bag

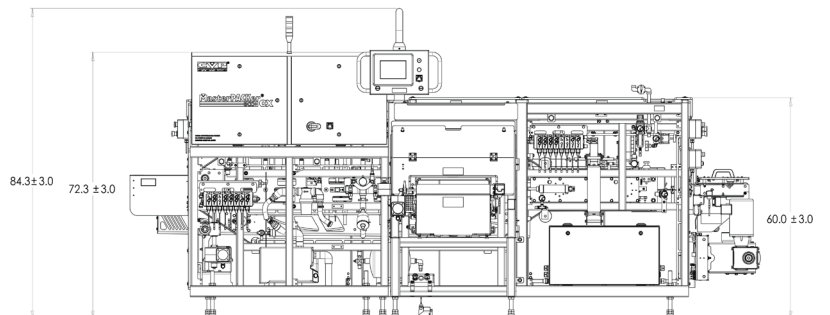
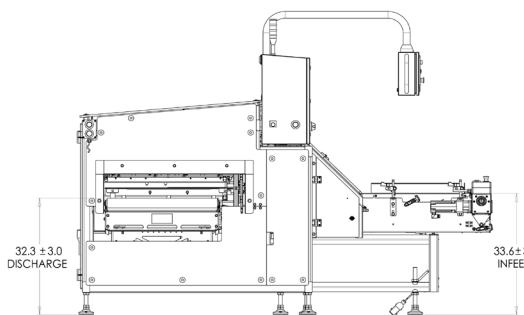
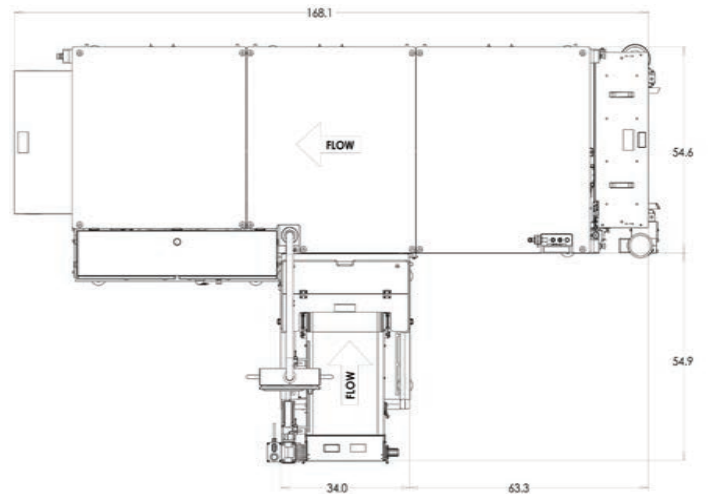

- ▶ Dual Gas Accumulator Tanks for High and Low O₂
- ▶ Infeed conveyor with servo controlled linear actuators for fast and controlled feeding of bags
- ▶ Various bag widths from 15" to 30"
- ▶ Capable of full integration with robotic pick and place systems or other feeding systems