



Corrvac® MAP-VAC

**Manual Prepared for:**

*Company:*

*Location:*

*Pylon#:*

*Customer PO#:*

*Order Date:*

*Total Binders:*      *of*





## Corr-Vac® MAP-VAC

### Hot Bar & Impulse Machine Manual

*This page has been left blank intentionally*

# Table of Contents

<b>CHAPTER 1: MACHINE SPECIFICATIONS</b> .....	<b>1-1</b>
<b>1.1. Machine Specifications</b> .....	<b>1-2</b>
C -TEK Model .....	1-2
Serial Number .....	1-2
Year of Manufacture.....	1-2
Electrical Requirements .....	1-2
Minimum Compressed Air Requirements.....	1-2
Maximum Compressed Air Requirements.....	1-2
Minimum Compressed Gas Requirements .....	1-2
Maximum Compressed Gas Requirements .....	1-2
<b>CHAPTER 2: CUSTOMER SERVICE</b> .....	<b>2-1</b>
<b>2.1. Spare Parts</b> .....	<b>2-2</b>
<b>2.2. Technical Assistance</b> .....	<b>2-2</b>
<b>2.3. Preventative Maintenance</b> .....	<b>2-2</b>
<b>CHAPTER 3: GENERAL INFORMATION</b> .....	<b>3-1</b>
<b>CHAPTER 4: SAFETY</b> .....	<b>4-1</b>
<b>4.1. Operating the Machine</b> .....	<b>4-2</b>
<b>4.2. Using this Manual</b> .....	<b>4-3</b>
<b>4.3. Door Opening Instructions</b> .....	<b>4-4</b>
<b>4.4. Door Closing Instructions</b> .....	<b>4-5</b>
<b>4.5. Locking Castors – Installation</b> .....	<b>4-6</b>
<b>CHAPTER 5: INSTALLATION</b> .....	<b>5-1</b>
<b>5.1. General Delivery Notes</b> .....	<b>5-2</b>
Inspection.....	5-2
<b>5.2. Unloading and Positioning the Machine</b> .....	<b>5-3</b>
Removing the Crate .....	5-3
Head Position.....	5-5
Technical Assistance .....	5-7
<b>5.3. Service Connections</b> .....	<b>5-8</b>
Power Supply .....	5-8
Pump Rotation .....	5-9
Compressed Air .....	5-10
Gas Supply .....	5-10
<b>CHAPTER 6: CONTROLS</b> .....	<b>6-1</b>
<b>6.1. Control Panel (Operator Interface)</b> .....	<b>6-2</b>
<b>6.2. Programming</b> .....	<b>6-3</b>

VAC.....	6-5
SOAK.....	6-5
GAS .....	6-6
PAUSE.....	6-6
Examples .....	6-7
Programming Summary .....	6-8
<b>6.3. Operation.....</b>	<b>6-9</b>
Hot Bar Equipped Display .....	6-9
Impulse Equipped Display.....	6-9
Program Selection (All Versions) .....	6-9
Emergency Stop Button .....	6-10
Cycle/Heat Seal Button .....	6-11
Clean Cycle Button .....	6-11
Supervisor's Key .....	6-11
<b>6.4. Vacuum Programming Options .....</b>	<b>6-12</b>
<b>6.5. Troubleshooting Controls .....</b>	<b>6-13</b>
Fault Messages.....	6-14
Vacuum Control Circuit .....	6-15
Heat-Sealer Control .....	6-15
Sealer Bar Cold.....	6-15
Sealer Bar Overheated .....	6-16
Impulse Sealer Control.....	6-16
Impulse Band Control.....	6-17
Sealer Bar Overheated .....	6-17
Impulse Band – Premature Failure.....	6-17
<b>6.6. Operator Interface/PLC Checks .....</b>	<b>6-19</b>
Controller Menu Screen .....	6-19
Controller Status Screen .....	6-19
<b>6.7. Machine Configuration Mode Procedure .....</b>	<b>6-20</b>
Configuration Screens.....	6-20
Total Cycles Screen .....	6-20
Cycle Probes Screen .....	6-20
Cycle Jaw Screen .....	6-20
Cycle Seal Bar Screen .....	6-21
Cycle Vacuum Valve Screen.....	6-21
Cycle Gas Valve Screen .....	6-21
Cycle Gas 2 Valve Screen .....	6-21
Cycle Exit Conveyor Screen .....	6-21
System Scale Screen.....	6-22
Number of Probes Screen.....	6-22
Motor/Piab Vacuum Screen .....	6-22
Vacuum Valve Type Screen.....	6-22
Low Gas Detect Screen .....	6-23
Jaw Type Screen .....	6-23
Pump Off Delay Screen .....	6-23

Timed Exit Conveyor Screen .....	6-23
Jaw Opened Delay Screen .....	6-23
Bag Stretcher Screen.....	6-24
Run Key Enable/Disable Screen .....	6-24
2nd Gas Valve Screen .....	6-24
3rd Bag Stretcher Switch Screen .....	6-24
Conveyor Run Time Screen.....	6-24
<b>6.8. I/O Status View Procedure .....</b>	<b>6-25</b>
I/O Status Screens.....	6-25
I/O Status Screen Input 1 .....	6-25
I/O Status Screen Input 2.....	6-25
I/O Status Screen Input 3.....	6-25
I/O Status Screen Output 1 .....	6-25
I/O Status Screen Output 2 .....	6-26
I/O Status Screen Output 3 .....	6-26
<b>6.9. Display Hidden Buttons.....</b>	<b>6-27</b>
<b>CHAPTER 7: PREVENTATIVE MAINTENANCE.....</b>	<b>7-1</b>
<b>7.1. Daily Checks.....</b>	<b>7-2</b>
<b>7.2. Daily Cleanup .....</b>	<b>7-3</b>
<b>7.3. Weekly Checks .....</b>	<b>7-4</b>
<b>7.4. As Needed .....</b>	<b>7-4</b>
<b>CHAPTER 8: MAINTENANCE AND REPAIR.....</b>	<b>8-1</b>
<b>8.1. Machine Components Identification .....</b>	<b>8-2</b>
10 cfm Vacuum Pump Service.....	8-2
21 cfm Vacuum Pump Service.....	8-2
28/35 cfm Vacuum Pump Service .....	8-3
Water-Ring Vacuum Pump Service (All Models).....	8-3
Electric Vacuum Pump Removal.....	8-3
Thermocouple Replacement (Hot-bar Sealers Only) .....	8-4
Head Bearings Lubrication.....	8-4
Flow Controls (Air Cylinders) .....	8-5
Vacuum and Air Pressure Fittings.....	8-5
Silicone Rubber Parts Service .....	8-5
Heat Sealer Bar Teflon® Tape Service (Hot Bar) .....	8-6
Impulse Heat Sealer Service.....	8-7
Automatic Jaw Opener Adjustment.....	8-8
<b>CHAPTER 9: ELECTRICAL SCHEMATICS AND BULLETINS .....</b>	<b>9-1</b>

## Chapter 1: Machine Specifications

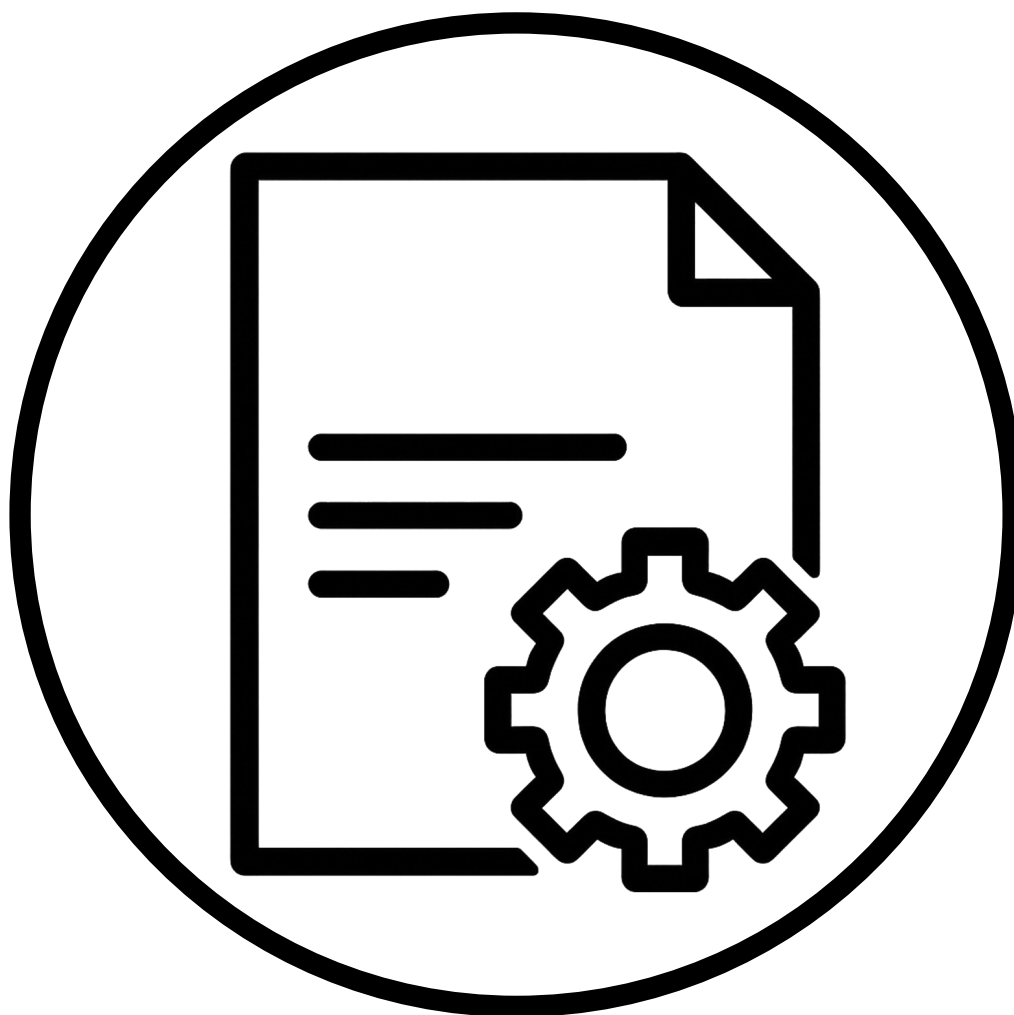

## 1.1. MACHINE SPECIFICATIONS

**CV-TEK Model**

---

**Serial Number**

Head(s)

---

**Year of Manufacture**

---

**Electrical Requirements**

---

**Minimum Compressed Air Requirements**

---

**Maximum Compressed Air Requirements**

---

**Minimum Compressed Gas Requirements**

---

**Maximum Compressed Gas Requirements**

---

**Chapter 2: Customer Service**



Thank you for purchasing the C -TEK Corr-vac® MAP AC. When you need spare parts or service, please contact us at 847.741.3500

## 2.1. SPARE PARTS

When ordering spare parts, please have the following information ready:

- Machine serial number
- Part numbers and exact description of the items required
- Quantity required
- Date required and any special shipment request
- Delivery address
- Purchase request/order reference

## 2.2. TECHNICAL ASSISTANCE

When requesting technical assistant, please have the following information ready:

- Machine serial number
- Description of the problem
- Address and telephone number
- Contact name

## 2.3. PREVENTATIVE MAINTENANCE

For details about the preventative maintenance service we offer, please call our technical service manager directly at 847.741.3500

## Chapter 3: General Information

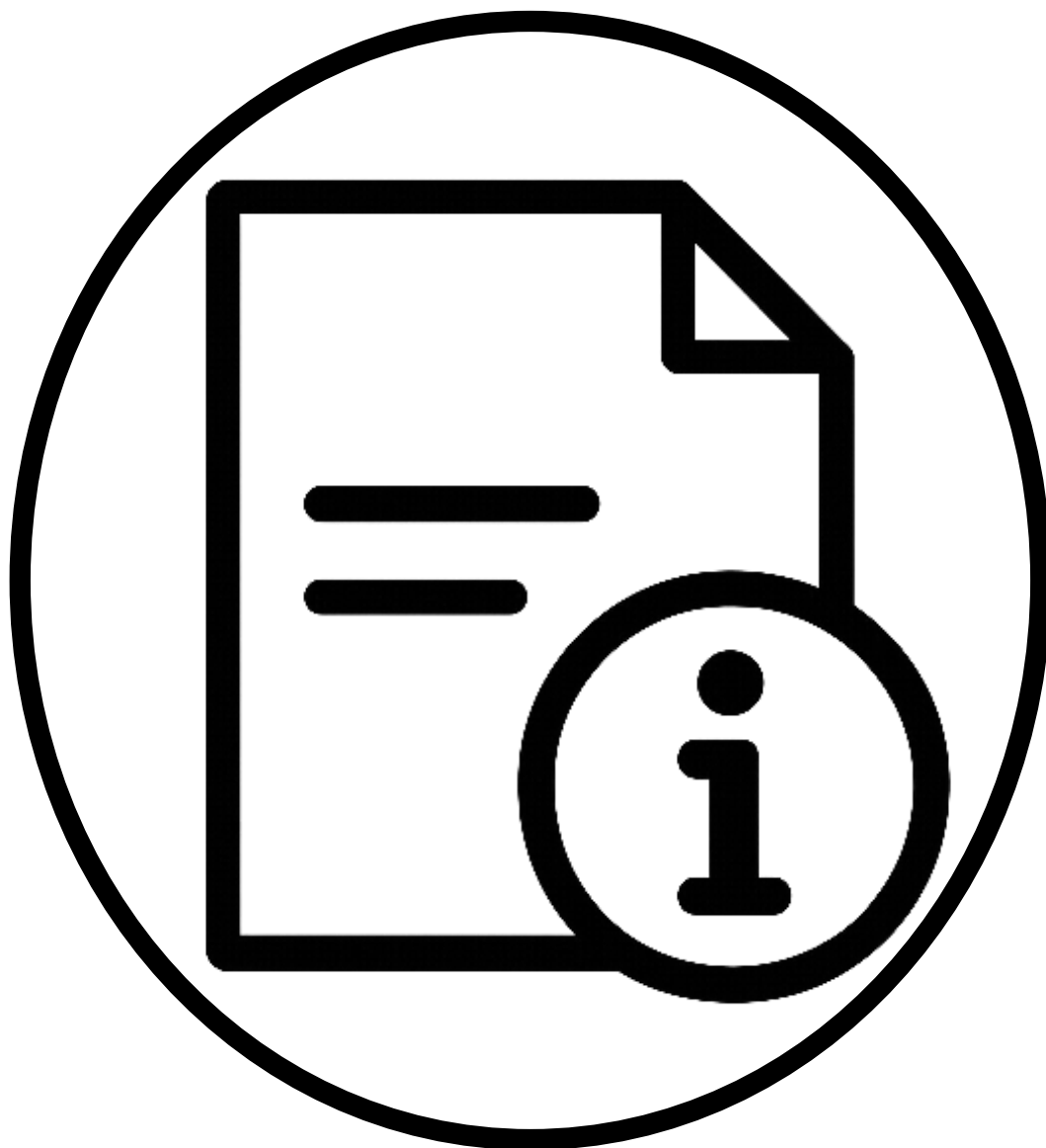

The information in this manual will assist you in getting the best from your Corr-vac® MAP AC. The text accurately describes the original build specification, but the drawings and illustrations are intended for general reference only and are not necessarily accurate in every detail. Dimensions and characteristics are not to be considered binding and may be changed without prior notice.

The user is responsible for updating the manual with any bulletins from C-TEK and to reflect any changes or modification he may make. C-TEK cannot be held responsible for the conditions of use and changes to the machine, which is beyond its control.

Please read the manual in conjunction with our conditions of sale, including those limiting warranties and remedies, which apply to all goods supplied to us. Neither the information given in this manual or the machine to which it refers are intended for any use which would violate or infringe the 'rights of' and 'statutory obligations to' third parties.

No parts of this manual or any other documents supplied with this machine may be reproduced or transmitted without prior written consent of C-TEK, Inc.

## Chapter 4: Safety



Before working with any Corr-vac® machine, you should carefully read the manual. If you are not certain that you completely understand at any point which might affect the safe and/or reliable operation of this machine, do not proceed without getting competent assistance!

## 4.1. OPERATING THE MACHINE

**The following points are strictly forbidden:**

1. Do not operate this machine in an unsafe manner, for purposes other than those for which it has been designed and intended.
2. Do not connect the machine to any energy sources (electricity, compressed air and/or gas) unless the machine is fully assembled, with all protection and safety devices properly installed. This includes proper electrical grounding of the machine.
3. Do not turn on the electrical power at the machine if the rear doors are not closed and latched.
4. Do not use any gas or gas mixture containing anything but Carbon Dioxide or Nitrogen, in a standard Corr-vac® machine. Use of poisonous, flammable or explosive gases is specifically prohibited.
5. Do not use any gas or gas mixture containing more than 21% Oxygen (by volume) unless the machine is specifically built for this purpose (designated by –O at the end of the machine's serial number).
6. If the machine is used with a high-Oxygen gas mixture, ensure that your supply hoses, pressure regulators, valves, etc. are suitable for Oxygen service.
7. Do not perform any maintenance, adjustments, repairs, etc. on this machine without first cutting off all energy sources. If this is impossible because of the work requirements, take all necessary precautions to protect yourself from injury.
8. Do not operate the machine if any guards, interlocks, or other safety devices are out of adjustment, broken, or missing. Under no circumstances should any of these devices be modified in any way.
9. Do not use two operators for a machine in order to avoid any possibility that one operator might accidentally start a machine function which would endanger the other operator.
10. Disconnect the machine from all energy sources when it is not being used.

## 4.2. USING THIS MANUAL

Throughout this manual the reader's attention is drawn to specific safety instructions as follows:



### **Warning!**

A warning alerts the reader to a potential hazard. Failure to read and comply with the safety instructions may result in death or injury of personnel and damage to the machine or product.

### **Caution!**

A caution alerts the reader to recommendations or instructions. The non-observance of which could cause damage to the machine or product.

### **Note:**

A note provides additional information which should be given special attention.

### 4.3. DOOR OPENING INSTRUCTIONS



#### **Warning!**

- ☑ You cannot open the door unless the rotary disconnect switch is “OFF”
- ☑ To close the door, the rotary disconnect switch must be “OFF”, and the exterior red handle must also be in the “OFF (horizontal) position

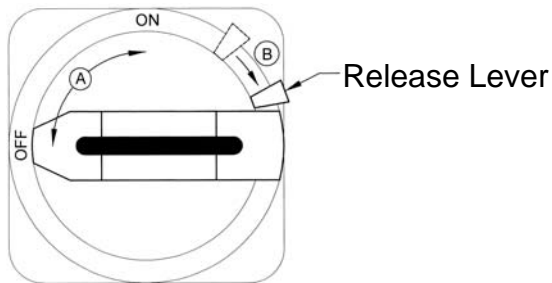

To open the upper cabinet door, follow these steps:

1. Release the black door latches, by turning them counter-clockwise, one quarter turn, to a vertical position.
2. On the red and yellow rotary electrical disconnect switch:
  - Ensure that the red handle is in the "OFF" (horizontal) position
  - Hold the release lever down, as you open the door

## 4.4. DOOR CLOSING INSTRUCTIONS

To close the upper cabinet door, follow these steps:

1. On the red and yellow rotary electrical disconnect switch:
  - Ensure that the red handle is in the "OFF" (horizontal) position
  - Hold the release lever down, as you close the door (or the disconnect switch shaft will not enter the back of the door assembly)
2. Close the black door latches, by turning them clockwise, one quarter turn, to a horizontal position.



### Warning!

- ☑ You cannot open the door unless the rotary disconnect switch is "OFF" and the release lever is held down
- ☑ To close the door, the rotary disconnect switch must be "OFF", and the exterior red handle must also be in the "OFF (horizontal) position and the release lever must be held down

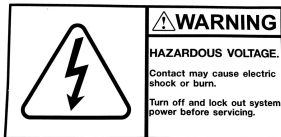

## 4.5. LOCKING CASTORS – INSTALLATION

Screw the castor's threaded stud up through the machine leg until the top of the castor is tight against the underside of the leg, then turn the lock nut tight against the top of the leg.

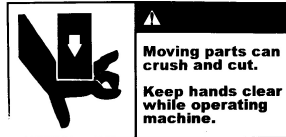

### Warning!

Never install the lock nut under the leg, as this will put more stress on the castor stud. Failure of this stud could cause the machine to tip over.

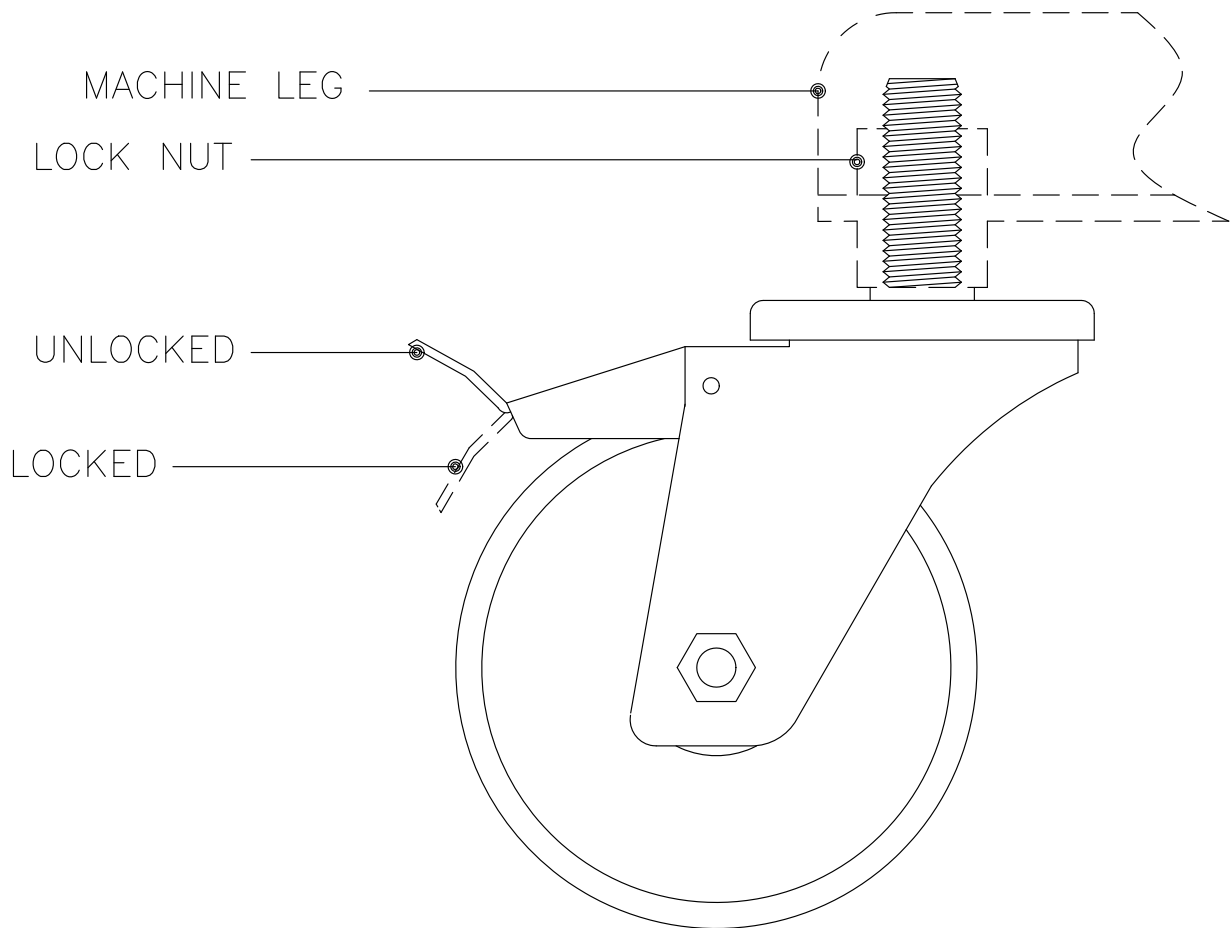

## Chapter 5: Installation



## 5.1. GENERAL DELIVERY NOTES

The machine is usually delivered on a wooden pallet with open wooden sides and top, attached with spring clips and covered in film to prevent it from being damaged during transportation.

Following receipt, check the machine condition; any damage should be communicated as soon as possible to the shipping agent by written notice.

### **Inspection**

On delivery, always check the machine and equipment for any damage. Any damage must be notified in writing as soon as possible to the carrier or to the carrier's insurance company.

## 5.2. UNLOADING AND POSITIONING THE MACHINE

If this is your first Corr-vac® MAP AC we strongly advise you to let an C-TEK representative (or authorized agent) remove the crate, assemble the machine, attach a power supply and check the machine prior to putting it into service. Our representative will then train your personnel in safe operating procedures, troubleshooting and maintenance.



### **Warning!**

Great care must be taken to assure safe handling. Always:

- Comply with the handling instructions
- Move the machine slowly
- Guarantee safety around the machine during these operations
- The machine should not be lifted without adequate equipment and the presence of skilled personnel

The machine should be moved to the desired position by using the wooden crate to which it is secured, so as to ensure better balancing and avoid damage during transportation.

Extreme care should be taken when using fork trucks. Check that the lifting capacity is sufficient before moving the machine. Make sure the forks are correctly positioned within the spaces provide in the wooden crate. Always make sure that the machine weight is correctly balanced with respect to the lifting point.

### **Removing the Crate**

Crating will vary somewhat, depending upon the machine model and the options included. However, certain similarities will be found with all crating.

1. Remove the crate-top by first unsnapping the metal clips around the edges of the top face. Then carefully lift off the crate-top.
2. Remove the front and rear faces of the crate by unsnapping the metal clips around each face and then removing each face.
3. Before removing the end-faces, first remove the bolts which connect both faces to the wooden cross-bar in the crate. Then unsnap the remaining metal clips and remove both end-faces.
4. Remove the plastic film from around the machine.
5. Remove the wooden cross-bar from the machine.

6. Remove any parts or accessories which may have been taped to the exterior of the machine.
7. Open the doors at the back of the machine and remove all parts which are packed inside. Close and securely latch the doors.
8. Remove the bolts which fasten the machine to the base of the crate.
9. Un-wrap the machine 'feet' or optional castors packed inside the machine.



**Warning!**

The drawing below shows how the feet or castors must be installed. Where castors are used, the threaded shaft on the castor must be turned all the way in, until the body of the castor is tight against the underside of the machine leg, as shown.

The locking nut must only be installed on top of the leg, never under the leg! Incorrect installation can cause breakage of the castor, which could permit the machine to tip over.

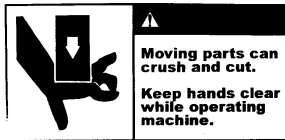
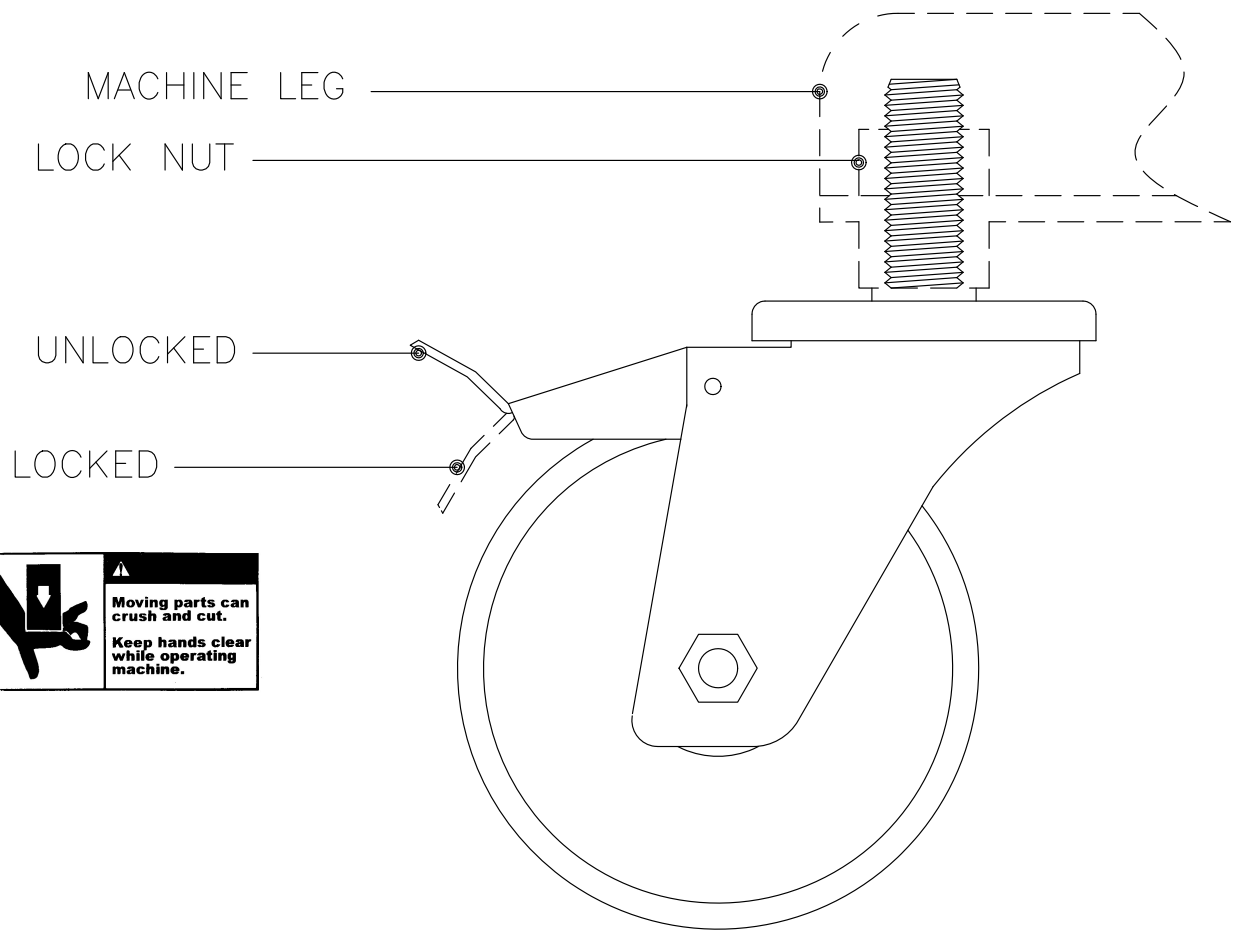

10. Lift the machine off the crate base and install the feet. The perimeter of the cabinet is reinforced so that lifting may be done at any point.



**Warning!**

The machine should not be lifted without adequate equipment, and skilled personnel.

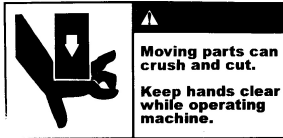

### Head Position

If you are processing top-loaded packages, it is usually best for the operator if the machine head can be mounted at the approximate height of the operator's shoulders.

For processing end-loaded bags, the most comfortable operating height is usually around 37 inches/940 mm from the bottom of the head to the floor.

The distance between the head and the packaging conveyor will be determined by the product and packaging geometry.



**Warning!**

If the height of the head must be changed, exercise extreme caution and carefully follow these instructions. You will be required to lift and accurately position the machine head, which can weigh as much as 220 lbs. /100 kg.

Do not attempt the following steps without adequate equipment and skilled personnel.

1. Ensure that the wooden lifting cradle is securely in place on the head. It will help to stabilize and protect the head while it is being moved.
  - Also ensure that the jaw is securely wedged shut with the wooden shipping wedge or fastened shut with tape, wire, etc.
2. If the head is mounted to the machine body with simple head spacers, they can remain attached to the head throughout the moving procedure.
  - If the machine is equipped with a HI-LO/joystick head mount, this head mount must be removed before the head position is changed

3. Before proceeding, study the “Head Mount” drawing below. Particularly note the position of the screws, washers, and nuts which secure the various head mounts to the machine body. It is essential that you reinstall these parts in the correct order. The shear bolts are specially made and should never be replaced with anything but a factory-supplied part.

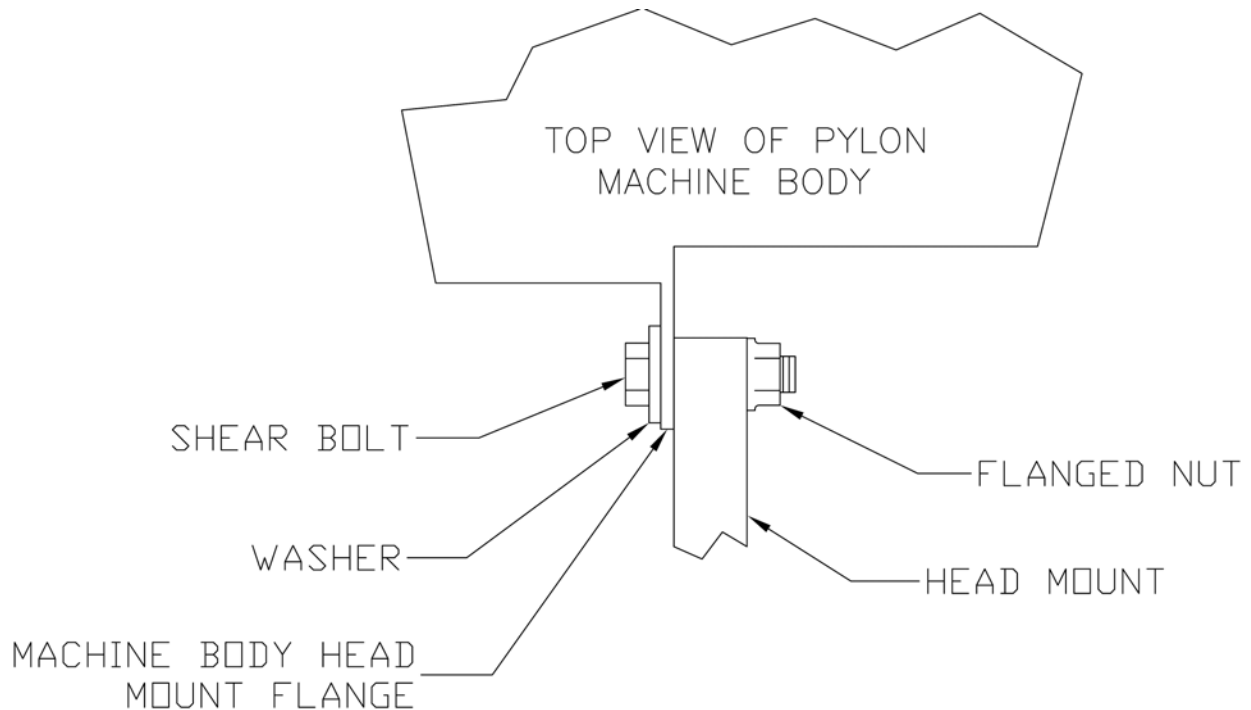

4. If the machine is equipped with castors, securely lock all of them.
5. Slide the forks of a fork-lift all the way under the wooden lifting cradle, being careful not to strike the machine body. Gently raise the forks until they are just supporting the head.
6. If the machine has a HI-LO/joystick head mount, remove the two screws which secure the head mount to the back of the head. Then pull the head away from the machine, approximately 1 inch/25 mm. This should disengage the two mounting pins which extend rearward from the back of the head, into matching holes in the head mount.



**Warning!**

The HI-LO/joystick head mount weighs 70 lbs. /32 kg. Do not attempt to remove it from the machine body without adequate personnel to securely hold it.

7. Remove the shear bolts which secure the head mount to the machine body. Reposition the head mount at the desired height and reattach it to the body.

8. Move the head up/down to match the new height of the head mount. Slide the head toward the head mount until the two mounting pins engage. Then secure the head to the head mount with the two screws.
9. If the machine only has head spacers, detach the head spacers from the machine body. Then pull the head just far enough forward for the spacers to be clear of the body.
10. Move the head up/down to the desired height. Push the head back toward the machine body and properly re-secure the head spacers to the body.

### **Technical Assistance**

For immediate technical assistance, please contact an C -TEK machinery specialist at 847-741-3500

## 5.3. SERVICE CONNECTIONS

### Power Supply

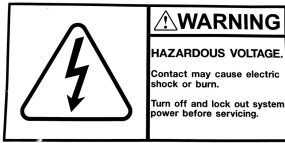

#### **Warning!**

Electrical work should only be performed by trained personnel. It is your responsibility to ensure that connective wiring meets all code requirements.

1. Review the electrical drawings in this manual to determine what electrical supply will be needed. You will also find this information on a sticker inside the door of the machine's electrical enclosure.
2. There is a cord compression fitting on the left end-wall (as viewed from the machine's front) of the machine body. Bring your electrical cable through this fitting. Tighten the fitting so that it securely grips the cable, as well as creating a water-tight seal (note that there are two sizes of sealing grommets provided for different cable sizes).
3. Connect the power wiring into the terminals at the top of the main electrical disconnect switch.



#### **Warning!**

It is essential that a reliable ground (earth) wire be connected to the machine's grounding lug, located above the main disconnect.

4. Before energizing the machine's main electrical disconnect switch, take a voltmeter and carefully check the power at the terminals on top of the switch.
  - Check power between any terminal and the machine body to verify that the ground (earth) is working
  - Check power between all terminals to verify that all phases have the correct voltage

#### **Note:**

In some power systems, one phase (often called a 'wild leg') will have a higher voltage to ground. On three-phase machines, this phase should be connected at L3. On single-phase machines, it is desirable to avoid this phase if possible.

5. Before energizing the machine, first open the machine jaw. Then energize the main disconnect switch.

- Check that the EMERGENCY STOP BUTTON is illuminated (if it is not, pull it out to its normal operating position). This indicates that the machine's control system is receiving power
- If the machine contains a vacuum pump operating on three-phase power, the motor rotation must now be checked



**Warning!**

If the pump is allowed to run backwards for more than a few seconds, it may either trip the overload protector, blow a fuse, or even damage the pump.

**Pump Rotation**

1. Remove one of the plastic vacuum tubes at a vacuum probe.
2. Briefly close the machine jaw to start the vacuum pump. If you feel pressure at the end of the plastic tube (instead of vacuum), immediately press the EMERGENCY STOP BUTTON to stop the pump, as it is running backwards.

For all models, the pump motor rotation can be reversed at the motor starter/overload protector inside the machine body.

- Turn off the power at the main electrical disconnect switch
- Locate the three wires coming out of terminals at the bottom of the motor starter/overload protector unit. Reverse the location of any two of these wires to reverse the motor direction
- Turn on the power to the machine and retest to verify that the pump is running correctly

## Compressed Air



### Warning!

Compressed air can be dangerous. Ensure that all connections are made by trained personnel using adequate parts and materials.

1. The filter/regulator/lubricator (FRL) unit is mounted on the left end-wall (as viewed from the machine's front) of the machine body. Check the MACHINE SPECIFICATIONS section of this manual for compressed air requirements.



### Warning!

Under no circumstance should compressed air be supplied to the machine at pressure above 125 psi / 8.5 bar. Over-pressure may cause mechanical failure in the FRL and could be dangerous.

2. Compressed air should be supplied to the inlet port (left-hand end) in the FRL.
3. Set the FRL pressure regulator as follows:
  - All sealers except 61 ½ inch / 1560 mm: 100 psi / 6.8 bar
  - 61 ½ inch / 1560 mm sealers: 110 psi / 7.5 bar

## Gas Supply



### Warning!

Compressed gas can be dangerous. Ensure that all connections are made by trained personnel, using adequate parts and material. If you are using gas cylinders, be sure that they are properly secured and cannot fall over.

All gas connections are located on the right end wall (as viewed from the machine's front) of the machine body. Check the MACHINE SPECIFICATIONS section of this manual for compressed gas requirements.



### Warning!

Under no circumstances should compressed gas be supplied to the machine at a pressure above 125 psi / 8.5 bar. Overpressure may cause mechanical failure in the machine and could be dangerous.

## Chapter 6: Controls

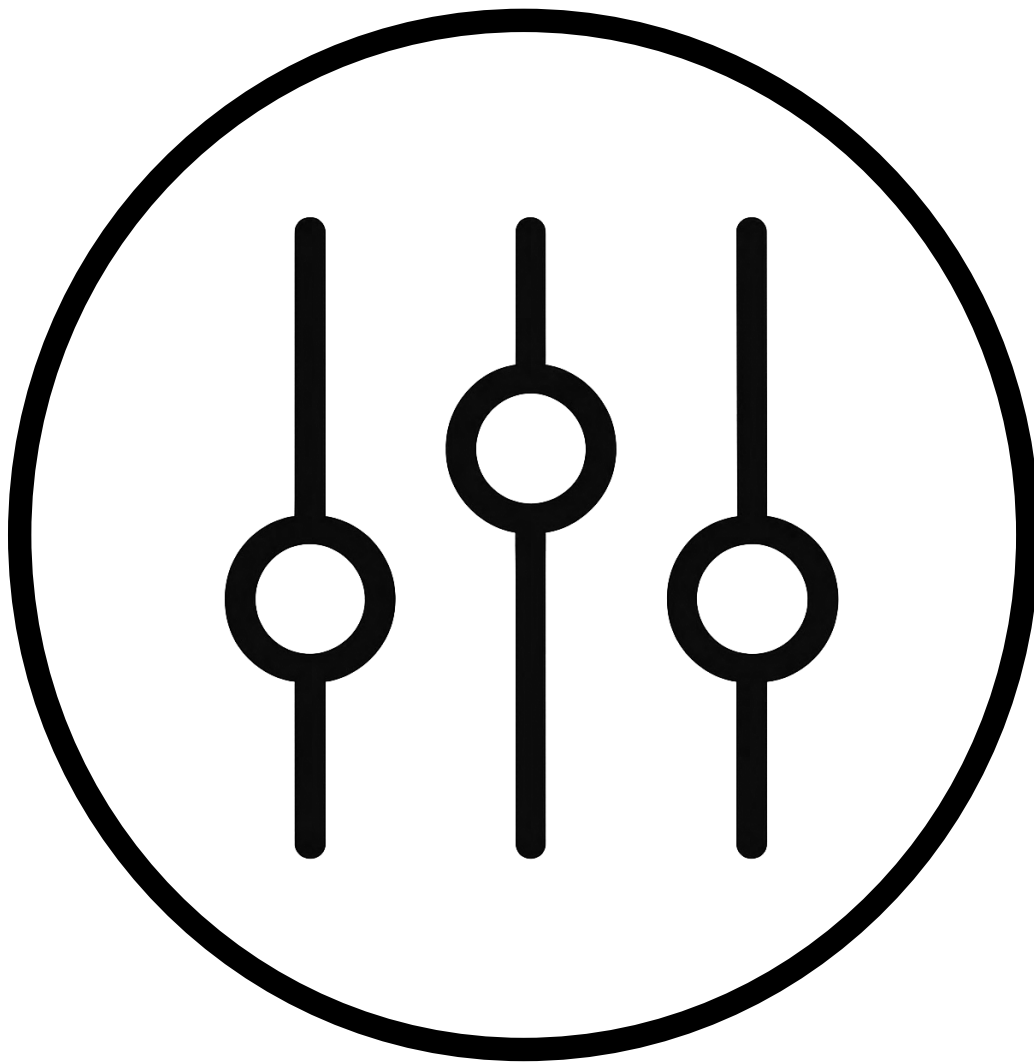

*This page has been left blank intentionally*

## Navigation

### Shortcut Menu

By pressing the external navigation button, the user can access the shortcut menu.

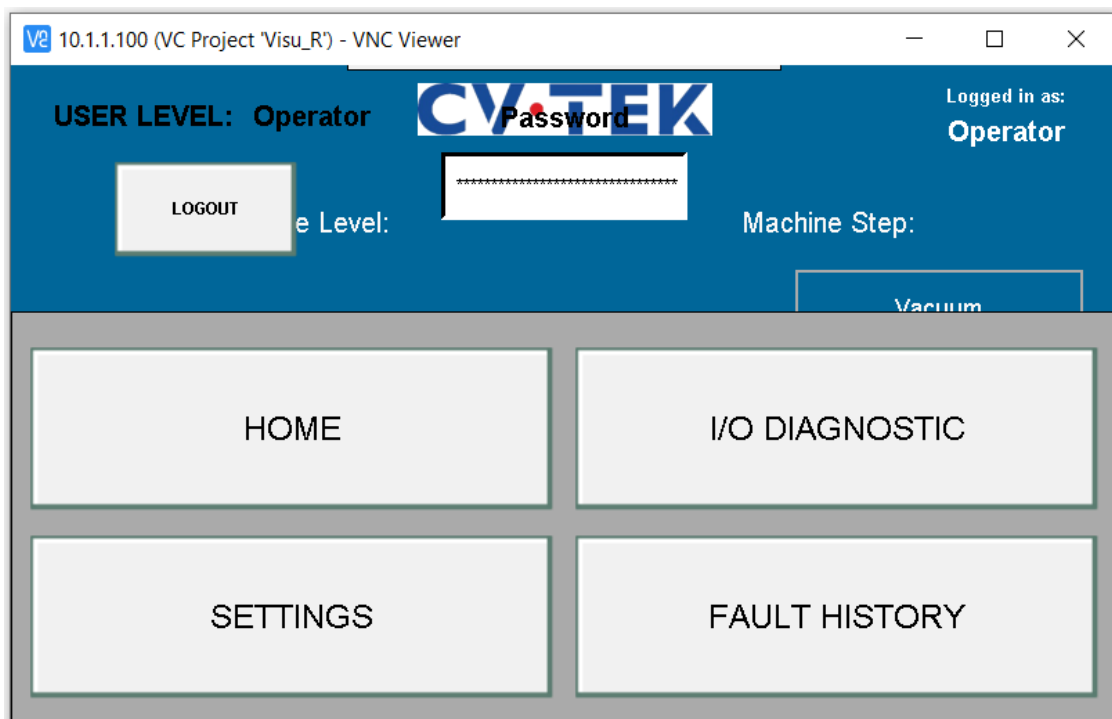
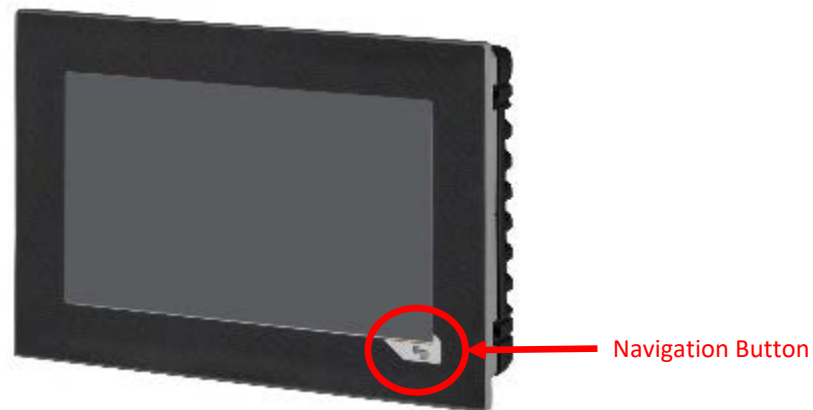

The shortcut menu has buttons to navigate to the following screens,

Home

I/O Diagnostic

Settings

Fault History

The user can also log in using the password field. The user has access to levels **Operator** and **Supervisor**. The default user level is Operator. In order to run a cycle on the machine the user needs to be logged in as an operator. The Supervisor level gives the user the ability to make modifications to program settings and force certain outputs. Pressing the password field displays the numeric pad that can be used to enter the password. In order to log in as a **Supervisor** the password is **1969**. After using the keypad to type in the password, the user needs to press the enter (check mark) button on the keypad in order for the system to acknowledge the password. To close the keypad without entering a password, the user needs to press the cancel button (x).

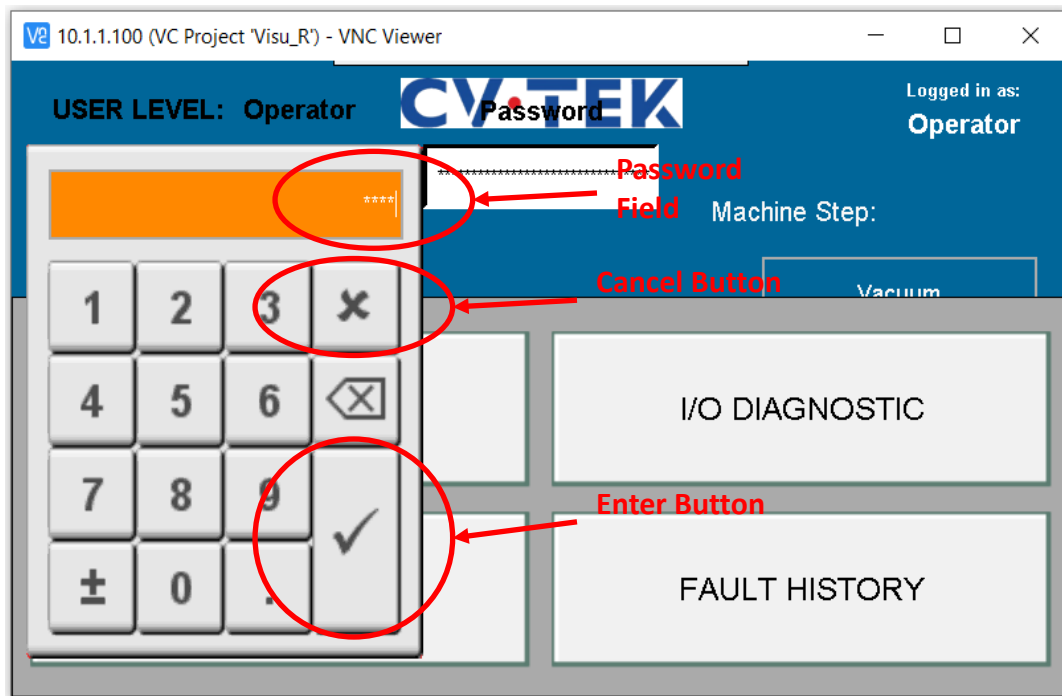

The user must logout of the Supervisor mode in order to run a cycle on the machine. This can be done by using the logout button.

In order to close the shortcut menu, tap anywhere on the transparent part of the menu.

## Home

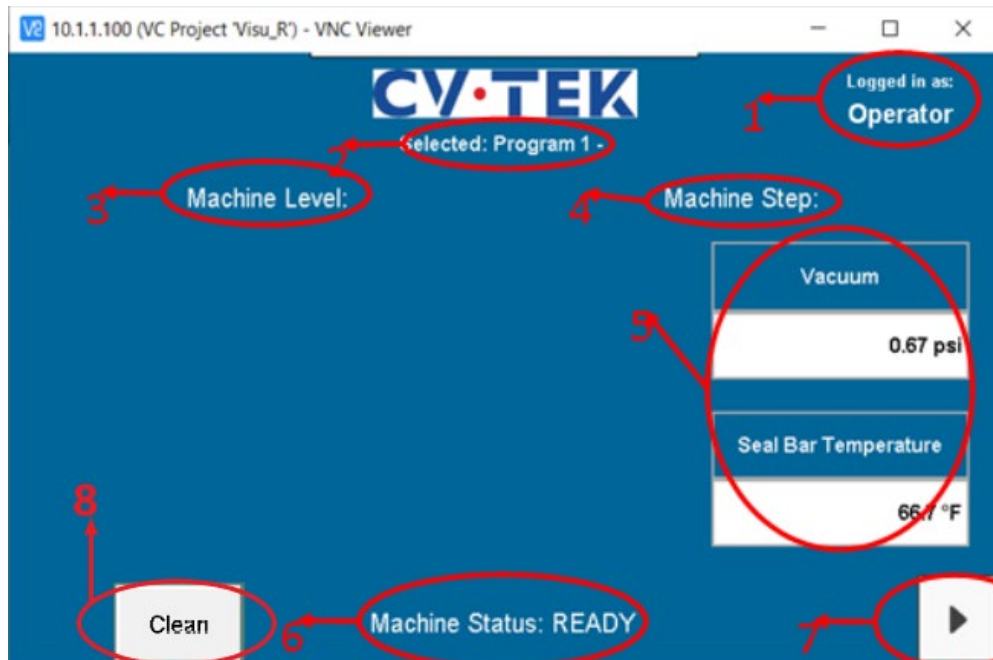

The home screen is the first screen displayed. It has the following key elements,

1. **User Level:** Shows the current credentials the user is logged in with.
2. **Program:** The current selected program is displayed in the top middle of the screen.
3. **Machine Level:** Displays the level of the machine cycle. This value can range from 1-4. This is described in more detail later in the manual.
4. **Machine Step:** Displays what stage of the cycle the machine is executing e.g. Vacuum, Soak, Gas, Pause, O2 Analyzer etc.
5. **Vacuum level and Seal Bar temperature:** Active display of current vacuum and seal bar temperature.
6. **Machine Status:** Displays the current state of the machine. This could be Idle, Ready, Run, Error or Emergency Stopped.
7. **Navigation Buttons:** Allow the user to navigate pages.
8. **Clean Button:** Enabled when machine is in IDLE or READY state. Pressing button will initiate clean cycle. Vacuum pump will run and vacuum valve will open. Manually suction hot water through snorkles being careful to not fill up vacuum bottle past the red line. If using PIAB pump, clean mode is turned off by pressing clean button again. If using motor pump, it will run for the time specified in Pump Run Time.
9. **Alarm Status:** If there is an alarm on the machine, a flashing orange triangle with an exclamation mark will appear on the top left corner of the screen. Pressing on this triangle will open up the alarm pop up as shown below,

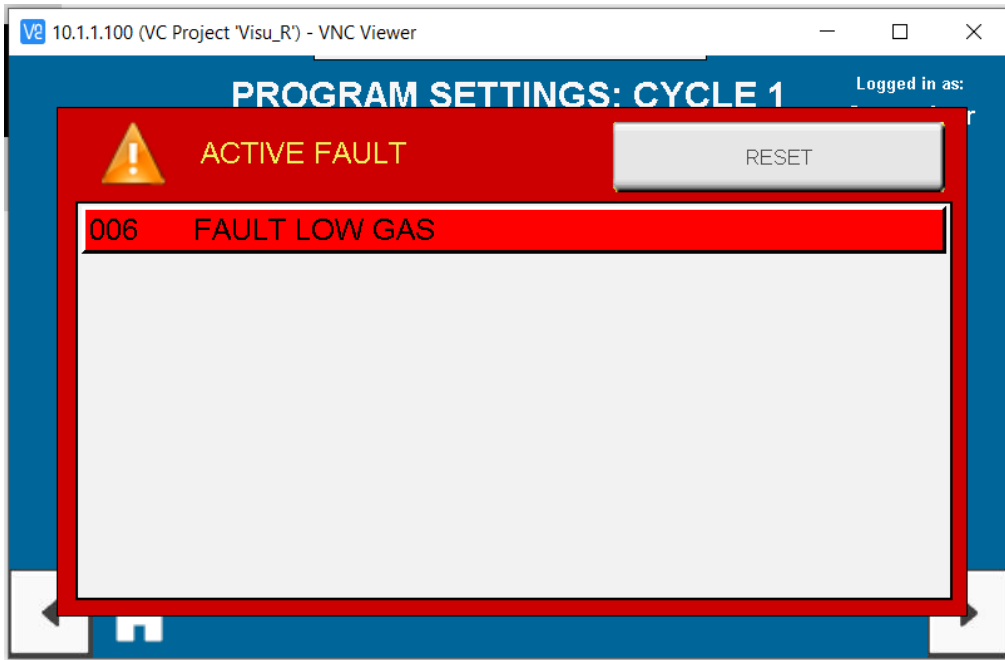

**In Order to clear any fault. Eliminate the cause of the fault first, then press the green reset button. OR the reset button activate fault pop-up. (See Pic)**



## Program Selection Screen

This screen allows the user to select the program. Depending on the machine purchased the user has the option selecting between 4 or 8 programs. The user needs to select a program for the machine to be operational.

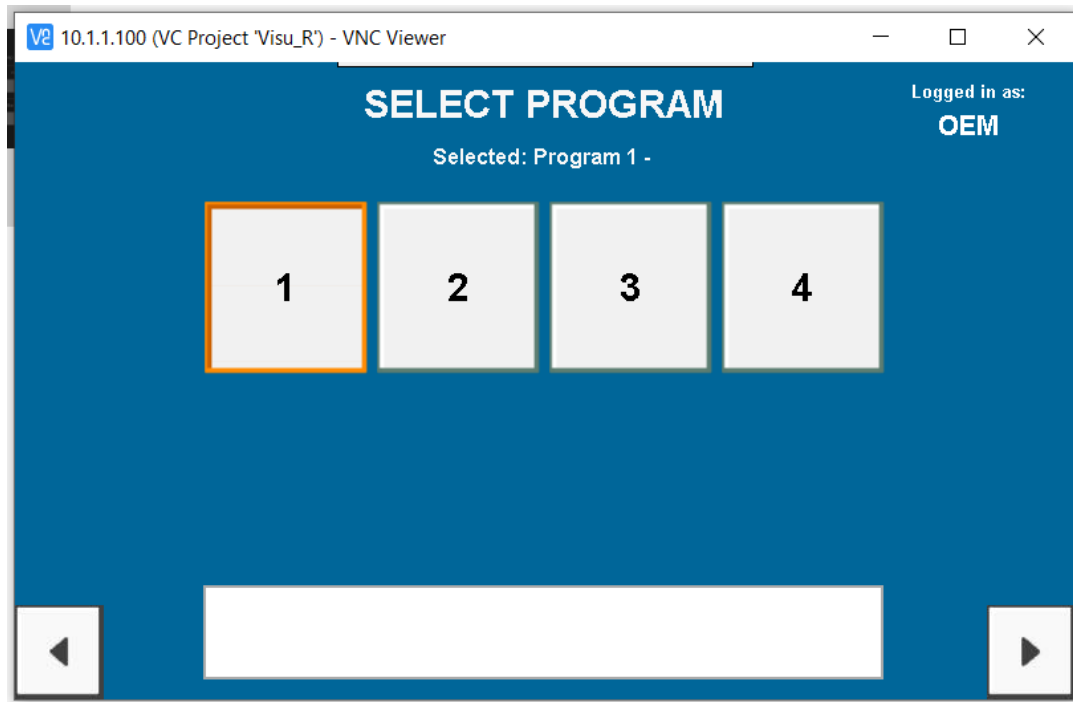

## Program Settings

The program settings screens allow the user to configure the operational parameters of the machine. The user has to be logged in as a supervisor in order to change these settings. The settings are automatically saved once they are entered into the fields specified as “current”.

In order to change the value of parameters, the user should tap on respective field that needs to be changed. The value can be typed using the keypad that appears. In order to confirm the change, the user needs to press on the enter button, however in order to discard the change the user needs to use the cancel button.

10.1.1.100 (VC Project 'Visu\_R') - VNC Viewer

# PROGRAM SETTINGS

Selected: Program 1

	CURRENT	
BAR TEMP	70.0	°F
SEAL TIME	2.0	s
HI/LO HEAD	Low	

70.0 °F

1	2	3	x
4	5	6	⌫
7	8	9	✓
±	0	.	

◀ ⏠ ▶

## Program Settings: Overall

10.1.1.100 (VC Project 'Visu\_R') - VNC Viewer

**PROGRAM SETTINGS: OVERALL**

Logged in as: **OEM**

Selected: Program 1 -

	CURRENT		SAVED	
BAR TEMP	310.0	°F	310.0	°F
SEAL TIME	2.0	s	2.0	s
HI/LO HEAD	Low		Low	

**Bar Temp:** Set the required seal bar temperature. Any change to this setting is reflected across all programs.

**Seal Time:** The duration in seconds for which the seal bar is active (extended and sealing the bag) during the seal phase of the cycle.

### Program Settings: Cycle 1, Cycle 2, Cycle 3 and Cycle 4

A machine level is defined as one set of MAP operations (Vacuum, Soak, Gas and Pause). Each program can have up to 4 levels. The values for these parameters for each level can be set on these screens. The user has to be logged in as a supervisor in order to change these settings.

10.1.1.100 (VC Project 'Visu\_R') - VNC Viewer

**PROGRAM SETTINGS: CYCLE 1** Logged in as: OEM

Selected: Program 1 -

	CURRENT		SAVED	
VACUUM	15.00	psi	15.00	psi
SOAK TIME	2.0	s	2.0	s
GAS FLUSH	3.0	s	3.0	s
PAUSE TIME	0.0	s	0.0	s

Navigation icons: Home, Previous, Next

### I/O Status

These pages depict IO statuses that allow the user to debug issues with ease.

#### I/O Status: Inputs

Statuses for all digital inputs are displayed on this screen. If the box next to a specific input is lit green, it signifies that the input is **ON**. On the other hand, a grey box signifies that the input is **OFF**.

10.1.1.100 (VC Project 'Visu\_R') - VNC Viewer

**I/O STATUS: INPUTS** Logged in as: **OEM**

Spare	<input type="checkbox"/>	Probe 1 Raised	<input checked="" type="checkbox"/>
Probe 2 Raised	<input checked="" type="checkbox"/>	RT Bag Stretch	<input type="checkbox"/>
RT Bag Stretch Up	<input type="checkbox"/>	LT Bag Stretch	<input type="checkbox"/>
LT Bag Stretch Up	<input type="checkbox"/>	3rd Bag Stretch	<input type="checkbox"/>
Low Gas PS	<input type="checkbox"/>	Vac Pump On	<input type="checkbox"/>
Spare	<input type="checkbox"/>	Spare	<input type="checkbox"/>

◀ ⏠ ▶

10.1.1.100 (VC Project 'Visu\_R') - VNC Viewer

**I/O STATUS: INPUTS** Logged in as: **Operator**

Jaw Closed PRX	<input type="checkbox"/>	E-Stop Active	<input type="checkbox"/>
Sequence Started	<input type="checkbox"/>	Right Hand	<input type="checkbox"/>
Left Hand	<input type="checkbox"/>	Spare	<input type="checkbox"/>
Spare	<input type="checkbox"/>	Spare	<input type="checkbox"/>
Spare	<input type="checkbox"/>	Spare	<input type="checkbox"/>
Spare	<input type="checkbox"/>	Spare	<input type="checkbox"/>

◀ ⏠ ▶

## I/O Status: Outputs

Statuses for all digital outputs are displayed on this screen. If the box next to a specific output is lit green, it signifies that the output is **ON**. On the other hand, a grey box signifies that the output is **OFF**.

The screenshot shows a VNC Viewer window titled "10.1.1.100 (VC Project 'Visu\_R') - VNC Viewer". The main display area has a blue background and is titled "I/O STATUS: OUTPUTS". In the top right corner, it says "Logged in as: Operator". The screen displays a two-column list of digital outputs, each with a small square status indicator to its right. The first output, "Seal Heat SSR", has a green indicator, while all other outputs have grey indicators. At the bottom of the screen, there is a navigation bar with a left arrow, a home icon, and a right arrow.

Output Name	Status
Seal Heat SSR	ON (Green)
Adv Seal Bar	OFF (Grey)
Vacuum On SOL	OFF (Grey)
Vac Pump MS	OFF (Grey)
LT Bag Stretch	OFF (Grey)
O2 Analyzer Valve	OFF (Grey)
Adv Probes SOL	OFF (Grey)
Jaw Safe Latch Supply	OFF (Grey)
Gas 1 SOL	OFF (Grey)
RT Bag Stretch	OFF (Grey)
Bag Stretch UP	OFF (Grey)
Gas 2 SOL	OFF (Grey)

The screenshot shows a VNC Viewer window titled "10.1.1.100 (VC Project 'Visu\_R') - VNC Viewer". The main display area has a blue background and is titled "I/O STATUS: OUTPUTS". In the top right corner, it says "Logged in as: Operator". The screen displays a two-column list of digital outputs, each with a small square status indicator to its right. All outputs in this view have grey indicators, signifying they are OFF. At the bottom of the screen, there is a navigation bar with a left arrow, a home icon, and a right arrow.

Output Name	Status
O2 Analyzer	OFF (Grey)
Head Status	OFF (Grey)
Right Button Light	OFF (Grey)
Spare	OFF (Grey)
Spare	OFF (Grey)
Spare	OFF (Grey)
Run Conveyor	OFF (Grey)
Left Button Light	OFF (Grey)
Okay to Start	OFF (Grey)
Spare	OFF (Grey)
Spare	OFF (Grey)
Spare	OFF (Grey)

## I/O Status: Analog

Statuses for all analog inputs and outputs are displayed on this screen.

I/O STATUS: ANALOG		Logged in as: Operator
<b>Inputs</b>		
Vacuum	7.36 psi	
Seal Bar Temperature	67.1 °F	
O2 Level	25.00 %	
<b>Outputs</b>		
Conveyor Reference	-	

## Fault History

Displays non-retentive fault history. This history is lost after a power cycle. The user can scroll through the history by using the arrow keys on the extreme right of the screen.

FAULT HISTORY		Logged in as: Operator
00	FAULT EMERGENCY STOP	
00	FAULT EMERGENCY STOP	
00	FAULT EMERGENCY STOP	
06	FAULT LOW GAS	
06	FAULT LOW GAS	
15	FAULT RIGHT BAG STRETCHER NOT UP	
14	FAULT LEFT BAG STRETCHER NOT UP	

## System Diagnostics Manager

From the fault history page, the user may access the System Diagnostics Manager (SDM). The SDM provides the user with a concise view of the PLC and IO hardware. The user shouldn't require this during regular operation. It might come in handy for advanced debugging, hence it is recommended to use this screen only with the help of technical support.

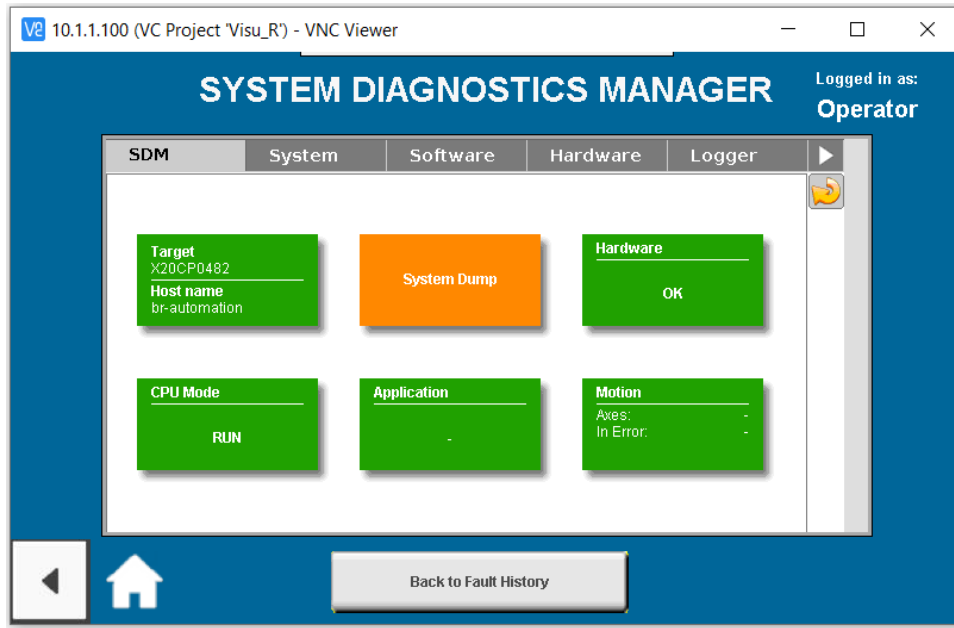

## Configuration: CMD

In order to access this screen, the user needs to be logged in as a supervisor. This screen allows the user to manually actuate the outputs in order to diagnose any issues with the machine.

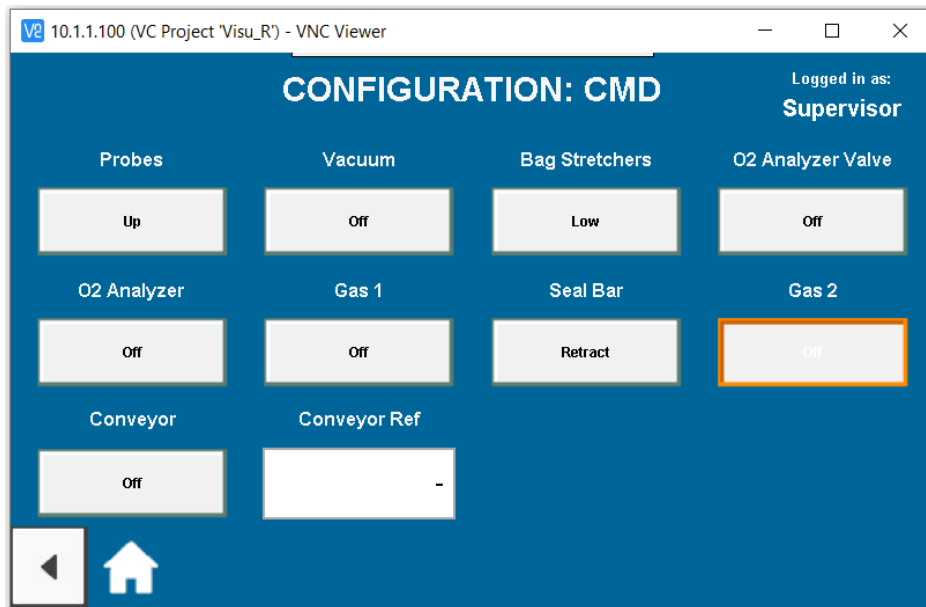

## Active Fault Popup

When there is a fault on the machine, a blinking orange triangle with an exclamation mark appears on the top left corner of the screen. Clicking on this triangle will display the alarm pop up with all active alarms.

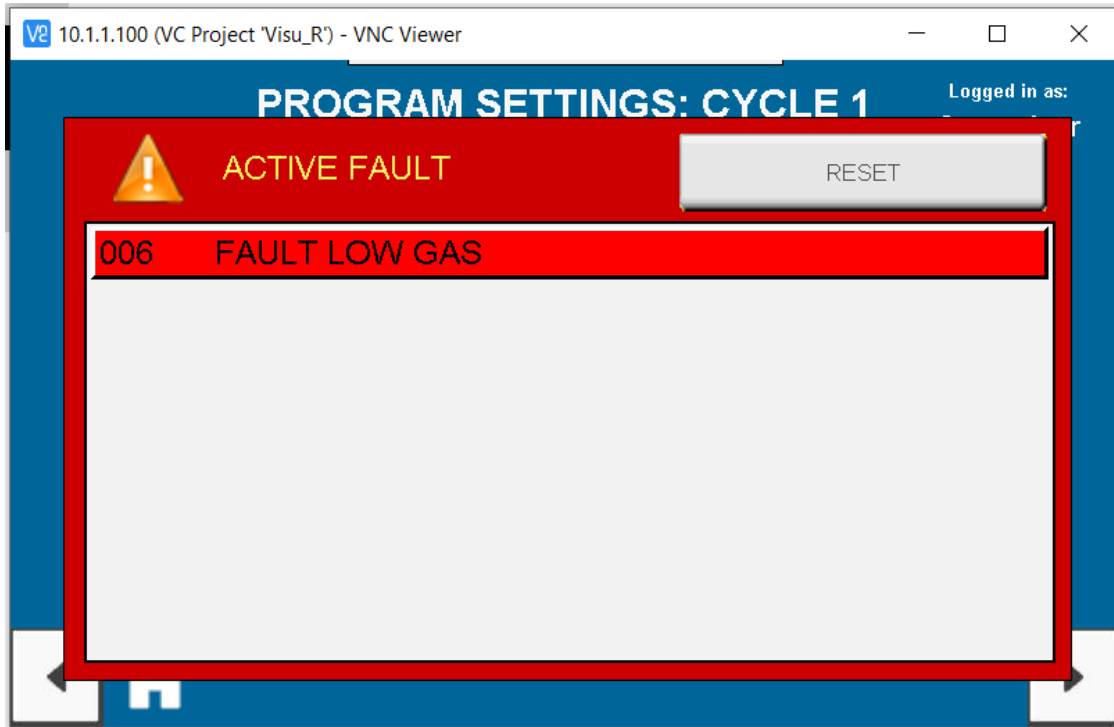

When there is an alarm, the machine goes into an error state and it ceases to function. In order to resume functionality, the root cause of the alarm needs to be diagnosed. Once the cause has been eliminated, the fault can be reset by pressing the reset button on the pop up. Some faults, causes and remedies have been detailed in the table below.

Fault	Cause	Remedy
Fault Emergency Stop	Emergency stop has been pressed	Pull out Emergency stop button and press the green reset button
Warm-Up, Below Temp	Current seal bar temperature is below set temperature.	Wait for the seal bar to heat up and hit reset button on the fault pop up to clear
Fault Temp Over Range	Seal bar is hotter than set temperature	Wait for seal bar to cool down and hit reset button on the fault pop up to clear
Fault RTD Open wire	One of the RTD wires has been disconnected.	Check RTD wiring

Fault Vacuum Pump	Vacuum pump didn't start within specified time of start command	Check vacuum pump. If pump is functional, check vacuum motor feedback wiring on motor starter
Fault Vacuum Open Wire	Fault vacuum sensor connection	Check vacuum sensor wiring
Fault Low Gas	Low gas pressure on the machine	Check if gas has been connected to the machine, if connected make sure gas pressure is above 40 psi
Probe ½ Not Down	Probes haven't been pushed down during cycle	Make sure probes are physically down. If they are check probe tower sensors for defects. If either probe isn't physically down check probe solenoid valve and tubing. Check air pressure.
Probe ½ Not Up	Probes haven't been retracted after cycle in order to fire seal bar	Make sure probes are physically up. If they are check probe tower sensors for defects. If either probe isn't physically up check probe solenoid valve and tubing. Check air pressure.
Fault Jaw not open	Jaw hasn't opened after cycle has finished	Check jaw closed sensor and check jaw close solenoid.
Fault Jaw not closed	Jaw opened before finish of cycle	Check jaw sensor and jaw close solenoid. It may also be a problem with the safety PLC at which point call tech support.
Fault Left/Right bag stretcher not up	Bag stretchers not up before seal bar was fired	Check bag stretcher cylinders, air pressure and bag stretcher up sensors for issues
Fault Error IO Check...	Issue with the specified IO card	Call technical support for replacement IO card

## Operation

1. Connect 480V 3 Phase power, air and gas to the machine.
2. Turn power ON to the machine using the disconnect on the back of the machine.
3. Once the machine is powered and the screen is on displaying the home screen, make sure a program is selected by navigating to the program selection screen using the right arrow button on the bottom right of the home screen.
4. To make sure the right parameters are saved in the selected program, navigate to the program settings page by using the bottom right arrow button. If the desired settings are not in the program, the user will require supervisor level credentials in order to make modifications.
5. Once the desired parameters have been keyed, navigate back to the home screen. This can be done using the left arrow button on the left bottom corner of the screen or by using the shortcut menu.
6. On the home screen, make the user is logged in as an Operator. If not, then tap on the “Logged in as” display on the home screen to logout. The user may also logout by using the logout button on the shortcut menu.
7. If the machine is ready to RUN, then the machine status on the home screen will display “Machine Status: Ready”.
8. If the machine is not ready because it is not up to temperature, a progress bar will be displayed on the screen notifying the user that the seal bar is getting up to temperature.
9. Once the machine is ready to run, load the bag using the bag stretchers (optional). The bag stretchers can be actuated by pressing them.
10. Once the machine is ready, press the two buttons on either side of the display box to initiate the cycle. The cycle starts by the jaw closing. The user needs to press the buttons until the jaw is closed all the way. Failure to do so will result in the jaw opening again and the cycle will not begin. The user should press the buttons until the touch buttons illuminate GREEN. Once they are illuminated it is safe for the user to remove his/her hands from the buttons.
11. Once the jaw is completely closed the cycle will continue as configured in the selected program.
12. After completion of the cycle, the jaw will automatically open and the sealed bag should be removed by the user.
13. The process can be repeated for multiple bags.

**Chapter 7: Preventative Maintenance**

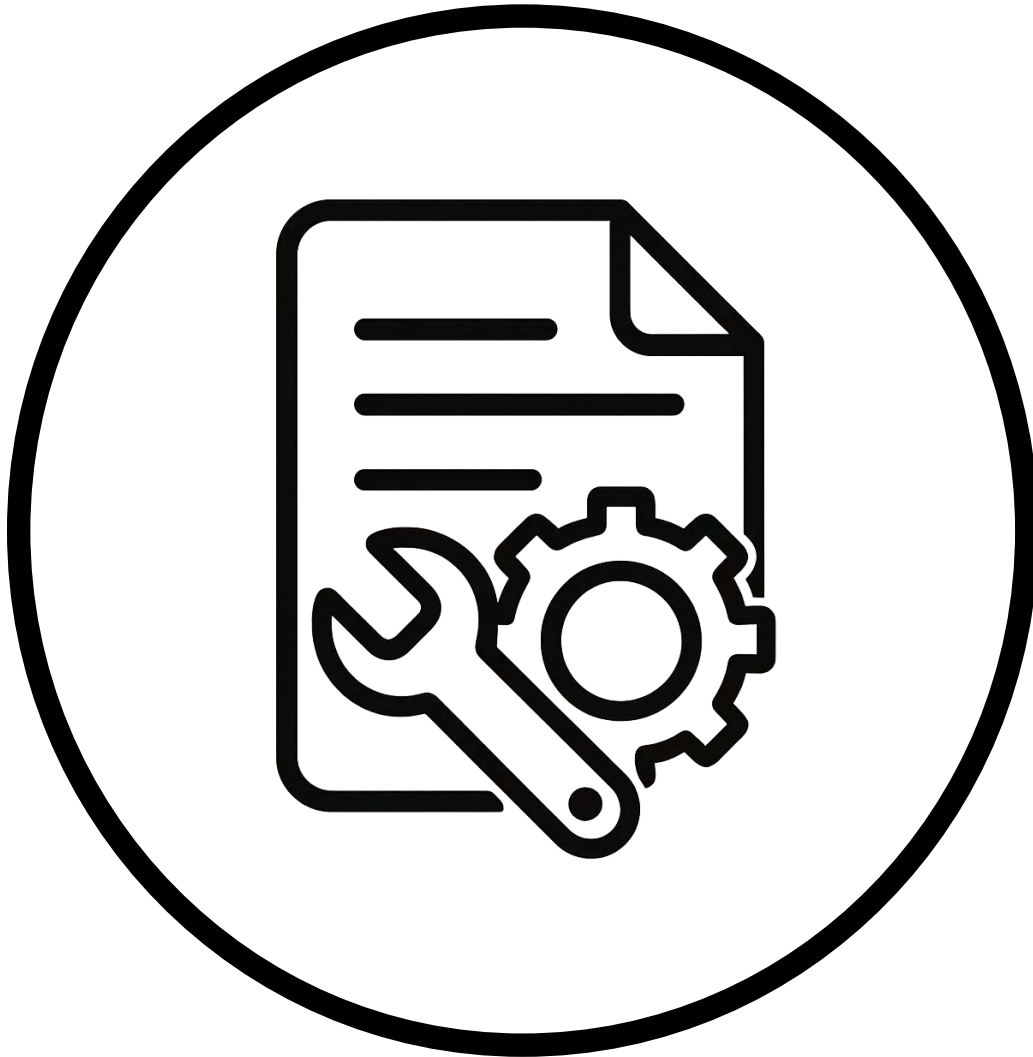

Different machine models or options, as well as various product applications, have different preventative maintenance requirements.

## 7.1. DAILY CHECKS

- Before operating, drain water from the air compressor tank and supply line to machine. Drain water filter on machines with manual drain. Is supply air pressure above 100 psi / 7 bar?
- Is gas supply adequate?
- Are vacuum line filters clean?
- Does cabinet cooling fan operate whenever pump is running?
- Is heat sealer bar clean?
- Is the vacuum/gas cycle and heat-seal operational?
- Is the conveyor at the correct height and parallel to the machine head?
- Are there any sharp points on the machine around the heat sealer area that could damage the vacuum bags? Is the bag forming mandrel (when used) also OK?

## 7.2. DAILY CLEANUP

- See CLEANING section of this manual.
- Clean the vacuum filter as necessary.
- Remove the vacuum cover plate. Clean it, and the probe carefully (a tooth brush is recommended). **Be careful not to scratch or dent the mating surfaces of the probe and cover plate, or vacuum leakage can occur.**
- Clean the heat sealer bar as needed. **Do not scrape or use abrasives, as this can damage the Teflon coating and change the bar's heat-sealing characteristics.**
- Clean the surface of the silicone rubber strips which are contacted by the heat sealer bar (on the clamping jaw) as needed. These strips should not be removed unless they are to be replaced.
- Flush the vacuum pump(s) with water as needed to avoid later problems with sticking pump vanes. With the pump running, dip the pump's vacuum inlet tube into a maximum quantity of 2-3 tablespoons of water. Do not exceed this amount or the pump may be damaged. The water will flush the pump and be expelled into the exhaust muffler bottle. This process should be repeated a few times, and then the bottle should be emptied. **Allow the pump to run for 15 minutes to dry it internally.**
- Turn off the main electrical disconnect switch on the door of the electrical cabinet.
- Shut off or disconnect the air supply to the machine.
- Shut off the gas supply valve. It may also be advisable to remove the handle on the gas supply regulator in case someone accidentally turns it to a dangerously high pressure setting.

### 7.3. WEEKLY CHECKS

- Clean out any material that may have accumulated in the water filter section of the air regulator assembly.
- Refill the lubricator jar in the air regulator assembly with mineral oil or “white” oil. **Do not use any other oil, or damage may occur within the machine.** Ensure that the lubricator is releasing approximately one drop for every 1-3 packages at the normal packaging line speed. If not, adjust the small needle valve screw which is located in a recessed well next to the clear plastic dome where you can observe the oil drip rate.
- Consult your vacuum pump manual for the proper maintenance as well as the recommend service schedule in the appropriate vacuum pump manual.
- For all water-ring pumps, check the in-line strainer on the water supply manifold for accumulated debris.

### 7.4. AS NEEDED

- All rotating and sliding surfaces on the head must be lubricated periodically as described in the MAINTENANCE section. Frequency of lubrication will be determined by operating conditions such as line speed, dusty conditions, frequent washing of the machine, etc.

*This page has been left blank intentionally*

**Chapter 8: Maintenance and Repair**

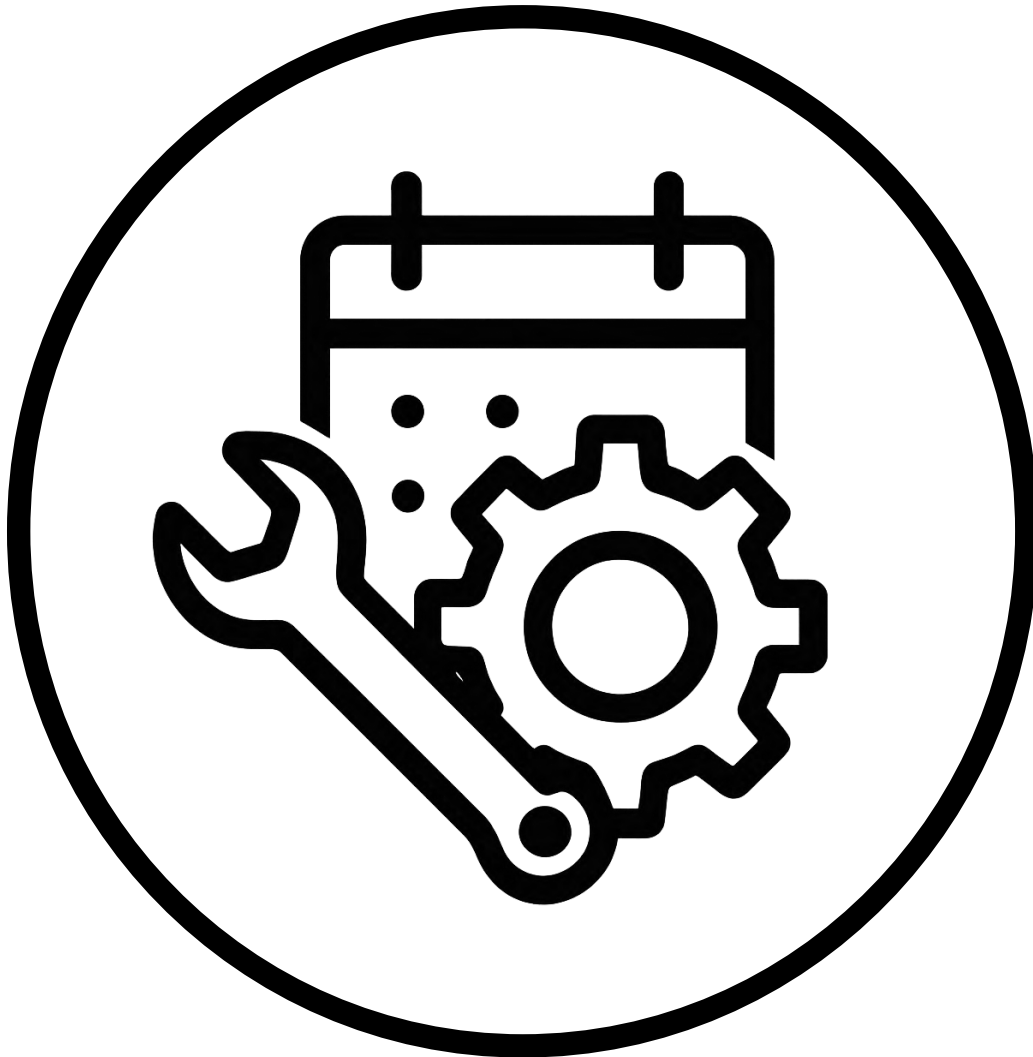

Most components of the machine are very straightforward to work on. The following sections describe only those operations where the best working method may not be as obvious.

## **8.1. MACHINE COMPONENTS IDENTIFICATION**

### **10 cfm Vacuum Pump Service**

Most repairs or cleanup of the pumps can be made in place, in the machine. Tear-down is done as follows:

1. Remove the exhaust muffler bottle. If the pump exhausts through the side of the pylon, remove the nylon elbow. If the controls air exhausts into the pump exhaust line, disconnect this line.
2. Disconnect the inlet tube at the fitting on the pump head.
3. Remove the six bolts around the top of the pump head.
4. Lift the pump head off the pump body, being careful not to scratch the surfaces where the pump head and body mate.
5. Examine the four carbon vanes for serious chipping. They should slide freely in their slots. They must be inserted so that the bevel on their outer edges matches with the angle of the walls of the pump “barrel” or “cylinder.”
6. Carefully replace the pump cylinder head and retighten the six bolts in an alternating pattern (1 and 4, 2 and 5, 3 and 6). Replace inlet and exhaust fittings and lines.

### **21 cfm Vacuum Pump Service**

1. Disconnect power to the machine.
2. Remove fan by gently levering it off with a flat bladed tool.
3. Remove eight (8) hex head cap screws holding end plate on unit.
4. Remove four (4) Phillips screws that hold end cap to end plate.
5. Using a puller tool remove the end plate.
6. Remove old vanes and check for foreign particles in pump chamber. Ensure that the four vane slots in the rotor are completely clean (clean with solvent as needed).
7. Install new vanes with beveled edges to match angle of pump body wall.

8. Install end plate (use a rawhide mallet or leaded rubber mallet to tap end plate down). There are two guide pins to line up on.
9. Install the eight (8) hex head cap screws to hold the end plate in place.
10. Using a  $\frac{3}{4}$ " deep well socket, placed over end of shaft, drive or set bearing fully to provide clearance for rotor to turn freely.
11. Install end cap with four (4) Phillips screws (making sure to have good seal).
12. Replace fan on shaft. Make sure fan does not hit Phillips screws of end cap.
13. Install fan guard with four (4) round head screws.

### **28/35 cfm Vacuum Pump Service**

See Vacuum Pump Manual

### **Water-Ring Vacuum Pump Service (All Models)**

See Vacuum Pump Manual and Drawings

### **Electric Vacuum Pump Removal**

1. Mark III pumps are removed by unbolting the pump mount screws from under the machine, with the exception of the Gast 35 cfm/50 cfh model.
2. Gast 35 cfm/50 cfh pumps have rubber mounting "feet" located at two points under the front of the pump/motor mount and at three points under the rear of the mount.
3. From above, remove the screws holding the mount down to the rubber feet at both points under the front, but only at the center point, in the back. You can then slide the pump/motor out of the cabinet.

### **Thermocouple Replacement (Hot-bar Sealers Only)**

Thermocouples are replaced by first disconnecting the two electrical leads inside the button box compartment, releasing the compression nut on the fitting at the bottom of the button box, and pulling the lead, in their flexible sheath, out of the button box. The sheet metal pan under the heat seal bar should be removed exposing the entry of the thermocouple sensor into the back of the heat seal bar. Remove the outer compression nut, and withdraw the thermocouple sensor. When installing the replacement thermocouple, certain precautions should be observed:

1. The thermocouple leads are vulnerable to kinking, so tight bends should be avoided.
2. When installing the sensor into the back of the heat seal bar, ensure that the small ferrule on the sensor is not lost. The tip of the sensor must also be fully “bottomed out” into the full depth of the well in the bar.
3. Note that the two leads are polar (+ and -) and must be connected to the temperature controller as shown in the circuit diagram.

### **Head Bearings Lubrication**

Head bearings should be periodically lubricated at all rotating pivot points, and sliding surfaces. A heavy, water-proof grease is recommended – comparable to the food-grade lubricants provided with later model machines.

1. Pivot points can be opened up by first removing the shaft retainer, near the right-hand end of the main pivot shaft (to which the operating handle is attached). This allows the shaft to slide sideways far enough to clean and lubricate the shaft bearings, link pivot pins and clamping bar pivot pins.

When replacing the shaft retainer, be sure that the excess play is removed by pushing the shaft to the left before tightening the retainer.

## Flow Controls (Air Cylinders)

Pneumatic flow controls are provided on most air cylinders on the machine to regulate their speed. This serves two functions:

1. Both ends of the heat seal bar should extend and retract at the same speed, to avoid misaligning the bar.
2. Extension and retraction speed for all cylinders, should be controlled to avoid hammering at the end of the stroke.

The flow control meters the air being pushed out ahead of the moving piston in the cylinders, thereby controlling the piston's speed. The flow control mounted on the end of the cylinder toward which the piston is traveling will control the stroke in that direction only. Cylinders without flow controls have internal bumpers to cushion their stroke.

## Vacuum and Air Pressure Fittings

Most plastic vacuum tubes use white nylon compression fittings. The compression nut for these fittings can be adequately tightened with finger pressure **and tools should never be used.**

Air (pneumatic) tubes use "push-lock" fittings:

1. To install a tube into a fitting, simply push the tube into the fitting until it bottoms out.
2. To remove a tube, push down on the locking ring at the top of the fitting, and pull the tube out. To release the ring it is important to push it down evenly, from all sides.

## Silicone Rubber Parts Service

The silicone rubber parts are very durable, and rarely need replacement. When necessary, the following tips apply:

1. Heat Seal Back-up Strip (Hot Bar)  
This item can be removed by lifting the old strip out of the machined groove in the clamping jaw. Adhesives are not used for installation, as the rubber makes a tight fit in the groove. After installing the new rubber strip(s), adjustments may be necessary to tune for the most uniform heat seal, before the ends of the strip are trimmed flush with the clamping jaw. Make a few test seals in the Corr-vac® bags, and examine them carefully for signs of any low pressure areas in the heat seal.

These can be remedied by slightly bunching up (or compressing) the rubber strip as it is installed in the machined metal groove, in those low pressure areas.

Alternatively, the rubber can be slightly stretched in high pressure areas. This tuning process will result in the most uniform heat seals possible.

## 2. Heat Seal Back-up Strip (Impulse)

Once the ends of the strip become excessively scorched from heat, the strip can be turned over and reused for one additional operating period. Replacement is as follows:

- The groove in the jaw must first be clean and dry.
- Push one end of the rubber strip into the narrow portion of the groove, so that it is flush with the point where the groove widens out (near each end). Then push the remainder of the strip into the groove, working progressively across the jaw from the starting point. Avoid either stretching or compressing the rubber while you install it, or this may create an uneven thickness in the strip. Cut off the other end of the strip, so that it is flush with its end of the narrow groove.

The Bag Clamping Strip can also be removed by pulling it out of its machined groove. The replacement should be thoroughly lubricated with soap water to ensure that it fully “bottoms out” in the groove. Start by lining up the die-cut opening in the rubber to exactly match the vacuum probe assembly. Slight stretching or bunching of the rubber may be necessary to ensure a perfect fit. Then push the rest of the strip fully into the groove.

To replace the rear probe seal, the metal seal retainer must first be removed. When installing the new seals, adjust the two mounting screws until the seal retainer is just snug on top of the seal. Excessive tightening of the screws will cause the seal to bulge outward and interfere with the vacuum probe and clamping jaw closure.

## **Heat Sealer Bar Teflon® Tape Service (Hot Bar)**

Depending on the type of vacuum bag being used, some machines are equipped with an adhesive-backed strip of Teflon coated glass fiber tape, over the working face of the heat sealer bar. As the tape becomes worn, it will periodically have to be replaced.

1. Turn the SUPERVISOR'S KEY to the PROGRAMMING POSITION. Select any program number, then move through the DISPLAY screens until you find:

MAINTENANCE  
SEAL BAR IN

2. Press the EDIT BUTTON to extend the sealer bar.
3. Peel the old tape off, and clean the old adhesive off the bar with a plastic pot scrubber and solvent. Dry thoroughly before mounting the new tape.

4. Avoid getting any grease or oil from your hands on the bar.
5. The tape should be lightly tacked to the working face of the bar at one end, with a one-inch overhang. Leave 5/8" of tape projecting below the bottom edge of the seal bar (when finished, the tape will be just short of the screw heads under the bar).
6. Work across the face of the bar, lightly tacking the tape down without wrinkles. With a smooth object, firmly tack the tape to the face of the bar, taking care to push it into the recess below the raised edge on the face of the bar.
7. Trim the tape ends flush with the ends of the bar.
8. Wrap and secure the tape back over the top and bottom of the bar, without wrinkles. Firmly tack down with a smooth object.
9. Press the EDIT BUTTON to retract the heat sealer bar, and then turn the SUPERVISOR'S KEY back to the RUN POSITION.

### **Impulse Heat Sealer Service**

The impulse sealer heats by pulsing current through a sealer band (made of a resistance heating alloy), for a controlled period of time. The heat sealer bar remains engaged for an additional controlled period of time, during which the bag seal cools to a stable condition. The sealer bar then retracts, releasing the bags.

The heat sealer bar is treated with a black anodized coating, to electrically insulate it from the current passing through the sealer band. Avoid scratching the coating surface, as electrical shorting and/or corrosion can eventually occur.

Additional insulation is provided by inserts of phenolic plastic, at each end of the sealer bar.

The surface directly behind the sealer band is also protected with a renewable layer of special Kapton® tape. It must occasionally be replaced, as needed, to avoid electrical shorting.

There are two styles of impulse sealer bands.

1. For bands with metal eyelets installed at each end, first remove the terminal screw from each end of the sealer bar. Install the new band with the colored dot facing outward (away from the sealer bar), and reinstall the two terminal screws.
2. For bands without eyelets, remove the hold-down screws, and the hold-down covers at each end of the sealer bar. Insert the short tab of the new band into the fitting at each end, with the hold-down screws finger tight. Then tighten both screws.

Heat sealer tape must be periodically replaced, as needed. It should be installed as shown below, making sure that it does not cover the cooling air openings on the underside of the bar. Access to the bar can be improved, as follows:

1. Turn the SUPERVISOR'S KEY to the PROGRAMMING POSITION. Select any program number, then move through the DISPLAY screens until you find:

**MAINTENANCE  
SEAL BAR IN**

Press the SET BUTTON to extend the sealer bar.

2. To retract the heat sealer bar, press the SET BUTTON, then turn the SUPERVISOR'S KEY back to the RUN POSITION.

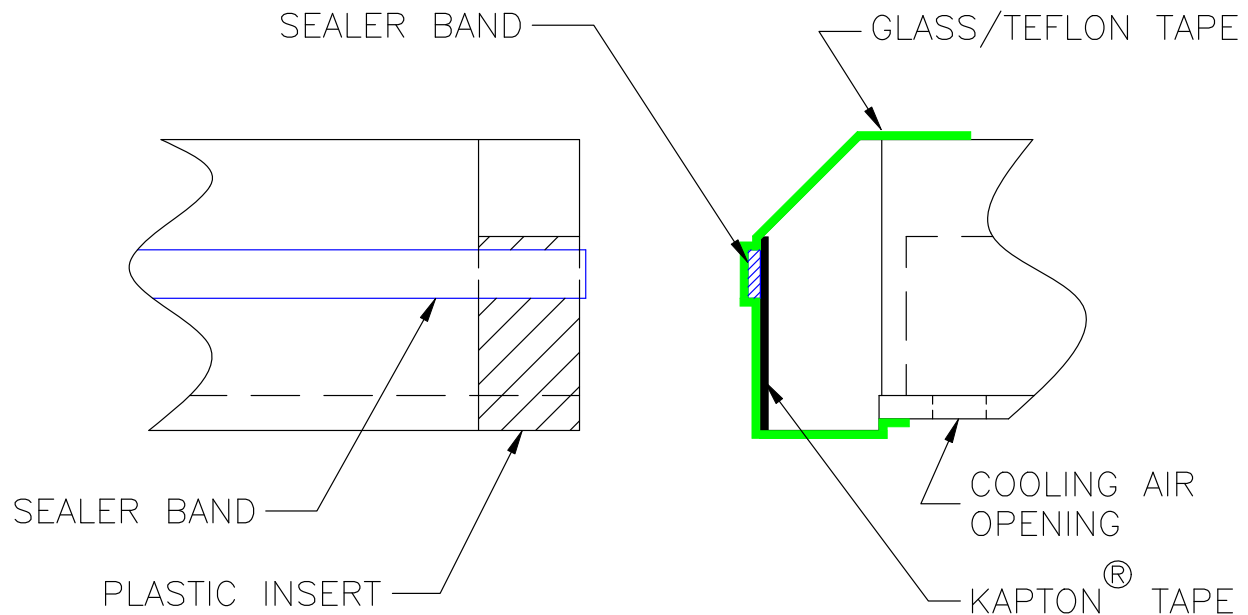

### **Automatic Jaw Opener Adjustment**

Adjustments to the jaw opening action can be made at the small air flow control, located on the auto jaw opener cylinder.

1. If the machine jaw doesn't fully open, slightly increase air flow at the flow control.
2. If the jaw opens too fast (and bounces partially shut), slightly reduce air flow at the flow control.

*This page has been left blank intentionally*

## Chapter 9: Electrical Schematics and Bulletins

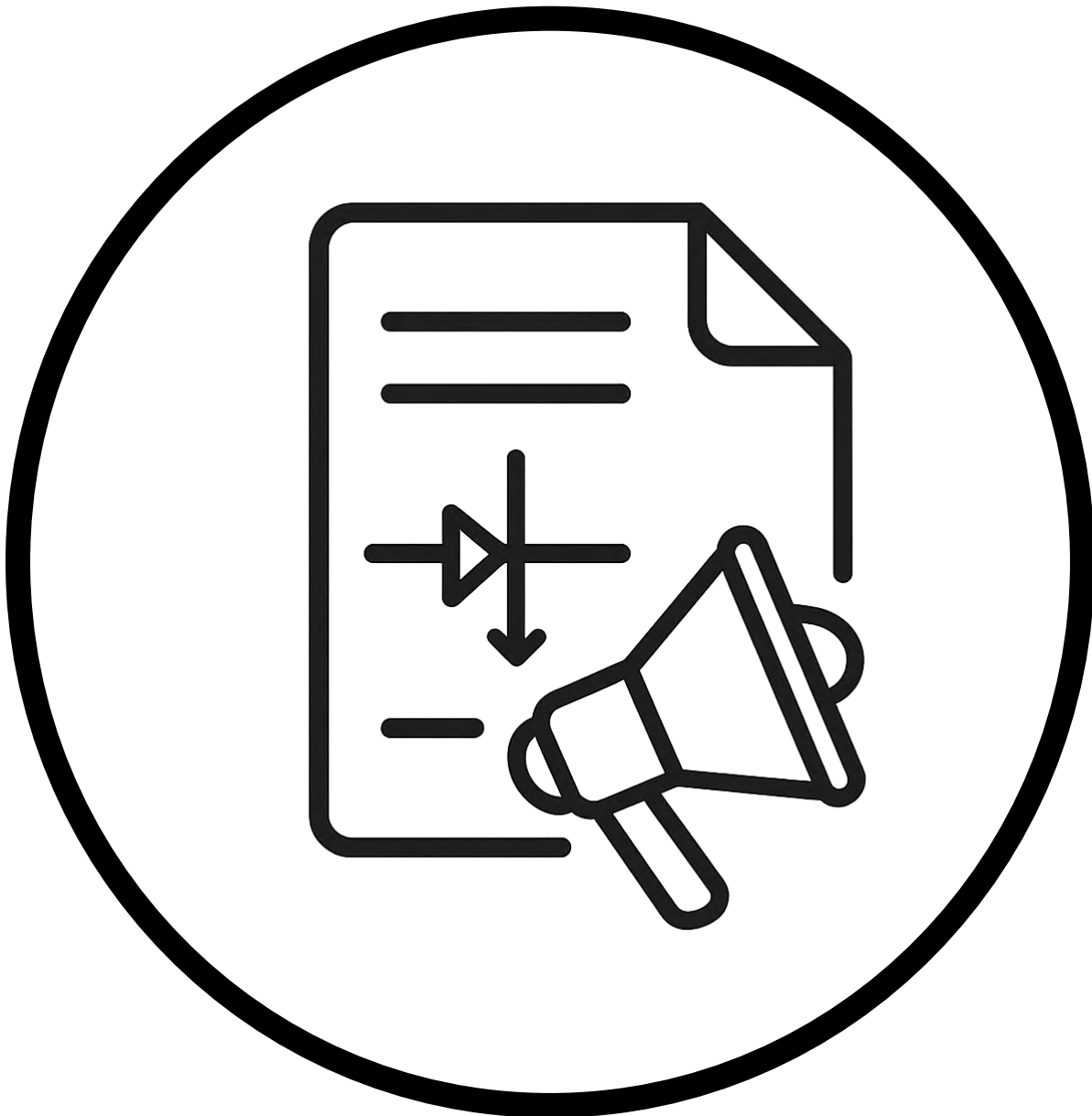



REVISIONS		DESCRIPTION	DATE	APPROVED
ECO	REV			

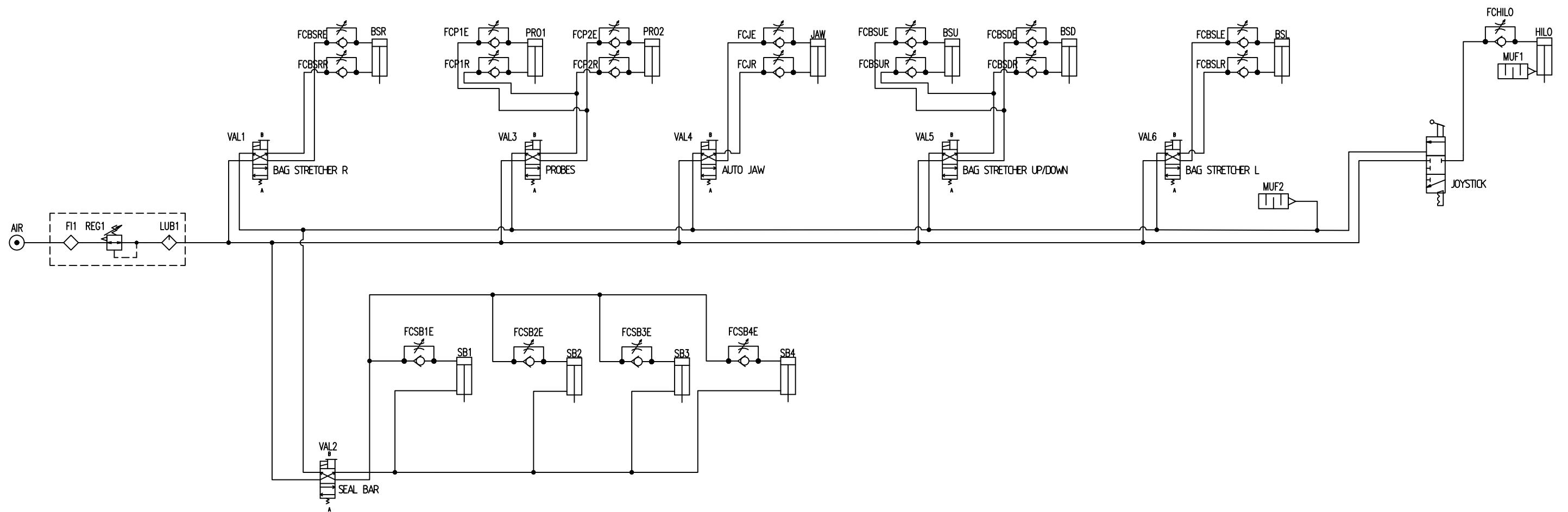
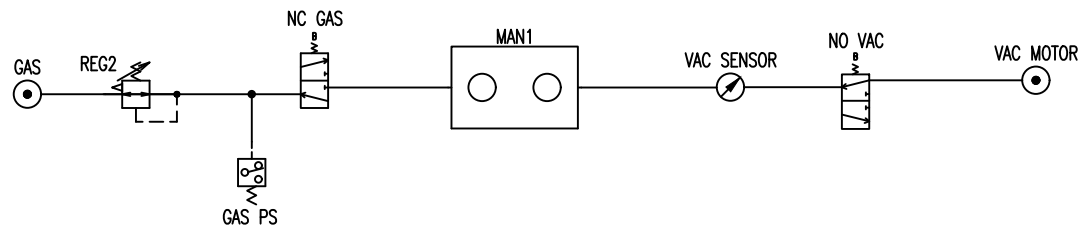

# CV-TEK

<p>THIS DRAWING IS THE PROPERTY OF CV TEK, INC. AND IS TO BE CONSIDERED CONFIDENTIAL. USE OR REPRODUCTION WITHOUT THE EXPRESS PERMISSION OF THE COMPANY IS STRICTLY PROHIBITED.</p> <p>TOLERANCES: UNLESS OTHERWISE STATED:          FRACTIONAL = ±.015          .XX = ±.015          .XXX = ±.005          DRILLED HOLE: STANDARD S.A.E.</p>	APPROVED MFG: DRAWN BY: R. HILL	APPROVED ENG:  
	TITLE: MAP-VAC PNEUMATIC DIAGRAM	
	DWG NO.: -	REV: -

CUSTOMER SUPPLIED  
480 OR 208 TO 240 VAC

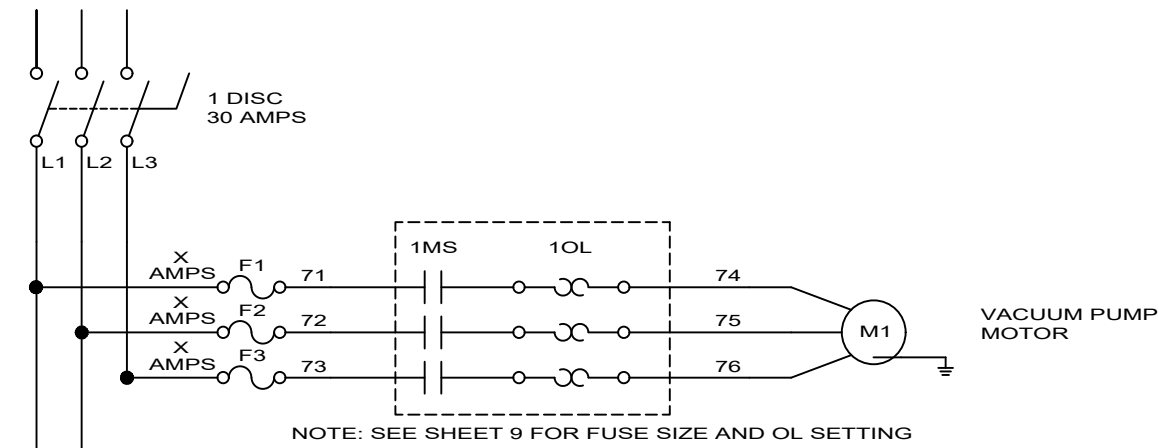

NOTE: SEE SHEET 9 FOR FUSE SIZE AND OL SETTING



**TRANSFORMER**

NOTE: SEE DETAILS AT RIGHT FOR HOOKUP

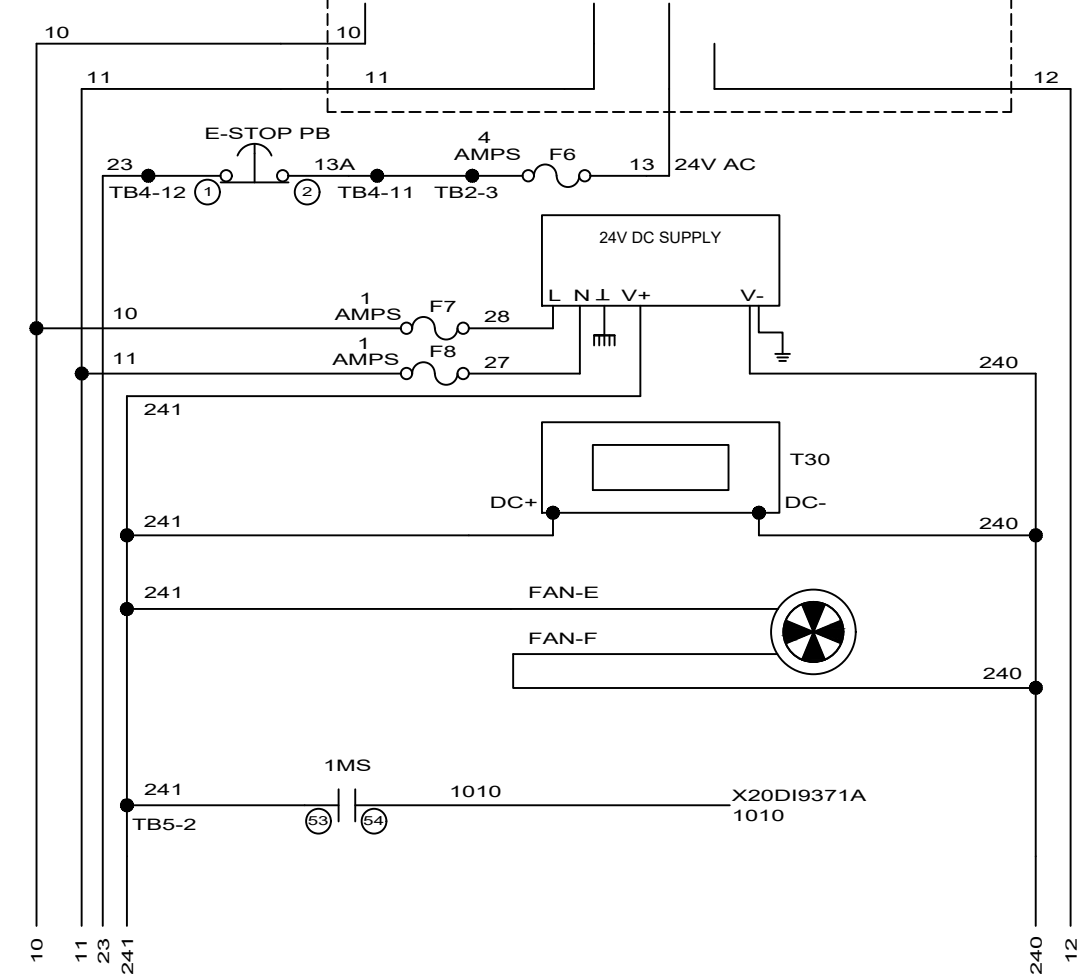

BR 6PPT30 DISPLAY  
(FRONT J-BOX)  
IP = 10.1.1.50  
SEE SHEET SIX (6)

ENCLOSURE  
COOLING  
FAN  
NOT USED WITH WATER RING PUMP

WATER VALVE  
SOLENOID  
USED WITH WATER RING PUMP

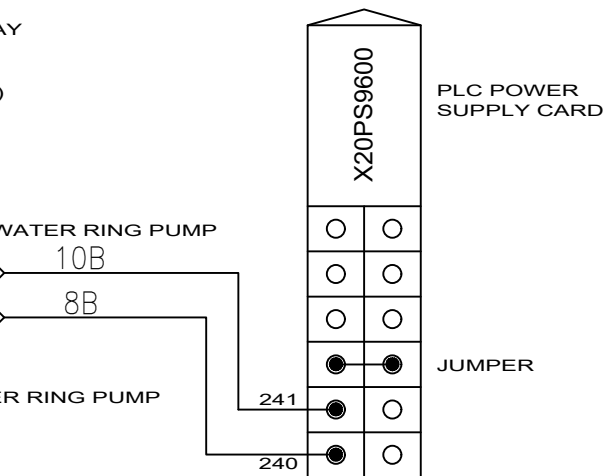

REVISIONS				
ECO	REV	DESCRIPTION	DATE	APPROVED
	A	UPDATES PER DAVE	2/26/2020	
	B	UPDATES PER DAVE	2/27/2020	
	C	CORRECTED WATER VALVE SOLENOID LINE & TRANSFORMER	10/19/2020	

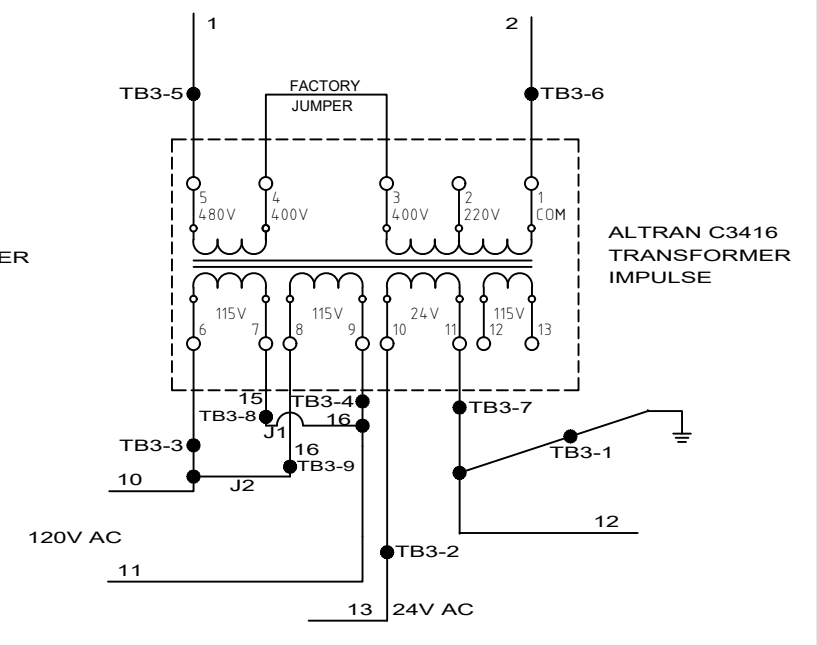
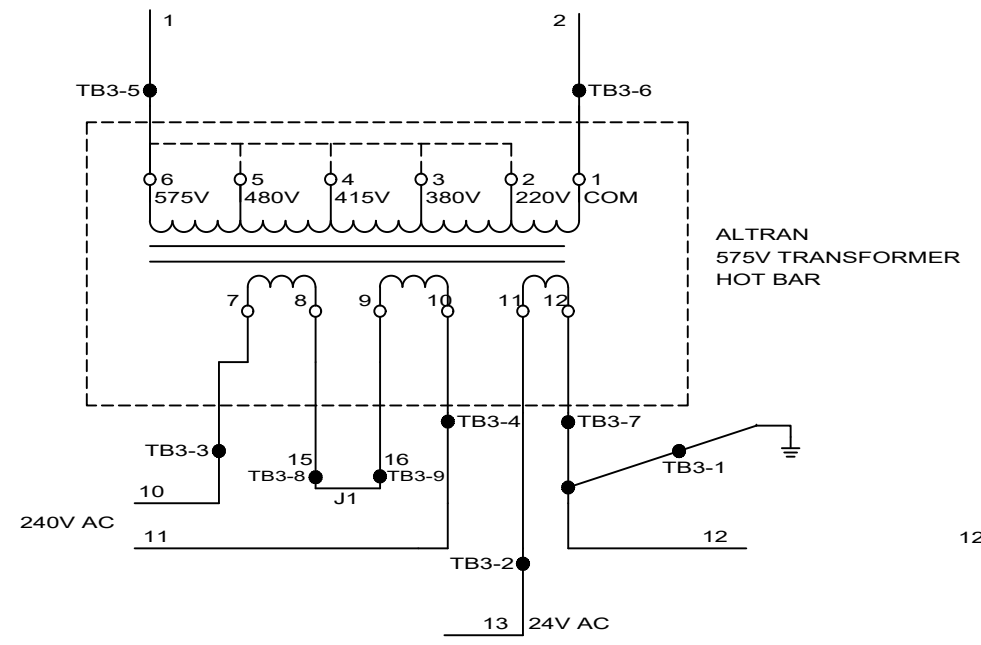
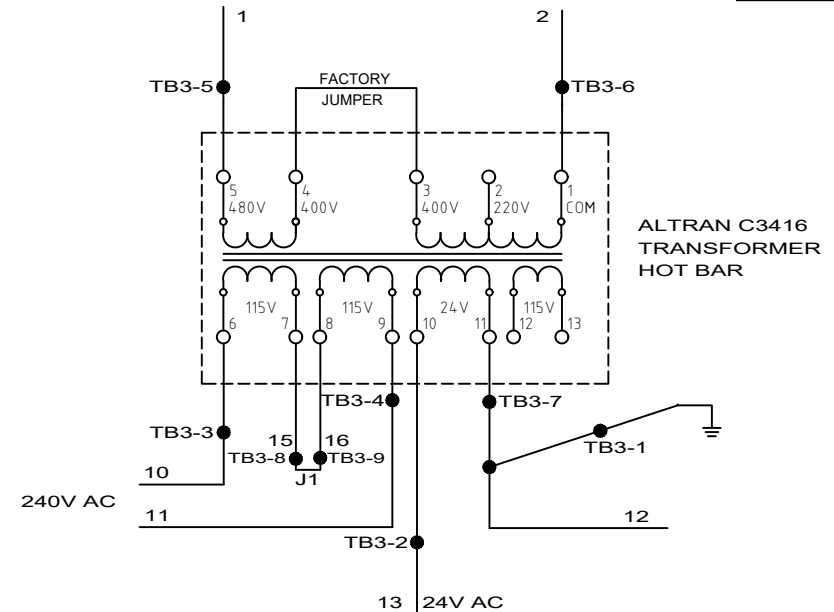

**CV-TEK**

THIS DRAWING IS THE PROPERTY OF CV TEK, INC. AND IS TO BE CONSIDERED CONFIDENTIAL. USE OR REPRODUCTION WITHOUT THE EXPRESS PERMISSION OF THE COMPANY IS STRICTLY PROHIBITED.		APPROVED MFG:	APPROVED ENG:
TOLERANCES: UNLESS OTHERWISE STATED: FRACTIONAL = ±.015 .XX = ±.015 XXX = ±.005 DRILLED HOLE: STANDARD S.A.E.		DRAWN BY: R. HILL	
LEGEND 10 & 11 = 240 OR 120 VAC 23 = 24 VAC 12 = 24 VAC COMMON 241 = 24 VDC 240 = 24 VDC COMMON		TITLE: <b>MAP-VAC ELECTRICAL SCHEMATIC</b>	
DWG NO.: <b>MAPVAC-00001-01-REV-</b>		SCALE: NONE	DATE: 01/03/2020
		SHEET 1	OF 15

REVISIONS				
ECO	REV	DESCRIPTION	DATE	APPROVED
	A	UPDATES PER DAVE	2/26/2020	

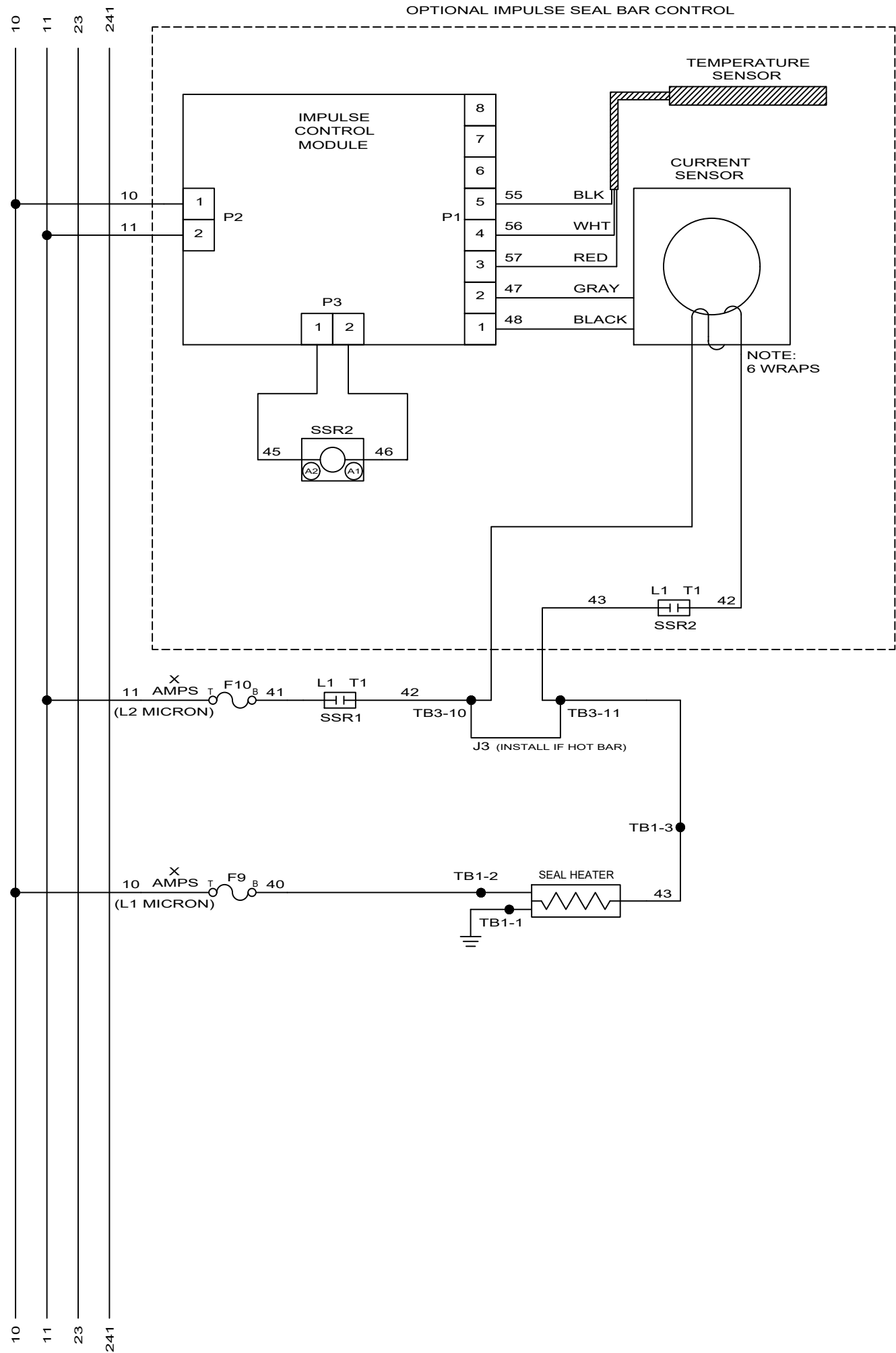

240  
12  
241

# CV·TEK

<b>LEGEND</b> 10 & 11 = 240V AC 23 = +24V AC 12 = 24 V AC COMMON 241 = 24V DC 240 = 24V DC COMMON	THIS DRAWING IS THE PROPERTY OF CV TEK, INC. AND IS TO BE CONSIDERED CONFIDENTIAL. USE OR REPRODUCTION WITHOUT THE EXPRESS PERMISSION OF THE COMPANY IS STRICTLY PROHIBITED.	APPROVED MFG: DRAWN BY: R. HILL	APPROVED ENG:	
	TOLERANCES: UNLESS OTHERWISE STATED: FRACTIONAL = ±.015 .XX = ±.015 .XXX = ±.005 DRILLED HOLE: STANDARD S.A.E.	TITLE: <b>MAP-VAC ELECTRICAL SCHEMATIC</b>	DWG NO.: <b>MAPVAC-00001-01-REV-</b>	REV -
	SCALE: NONE	DATE: 01/03/20	SHEET 2 OF 15	

240

REVISIONS		DESCRIPTION	DATE	APPROVED
ECO	REV			

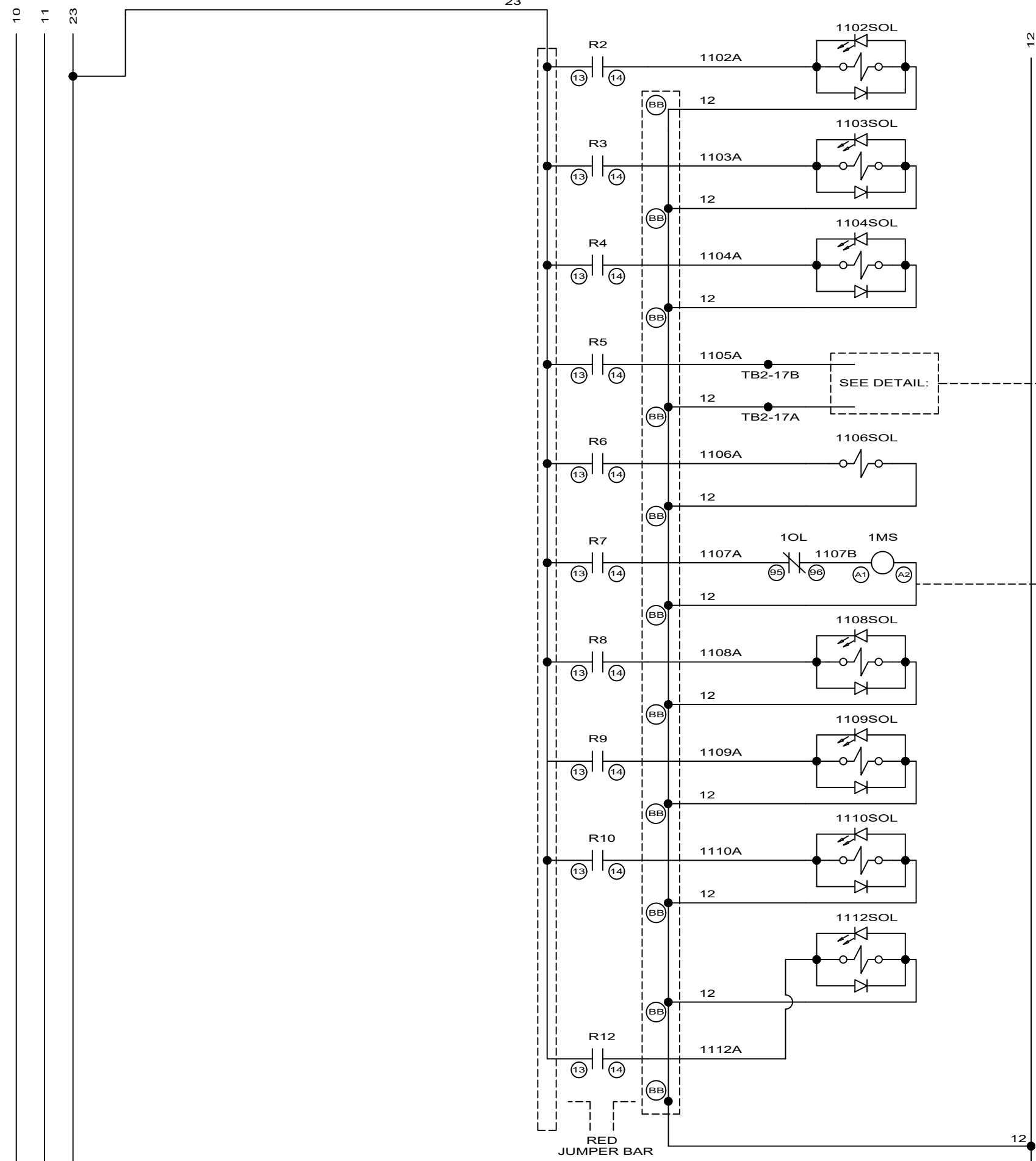

- 12 ADVANCE PROBES SOL 1
- 12 ADVANCE SEAL BAR SOL 2
- 12 OPEN/CLOSE JAW SOL 9
- 12 GAS ON SOL 4
- 12 VACUUM PUMP MOTOR STARTER
- 12 RIGHT BAG STRETCHERSOL 42 (OPTIONAL)
- 12 LEFT BAG STRETCHER SOL 43 (OPTIONAL)
- 12 BAG STR DOWN (OPTIONAL)
- 12 GAS 2 SOL 4A (OPTIONAL)
- 12 GAS 2 ON (OPTIONAL)

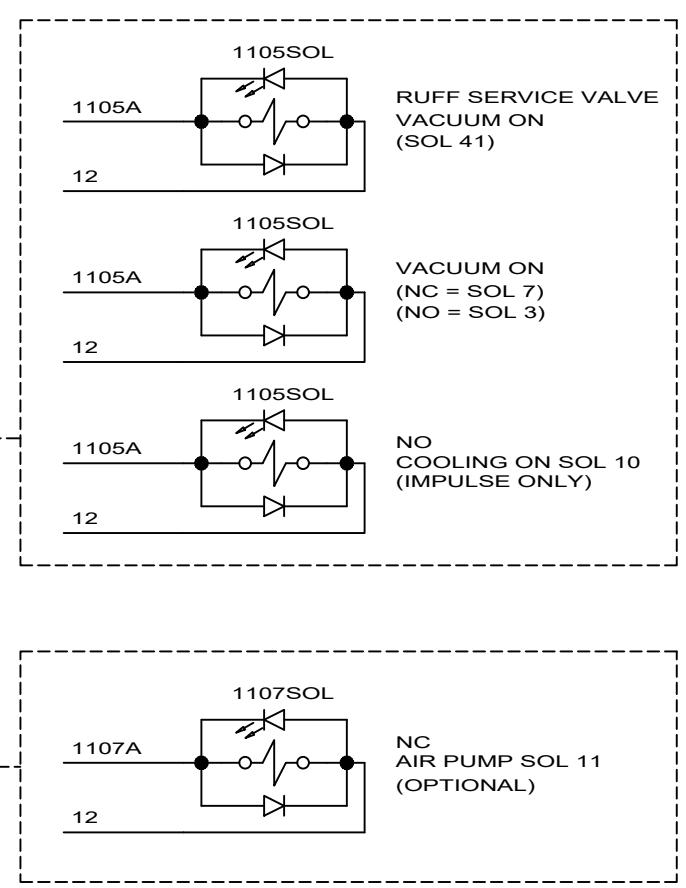

**INTERFACE RELAYS**

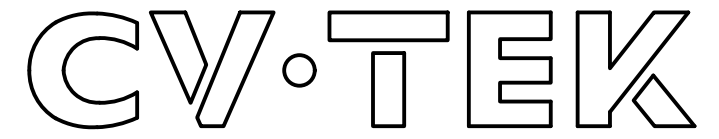

**LEGEND**  
 10 & 11 = 240 OR 120 VAC  
 23 = 24 VAC  
 12 = 24 VAC COMMON  
 241 = 24 VDC  
 240 = 24 VDC COMMON

THIS DRAWING IS THE PROPERTY OF CV TEK, INC. AND IS TO BE CONSIDERED CONFIDENTIAL. USE OR REPRODUCTION WITHOUT THE EXPRESS PERMISSION OF THE COMPANY IS STRICTLY PROHIBITED.

APPROVED MFG: \_\_\_\_\_ APPROVED ENG: \_\_\_\_\_  
 DRAWN BY: R. HILL  
 TITLE: **MAP-VAC ELECTRICAL SCHEMATIC 24 VAC VALVES**

TOLERANCES: UNLESS OTHERWISE STATED:  
 FRACTIONAL = ±.015  
 .XX = ±.015  
 .XXX = ±.005  
 DRILLED HOLE: STANDARD S.A.E.

DWG NO.: **MAPVAC-00001-01-REV-** REV: -  
 SCALE: NONE DATE: 01/03/20 SHEET 3 OF 15

REVISIONS				
ECO	REV	DESCRIPTION	DATE	APPROVED
	A	UPDATES PER DAVE	2/26/2020	

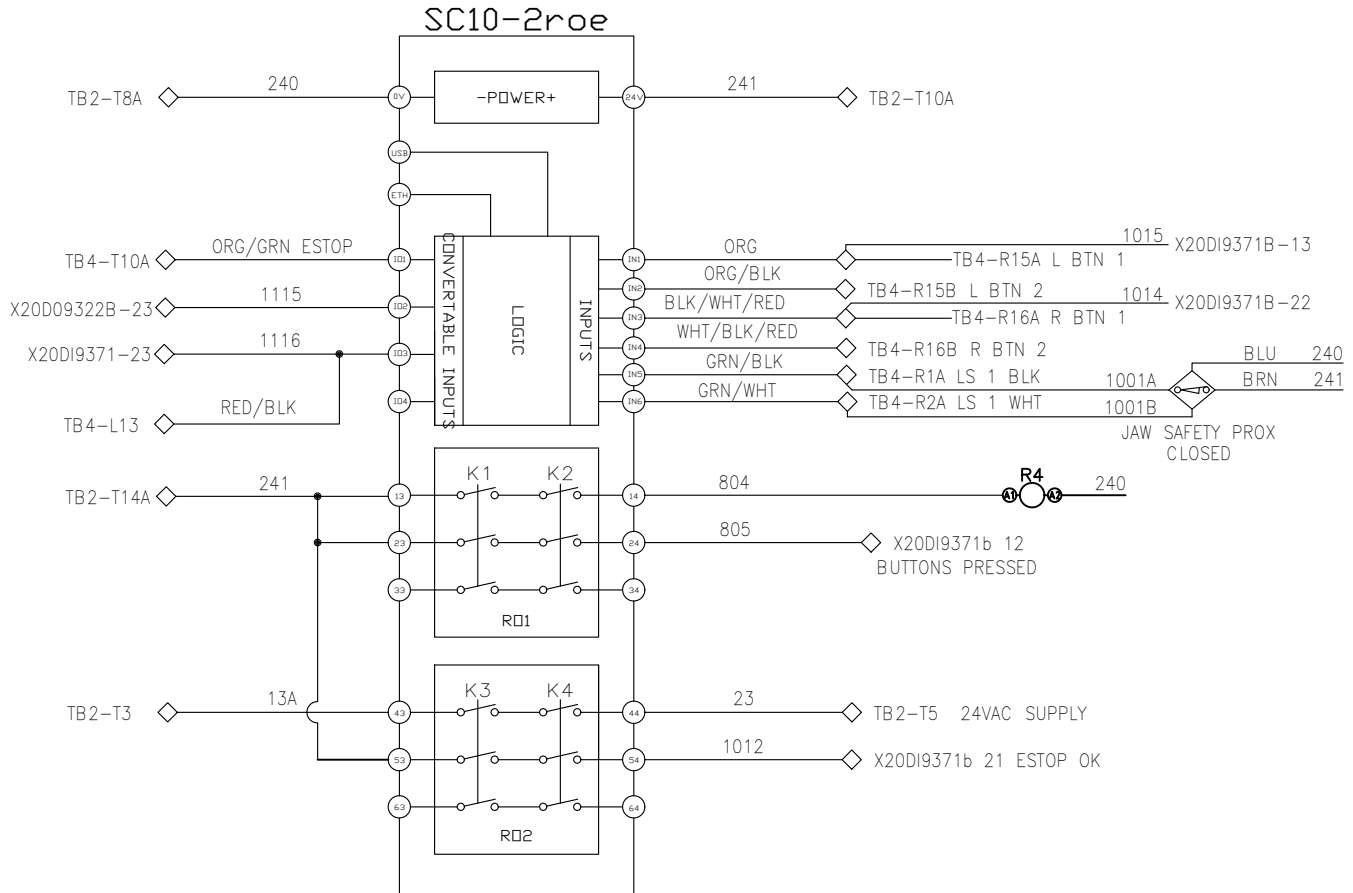

PROGRAM: MAPVAC SAFETY V1-2

# CV·TEK

**LEGEND**  
 10 & 11 = 240 DR 120 VAC  
 23 = 24 VAC  
 12 = 24 VAC COMMON  
 241 = 24 VDC  
 240 = 24 VDC COMMON

THIS DRAWING IS THE PROPERTY OF CV TEK, INC. AND IS TO BE CONSIDERED CONFIDENTIAL. USE OR REPRODUCTION WITHOUT THE EXPRESS PERMISSION OF THE COMPANY IS STRICTLY PROHIBITED.

APPROVED MFG: \_\_\_\_\_ APPROVED ENG: \_\_\_\_\_  
 DRAWN BY: R. HILL

TITLE: **MAP-VAC ELECTRICAL SCHEMATIC SAFE PLC**

TOLERANCES: UNLESS OTHERWISE STATED:  
 FRACTIONAL = ±.015  
 .XX = ±.015  
 .XXX = ±.005  
 DRILLED HOLE: STANDARD S.A.E.

DWG NO.: **MAPVAC-00001-01-REV-** REV: **-**  
 SCALE: NONE DATE: 01/03/20 SHEET 4 OF 15

REVISIONS				
ECO	REV	DESCRIPTION	DATE	APPROVED

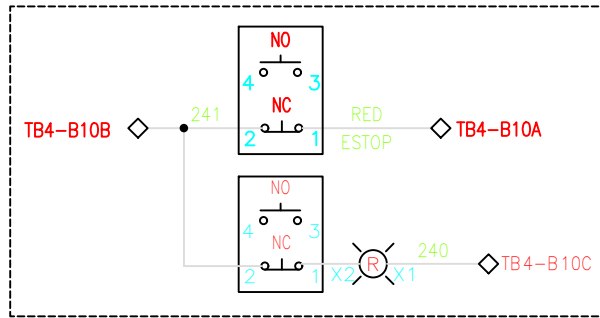

ESTOP

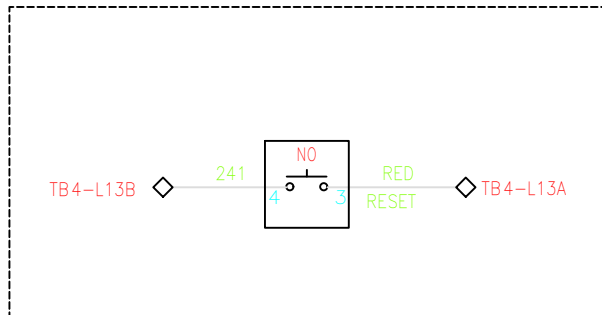

RESET

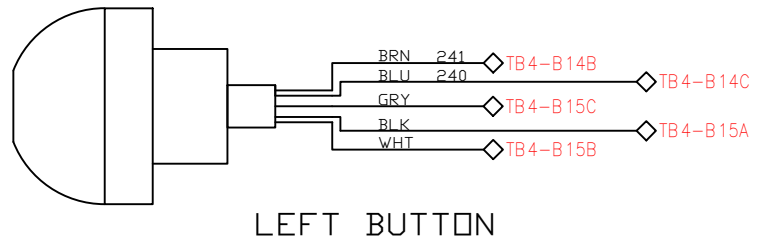

LEFT BUTTON

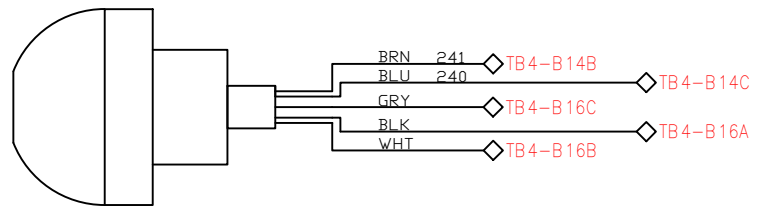

RIGHT BUTTON

BANNER PRO EDITOR  
PROGRAM: MapVac.Config  
OUTPUT 1 = NO  
OUTPUT 2 = NC

# CV·TEK

**LEGEND**  
10 & 11 = 240 DR 120 VAC  
23 = 24 VAC  
12 = 24 VAC COMMON  
241 = 24 VDC  
240 = 24 VDC COMMON

THIS DRAWING IS THE PROPERTY OF CV TEK, INC. AND IS TO BE CONSIDERED CONFIDENTIAL. USE OR REPRODUCTION WITHOUT THE EXPRESS PERMISSION OF THE COMPANY IS STRICTLY PROHIBITED.

APPROVED MFG:  
DRAWN BY: R. HILL

APPROVED ENG:

TITLE:  
**MAP-VAC ELECTRICAL SCHEMATIC  
BUTTON BOX**

TOLERANCES: UNLESS OTHERWISE STATED:  
FRACTIONAL = ±.015  
XX = ±.015  
.XXX = ±.005  
DRILLED HOLE: STANDARD S.A.E.

DWG NO.: **MAPVAC-00001-01-REV-** REV: **-**  
SCALE: NONE DATE: 01/03/20 SHEET 5 OF 15

REVISIONS				
ECO	REV	DESCRIPTION	DATE	APPROVED
	A	UPDATED PROGRAM INFORMATION	10/19/2020	

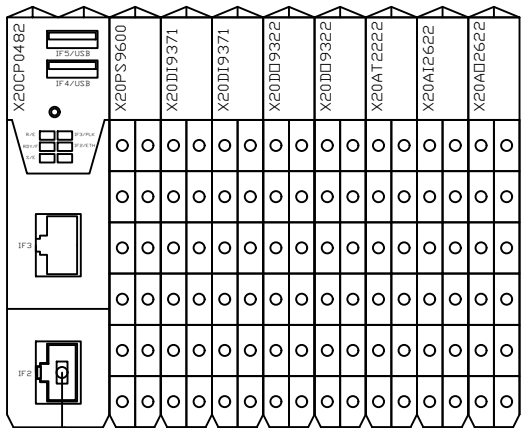

NOTE: THIS IS ALSO THE INITIAL PROGRAMMING PORT

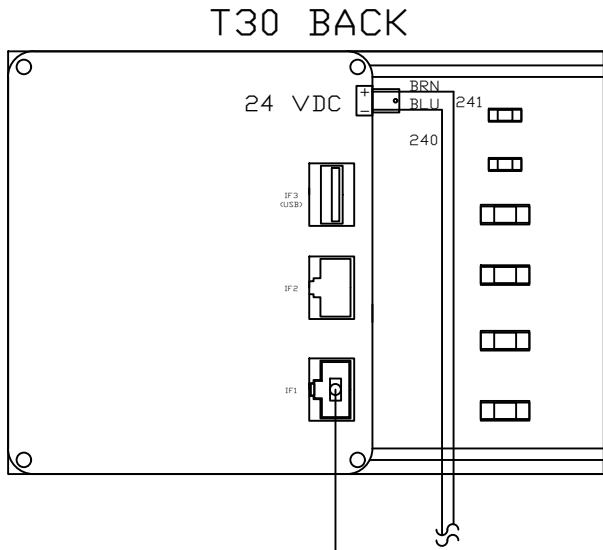

SET-UP	
PRESS FUNCTION BUTTON ON LOWER RIGHT-HAND SIDE OF THE SCREEN FOR 5 SEC TO ENTER SET-UP MODE	
START MODE	VNC
NETWORK	DHCP UNCHECKED
	IP = 10.1.1.50
	SUBNET = 255.255.255.0
HAND	OPEN SERVICE PAGE (CHECK)
	USE BUTTON IN APP (CHECK)
VNC	SERVER = 10.1.1.100
SAVE & EXIT	SAVE CHANGES

PROGRAM: MapVacV2.2  
 SET:  
 MODE = IP MANUAL  
 IP = 10.1.1.100  
 SUBNET = 255.255.255.0

# CV-TEK

**LEGEND**  
 10 & 11 = 240 DR 120  
 VAC  
 23 = 24 VAC  
 12 = 24 VAC COMMON  
 241 = 24 VDC  
 240 = 24 VDC COMMON

THIS DRAWING IS THE PROPERTY OF CV TEK, INC. AND IS TO BE CONSIDERED CONFIDENTIAL. USE OR REPRODUCTION WITHOUT THE EXPRESS PERMISSION OF THE COMPANY IS STRICTLY PROHIBITED.

APPROVED MFG:  
 DRAWN BY: R. HILL

APPROVED ENG:

TITLE: MAP-VAC ELECTRICAL SCHEMATIC PLC LAYOUT

TOLERANCES: UNLESS OTHERWISE STATED:  
 FRACTIONAL = ±.015  
 .XX = ±.015  
 .XXX = ±.005  
 DRILLED HOLE: STANDARD S.A.E.

REV: —  
 DWG NO.: MAPVAC-00001-01-REV-  
 SCALE: NONE DATE: 01/03/20 SHEET 6 OF 15

REVISIONS				
ECO	REV	DESCRIPTION	DATE	APPROVED
	A	UPDATES PER DAVE	2/26/2020	
	B	UPDATED LINE 1010 DESTINATION	10/19/2020	

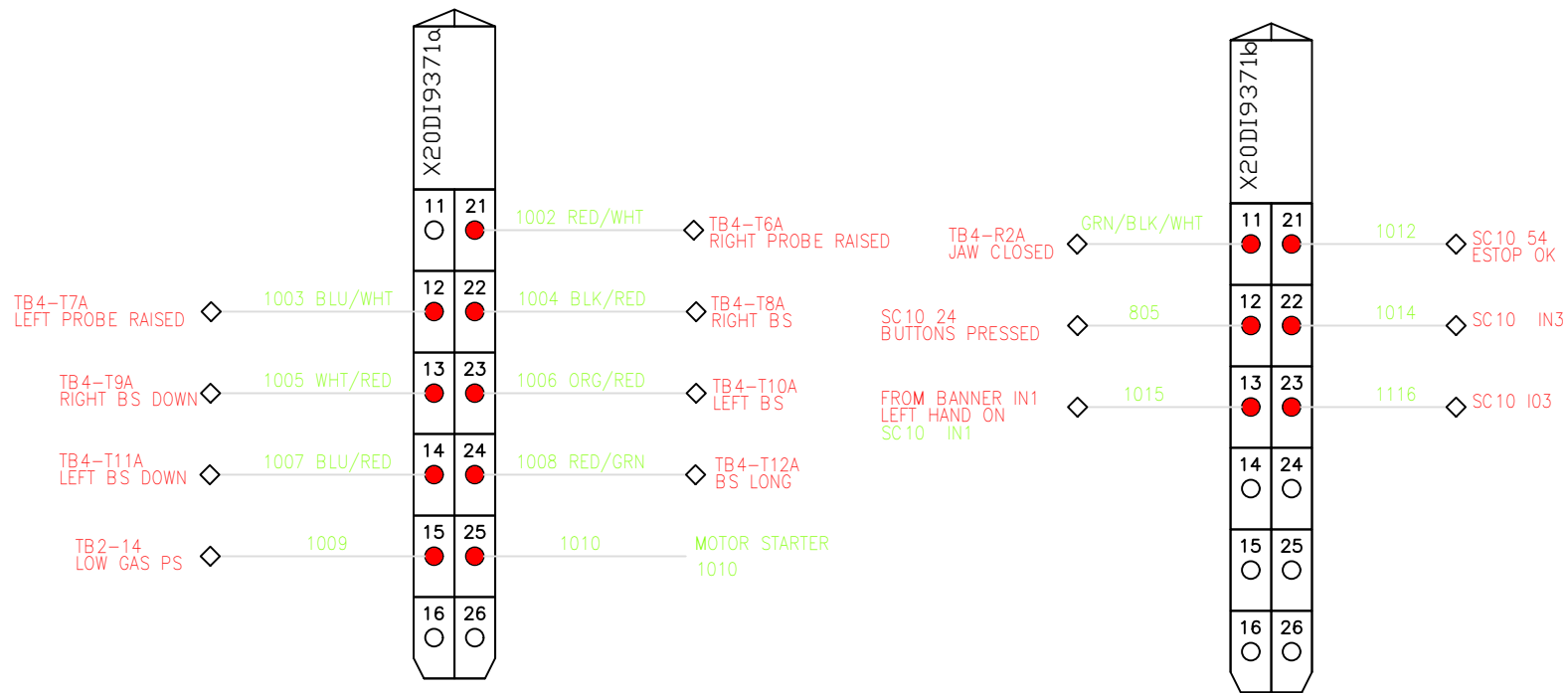

# CV-TEK

**LEGEND**  
 10 & 11 = 240 DR 120 VAC  
 23 = 24 VAC  
 12 = 24 VAC COMMON  
 241 = 24 VDC  
 240 = 24 VDC COMMON

THIS DRAWING IS THE PROPERTY OF CV TEK, INC. AND IS TO BE CONSIDERED CONFIDENTIAL. USE OR REPRODUCTION WITHOUT THE EXPRESS PERMISSION OF THE COMPANY IS STRICTLY PROHIBITED.

APPROVED MFG: \_\_\_\_\_ APPROVED ENG: \_\_\_\_\_  
 DRAWN BY: R. HILL

TITLE: MAP-VAC ELECTRICAL SCHEMATIC INPUTS

TOLERANCES: UNLESS OTHERWISE STATED:  
 FRACTIONAL = ±.015  
 XX = ±.015  
 .XXX = ±.005  
 DRILLED HOLE: STANDARD S.A.E.

DWG NO.: MAPVAC-00001-01-REV-  
 SCALE: NONE DATE: 01/03/20 SHEET 7 OF 15

REVISIONS				
ECO	REV	DESCRIPTION	DATE	APPROVED

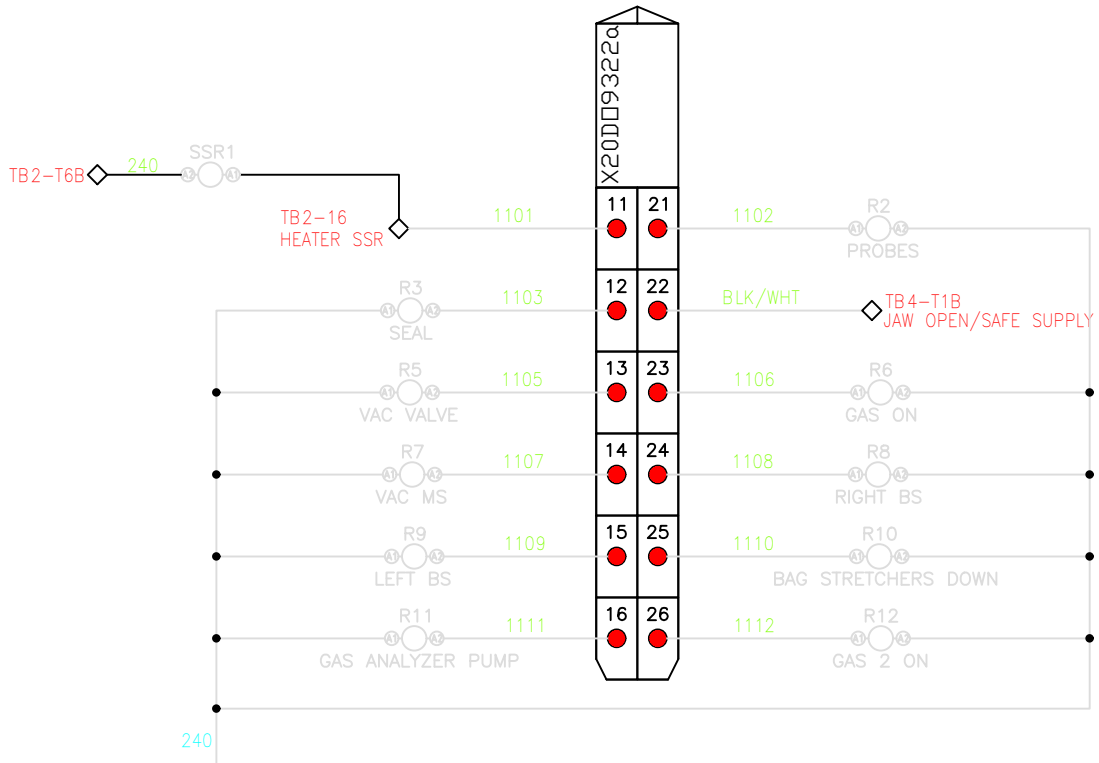

# CV-TEK

**LEGEND**  
 10 & 11 = 240 DR 120 VAC  
 23 = 24 VAC  
 12 = 24 VAC COMMON  
 241 = 24 VDC  
 240 = 24 VDC COMMON

THIS DRAWING IS THE PROPERTY OF CV TEK, INC. AND IS TO BE CONSIDERED CONFIDENTIAL. USE OR REPRODUCTION WITHOUT THE EXPRESS PERMISSION OF THE COMPANY IS STRICTLY PROHIBITED.

APPROVED MFG: \_\_\_\_\_ APPROVED ENG: \_\_\_\_\_  
 DRAWN BY: R. HILL

TITLE: MAP-VAC ELECTRICAL SCHEMATIC OUTPUTS

TOLERANCES: UNLESS OTHERWISE STATED:  
 FRACTIONAL = ±.015  
 .XX = ±.015  
 .XXX = ±.005  
 DRILLED HOLE: STANDARD S.A.E.

DWG NO.: MAPVAC-00001-01-REV-  
 SCALE: NONE DATE: 01/03/20 SHEET 8 OF 15

REVISIONS				
ECO	REV	DESCRIPTION	DATE	APPROVED
	A	UPDATES PER DAVE	2/26/2020	

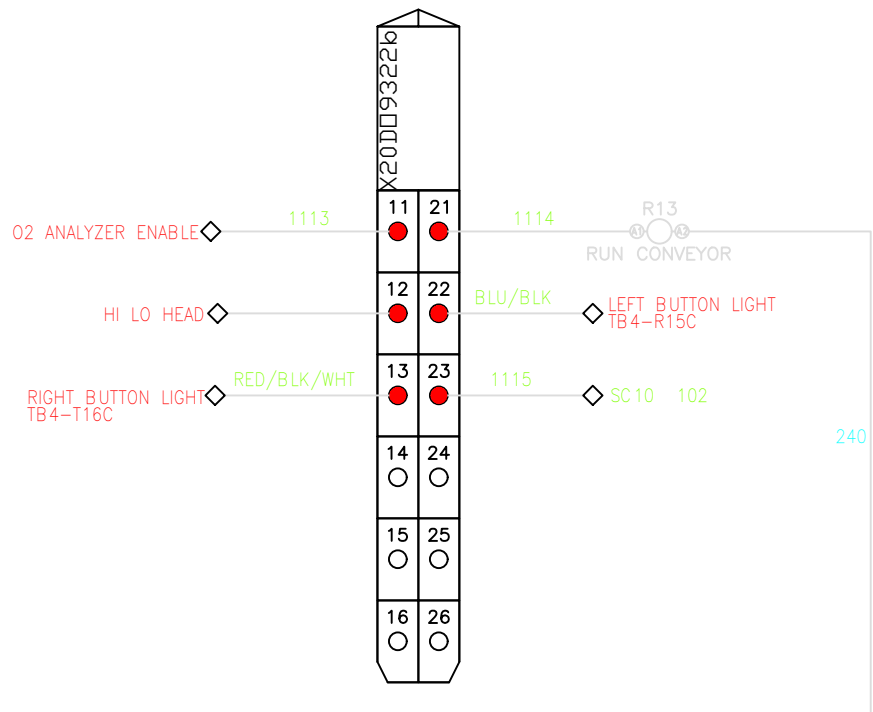

# CV-TEK

**LEGEND**  
 10 & 11 = 240 DR 120 VAC  
 23 = 24 VAC  
 12 = 24 VAC COMMON  
 241 = 24 VDC  
 240 = 24 VDC COMMON

THIS DRAWING IS THE PROPERTY OF CV TEK, INC. AND IS TO BE CONSIDERED CONFIDENTIAL. USE OR REPRODUCTION WITHOUT THE EXPRESS PERMISSION OF THE COMPANY IS STRICTLY PROHIBITED.

APPROVED MFG: \_\_\_\_\_ APPROVED ENG: \_\_\_\_\_  
 DRAWN BY: R. HILL

TITLE: MAP-VAC ELECTRICAL SCHEMATIC OUTPUTS CONT'D

TOLERANCES: UNLESS OTHERWISE STATED:  
 FRACTIONAL = ±.015  
 .XX = ±.015  
 .XXX = ±.005  
 DRILLED HOLE: STANDARD S.A.E.

DWG NO.: MAPVAC-00001-01-REV-  
 SCALE: NONE DATE: 01/03/20 SHEET 9 OF 15

REVISIONS				
ECO	REV	DESCRIPTION	DATE	APPROVED
	A	UPDATES PER DAVE	2/26/2020	

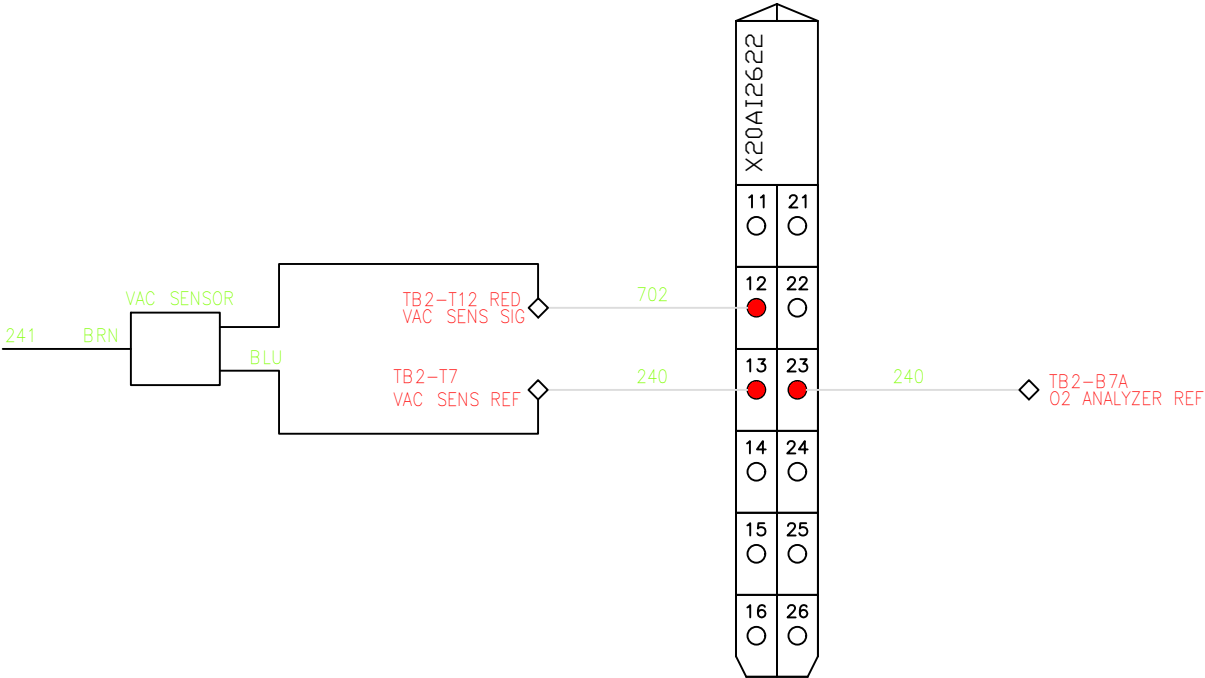

# CV-TEK

**LEGEND**  
 10 & 11 = 240 DR 120 VAC  
 23 = 24 VAC  
 12 = 24 VAC COMMON  
 241 = 24 VDC  
 240 = 24 VDC COMMON

THIS DRAWING IS THE PROPERTY OF CV TEK, INC. AND IS TO BE CONSIDERED CONFIDENTIAL. USE OR REPRODUCTION WITHOUT THE EXPRESS PERMISSION OF THE COMPANY IS STRICTLY PROHIBITED.

APPROVED MFG: \_\_\_\_\_ APPROVED ENG: \_\_\_\_\_  
 DRAWN BY: R. HILL  
 TITLE: MAP-VAC ELECTRICAL SCHEMATIC ANALOG I/O

TOLERANCES: UNLESS OTHERWISE STATED:  
 FRACTIONAL = ±.015  
 .XX = ±.015  
 .XXX = ±.005  
 DRILLED HOLE: STANDARD S.A.E.

DWG NO.: MAPVAC-00001-01-REV-  
 SCALE: NONE DATE: 01/03/20 SHEET 10 OF 15

REVISIONS				
ECO	REV	DESCRIPTION	DATE	APPROVED

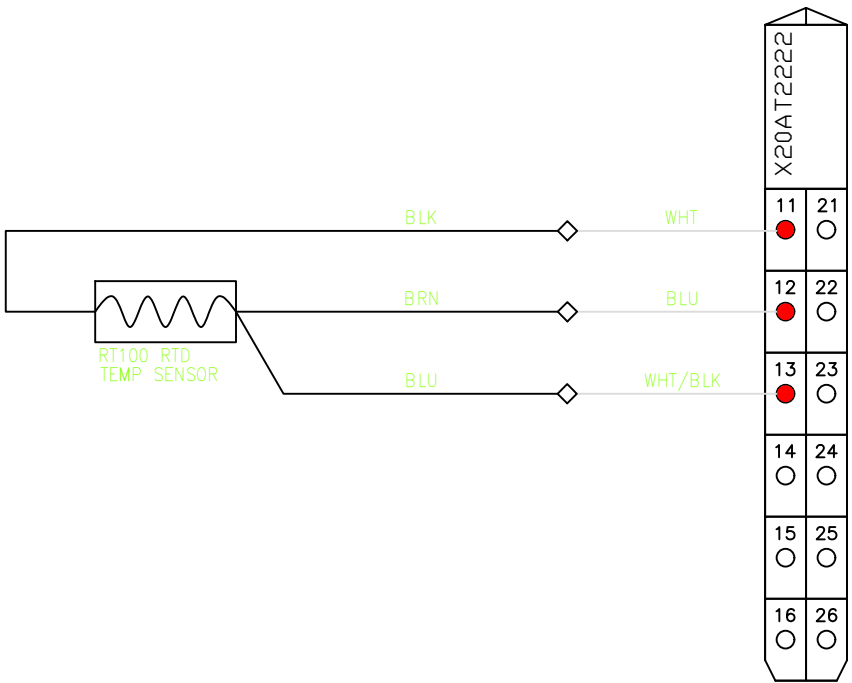

# CV·TEK

**LEGEND**  
 10 & 11 = 240 DR 120  
 VAC  
 23 = 24 VAC  
 12 = 24 VAC COMMON  
 241 = 24 VDC  
 240 = 24 VDC COMMON

THIS DRAWING IS THE  
 PROPERTY OF CV TEK, INC.  
 AND IS TO BE CONSIDERED  
 CONFIDENTIAL. USE OR  
 REPRODUCTION WITHOUT  
 THE EXPRESS PERMISSION  
 OF THE COMPANY IS  
 STRICTLY PROHIBITED.

APPROVED MFG: \_\_\_\_\_ APPROVED ENG: \_\_\_\_\_  
 DRAWN BY: R. HILL  
 TITLE: MAP-VAC ELECTRICAL SCHEMATIC  
 ANALOG TEMP

TOLERANCES: UNLESS OTHERWISE  
 STATED:  
 FRACTIONAL = ±.015  
 .XX = ±.015  
 .XXX = ±.005  
 DRILLED HOLE: STANDARD S.A.E.

DWG NO.: MAPVAC-00001-01-REV-  
 SCALE: NONE DATE: 01/03/20 SHEET 11 OF 15  
 REV: -

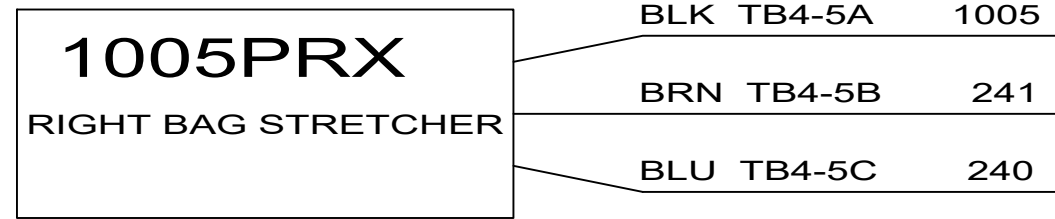
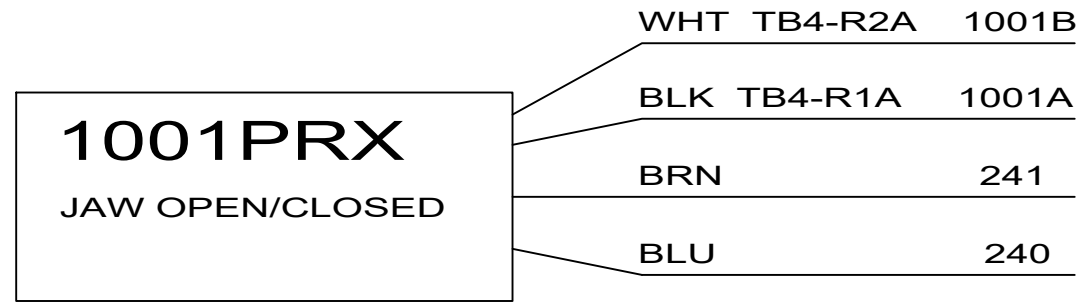

(OPTIONAL)

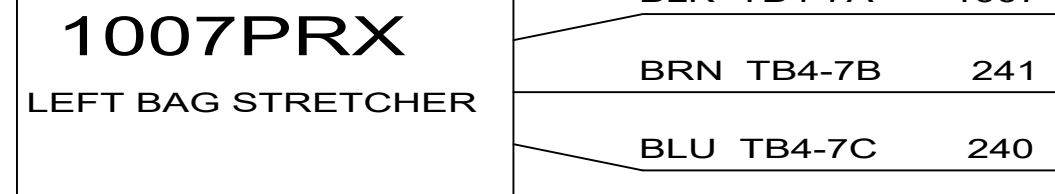
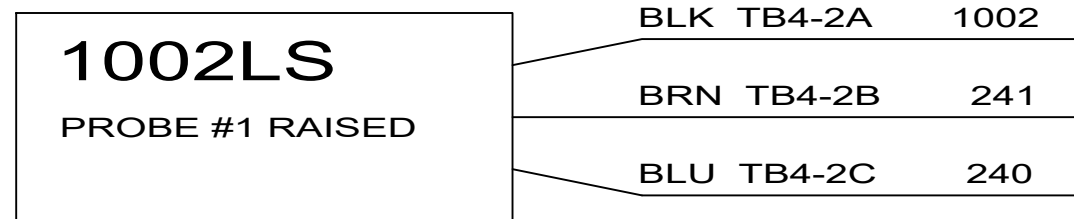

(OPTIONAL)

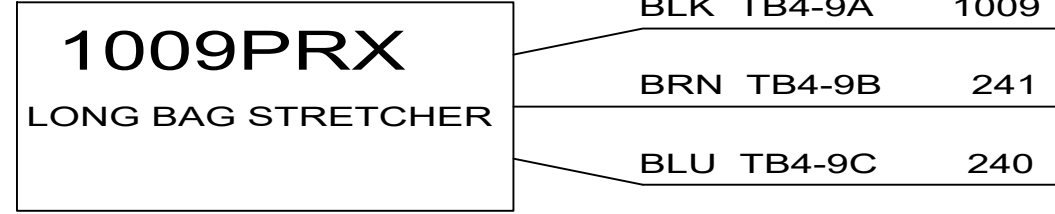
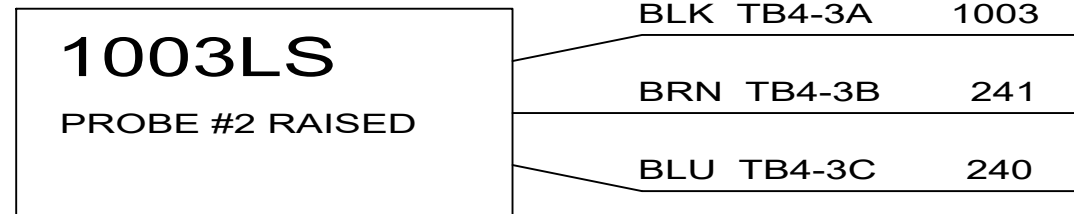

(OPTIONAL)

(CYLINDER SWITCH)

(CYLINDER SWITCH)

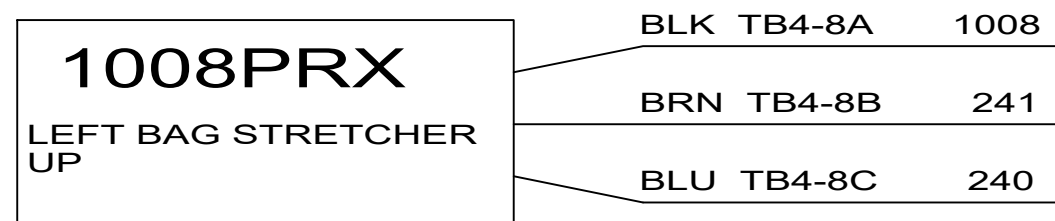
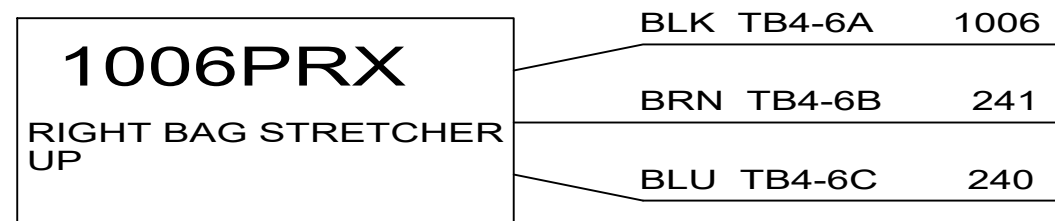

**NOTE: ALL TYPE PNP**

# CV•TEK

**LEGEND**  
 10 & 11 = 240 OR 120 VAC  
 23 = 24 VAC  
 12 = 24 VAC COMMON  
 241 = 24 VDC  
 240 = 24 VDC COMMON

THIS DRAWING IS THE PROPERTY OF CV TEK, INC. AND IS TO BE CONSIDERED CONFIDENTIAL. USE OR REPRODUCTION WITHOUT THE EXPRESS PERMISSION OF THE COMPANY IS STRICTLY PROHIBITED.

TOLERANCES: UNLESS OTHERWISE STATED:  
 FRACTIONAL = ±.015  
 .XX = ±.015  
 .XXX = ±.005  
 DRILLED HOLE: STANDARD S.A.E.

APPROVED MFG: \_\_\_\_\_ APPROVED ENG: \_\_\_\_\_  
 DRAWN BY: R. HILL

TITLE: **MAP-VAC ELECTRICAL SCHEMATIC PROX SENSORS**

DWG NO.: **MAPVAC-00001-01-REV-** REV: **-**

SCALE: NONE DATE: 01/03/20 SHEET 12 OF 15

REVISIONS			
ECO	REV	DESCRIPTION	DATE

DISPLAY BOX

BLK 240 TB4-L12C
RED 241 TB4-L12B
GRN GND TB4-R18
WHT TB4-R17A RTD+
BLU TB4-R17B RTD-
WHT/BLK TB4-R17C RTD GND
GRN/BLK TB4-R1A LS1
GRN/WHT TB4-R2A LS1
GRN/BLK/WHT RB4-R2A LS1
BLK/WHT TB4-R1B LS1 SUPPLY
RED/WHT TB4-R3A R PROBE
BLU/WHT TB4-R4A L PROBE
BLK/RED TB4-R5A R BS
WHT/RED TB4-R6A R BSD
ORG/RED TB4-R7A L BS
BLU/RED TB4-R8A L BSD
RED/GRN TB4-R9A BS LONG
ORG/GRN TB4-R10 ESTOP
ORG TB4-R15A L BTN BLK 1
ORG/BLK TB4-R15B L BTN WHT 2
BLU/BLK TB4-R15C L BTN GRY 3
BLK/WHT/RED TB4-R16A R BTN BLK 1
WHT/BLK/RED TB4-R16B R BTN WHT 2
RED/BLK/WHT RB4-R16C R BTN GRY 3
RED/BLK ESTOP RESET

DOUBLE FERRULE

BELDEN #9626 25X18AWG

MAIN ENCLOSURE

BLK 240 TB2-6A
RED 241 TB2-9A
GRN GND TB1-1
WHT X20AT2222 11
BLU X20AT2222 12
WHT/BLK X20AT2222 13
GRN/BLK SC10-2r0e IN5
GRN/WHT SC10-2r0e IN6
GRN/BLK/WHT X20DI9371b 11
BLK/WHT X20DD9322 22
RED/WHT X20DI9372 21
BLU/WHT X20DI9372 12
BLK/RED X20DI9372 22
WHT/RED X20DI9372 13
ORG/RED X20DI9372 23
BLU/RED X20DI9372 14
RED/GRN X20DI9372 24
ORG/GRN SC10-2r0e IO1
ORG SC10-2r0e IN1
ORG/BLK SC10-2r0e IN2
BLU/BLK X20DD9322b 22
BLK/WHT/RED SC10-2r0e IN3
WHT/BLK/RED SC10-2r0e IN4
RED/BLK/WHT X20DD9322b 13
RED/BLK SC10-2r0e IO3

1116

RESET

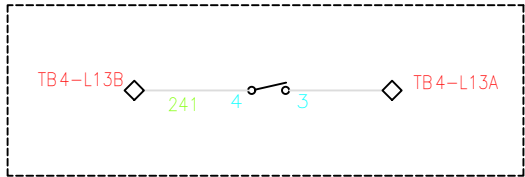

# CV-TEK

**LEGEND**  
 10 & 11 = 240 DR 120 VAC  
 23 = 24 VAC  
 12 = 24 VAC COMMON  
 241 = 24 VDC COMMON  
 240 = 24 VDC COMMON

THIS DRAWING IS THE PROPERTY OF CV TEK, INC. AND IS TO BE CONSIDERED CONFIDENTIAL. USE OR REPRODUCTION WITHOUT THE EXPRESS PERMISSION OF THE COMPANY IS STRICTLY PROHIBITED.

APPROVED MFG: DRAWN BY: R. HILL

APPROVED ENG:

TITLE: MAP-VAC ELECTRICAL SCHEMATIC 25 COND CABLE

TOLERANCES: UNLESS OTHERWISE STATED:  
 FRACTIONAL = ±.015  
 .XX = ±.015  
 .XXX = ±.005  
 DRILLED HOLE: STANDARD S.A.E.

EWG NO.: MAPVAC-00001-01-REV-  
 SCALE: NONE DATE: 01/03/20 SHEET 13 OF 15

REVISIONS				
ECO	REV	DESCRIPTION	DATE	APPROVED
	A	UPDATES PER DAVE	2/26/2020	

TB4-1	BC <input type="radio"/>	BB <input type="radio"/>	BA <input type="radio"/>	1 LS1	<input type="radio"/>	TA	<input type="radio"/>	TB	<input type="radio"/>	TC
TB4-2	BC <input type="radio"/>	BB <input type="radio"/>	BA <input type="radio"/>	2 LS1	<input type="radio"/>	TA	<input type="radio"/>	TB	<input type="radio"/>	TC
TB4-3	BC <input type="radio"/>	BB <input type="radio"/>	BA <input type="radio"/>	3 PROBE L	<input type="radio"/>	TA				
TB4-4	BC <input type="radio"/>	BB <input type="radio"/>	BA <input type="radio"/>	4 PROBE R	<input type="radio"/>	TA				
TB4-5	BC <input type="radio"/>	BB <input type="radio"/>	BA <input type="radio"/>	5 RIGHT BS	<input type="radio"/>	TA				
TB4-6	BC <input type="radio"/>	BB <input type="radio"/>	BA <input type="radio"/>	6 RIGHT BS	<input type="radio"/>	TA				
TB4-7	BC <input type="radio"/>	BB <input type="radio"/>	BA <input type="radio"/>	7 LEFT BS	<input type="radio"/>	TA				
TB4-8	BC <input type="radio"/>	BB <input type="radio"/>	BA <input type="radio"/>	8 LEFT BS UP	<input type="radio"/>	TA				
TB4-9	BC <input type="radio"/>	BB <input type="radio"/>	BA <input type="radio"/>	9 LONG BS	<input type="radio"/>	TA				
TB4-10	BC <input type="radio"/>	BB <input type="radio"/>	BA <input type="radio"/>	10 ESTOP	<input type="radio"/>	TA				
TB4-11	BC <input type="radio"/>	BB <input type="radio"/>	BA <input type="radio"/>	11 24VDC PLC	<input type="radio"/>	TA				
TB4-12	BC <input type="radio"/>	BB <input type="radio"/>	BA <input type="radio"/>	12 24VDC	<input type="radio"/>	TA				
TB4-13	BC <input type="radio"/>	BB <input type="radio"/>	BA <input type="radio"/>	13 RESET	<input type="radio"/>	TA				
TB4-14	BC <input type="radio"/>	BB <input type="radio"/>	BA <input type="radio"/>	14 24VDC	<input type="radio"/>	TA				
TB4-15	BC <input type="radio"/>	BB <input type="radio"/>	BA <input type="radio"/>	15 L BUTTON	<input type="radio"/>	TA	<input type="radio"/>	TB	<input type="radio"/>	TC
TB4-16	BC <input type="radio"/>	BB <input type="radio"/>	BA <input type="radio"/>	16 R BUTTON	<input type="radio"/>	TA	<input type="radio"/>	TB	<input type="radio"/>	TC
TB4-17	BC <input type="radio"/>	BB <input type="radio"/>	BA <input type="radio"/>	17 RTD	<input type="radio"/>	TA	<input type="radio"/>	TB	<input type="radio"/>	TC
TB4-18			BA <input type="radio"/>	18 GND	<input type="radio"/>	TA				

# CV-TEK

**LEGEND**  
 10 & 11 = 240 DR 120 VAC  
 23 = 24 VAC  
 12 = 24 VAC COMMON  
 241 = 24 VDC  
 240 = 24 VDC COMMON

THIS DRAWING IS THE PROPERTY OF CV TEK, INC. AND IS TO BE CONSIDERED CONFIDENTIAL. USE OR REPRODUCTION WITHOUT THE EXPRESS PERMISSION OF THE COMPANY IS STRICTLY PROHIBITED.

APPROVED MFG: \_\_\_\_\_ APPROVED ENG: \_\_\_\_\_  
 DRAWN BY: R. HILL  
 TITLE: MAP-VAC ELECTRICAL SCHEMATIC JUNCTION BOX

TOLERANCES: UNLESS OTHERWISE STATED:  
 FRACTIONAL = ±.015  
 .XX = ±.015  
 .XXX = ±.005  
 DRILLED HOLE: STANDARD S.A.E.

DWG NO.: MAPVAC-00001-01-REV-  
 SCALE: NONE DATE: 01/03/20 SHEET 14 OF 15  
 REV: -

# FUSE SIZE CHARTS

## HOT BAR

ECO	REV	REVISIONS	DESCRIPTION	DATE	APPROVED
-----	-----	-----------	-------------	------	----------

208-220 VAC 1 PHASE 50/60HZ			
FUSE	10CFM	PIAB	ALTRAN
F1	AM-4	NONE	
F2	AM-4	NONE	
F3	NONE	NONE	
F4	AM-2	AM-2	AM-16
F5	AM-2	AM-2	AM-16
F6	AM-4	AM-4	
F7	AM-1	AM-1	
F8	AM-1	AM-1	
F9	AM-8	AM-8	
F10	AM-8	AM-8	
MOTOR STARTER OL SETTING			
	3.8	NA	

380-415 VAC 1 PHASE 50HZ			
FUSE	PIAB	-	-
F1	NONE		
F2	NONE		
F3	NONE		
F4	AM-10		
F5	AM-10		
F6	AM-4		
F7	AM-1		
F8	AM1		
F9	AM-8		
F10	AM-8		
MOTOR STARTER OL SETTING			
	NA		

440-480 VAC 1 PHASE 60HZ			
FUSE	PIAB	-	-
F1	NONE		
F2	NONE		
F3	NONE		
F4	AM-8		
F5	AM-8		
F6	AM-4		
F7	AM-1		
F8	AM-1		
F9	AM-8		
F10	AM-8		
MOTOR STARTER OL SETTING			
	NA		

575 VAC 3 PHASE 60HZ							
FUSE	10CFM	21CFM	28CFM	35CFM	LEM15/20	LEM60	40CFM
F1	AM-	AM-	AM-	AM-	AM-	AM-	AM-5
F2	AM-	AM-	AM-	AM-	AM-	AM-	AM-5
F3	AM-	AM-	AM-	AM-	AM-	AM-	AM-5
F4	AM-	AM-	AM-	AM-	AM-	AM-	AM-7
F5	AM-	AM-	AM-	AM-	AM-	AM-	AM-7
F6	AM-	AM-	AM-	AM-	AM-	AM-	AM-4
F7	AM-	AM-	AM-	AM-	AM-	AM-	AM-1
F8	AM-	AM-	AM-	AM-	AM-	AM-	AM-1
F9	AM-	AM-	AM-	AM-	AM-	AM-	AM-8
F10	AM-	AM-	AM-	AM-	AM-	AM-	AM-8
MOTOR STARTER OL SETTING							
							3.5

208-240 VAC 3 PHASE 50/60HZ								
FUSE	10CFM	21CFM	28CFM	35CFM	LEM15/20	LEM60	ALTRAN	40CFM
F1	AM-4	AM-8	AM-10	AM-10	AM-6	AM-16		AM-12
F2	AM-4	AM-8	AM-10	AM-10	AM-6	AM-16		AM-12
F3	AM-4	AM-8	AM-10	AM-10	AM-6	AM-16		AM-12
F4	AM-2	AM-2	AM-2	AM-2	AM-2	AM-2	AM-16	AM-2
F5	AM-2	AM-2	AM-2	AM-2	AM-2	AM-2	AM-16	AM-2
F6	AM-4	AM-4	AM-4	AM-4	AM-4	AM-4		AM-4
F7	AM-1	AM-1	AM-1	AM-1	AM-1	AM-1		AM-1
F8	AM-1	AM-1	AM-1	AM-1	AM-1	AM-1		AM-1
F9	AM-8	AM-8	AM-8	AM-8	AM-8	AM-8		AM-8
F10	AM-8	AM-8	AM-8	AM-8	AM-8	AM-8		AM-8
MOTOR STARTER OL SETTING								
	2.6	4.8	6.0	6.1	4.0	8.5		9.0

380-415 VAC 3 PHASE 50HZ							
FUSE	10CFM	21CFM	28CFM	35CFM	LEM15/20	LEM60	40CFM
F1	AM-4	AM-4	AM-6	AM-6	AM-4	AM-6	AM-6
F2	AM-4	AM-4	AM-6	AM-6	AM-4	AM-6	AM-6
F3	AM-4	AM-4	AM-6	AM-6	AM-4	AM-6	AM-6
F4	AM-10	AM-10	AM-10	AM-10	AM-10	AM-10	AM-10
F5	AM-10	AM-10	AM-10	AM-10	AM-10	AM-10	AM-10
F6	AM-4	AM-4	AM-4	AM-4	AM-4	AM-4	AM-4
F7	AM-1	AM-1	AM-1	AM-1	AM-1	AM-1	AM-1
F8	AM-1	AM-1	AM-1	AM-1	AM-1	AM-1	AM-1
F9	AM-8	AM-8	AM-8	AM-8	AM-8	AM-8	AM-8
F10	AM-8	AM-8	AM-8	AM-8	AM-8	AM-8	AM-8
MOTOR STARTER OL SETTING							
	1.6	2.0	3.3	3.5	2.5	3.9	3.9

440-480 VAC 3 PHASE 60HZ							
FUSE	10CFM	21CFM	28CFM	35CFM	LEM15/20	LEM60	40CFM
F1	AM-4	AM-4	AM-6	AM-6	AM-4	AM-6	AM-6
F2	AM-4	AM-4	AM-6	AM-6	AM-4	AM-6	AM-6
F3	AM-4	AM-4	AM-6	AM-6	AM-4	AM-6	AM-6
F4	AM-8	AM-8	AM-8	AM-8	AM-8	AM-8	AM-8
F5	AM-8	AM-8	AM-8	AM-8	AM-8	AM-8	AM-8
F6	AM-4	AM-4	AM-4	AM-4	AM-4	AM-4	AM-4
F7	AM-1	AM-1	AM-1	AM-1	AM-1	AM-1	AM-1
F8	AM-1	AM-1	AM-1	AM-1	AM-1	AM-1	AM-1
F9	AM-8	AM-8	AM-8	AM-8	AM-8	AM-8	AM-8
F10	AM-8	AM-8	AM-8	AM-8	AM-8	AM-8	AM-8
MOTOR STARTER OL SETTING							
	1.3	2.4	3.0	2.8	2.5	3.9	5.0

## IMPULSE

208-240 VAC 3 PHASE 50/60HZ						
FUSE	10CFM	21CFM	28CFM	35CFM	LEM15/20	LEM60
F1	AM-4	AM-8	AM-10	AM-10	AM-6	AM-16
F2	AM-4	AM-8	AM-10	AM-10	AM-6	AM-16
F3	AM-4	AM-8	AM-10	AM-10	AM-6	AM-16
F4	AM-16	AM-16	AM-16	AM-16	AM-16	AM-16
F5	AM-16	AM-16	AM-16	AM-16	AM-16	AM-16
F6	AM-4	AM-4	AM-4	AM-4	AM-4	AM-4
F7	AM-1	AM-1	AM-1	AM-1	AM-1	AM-1
F8	AM-1	AM-1	AM-1	AM-1	AM-1	AM-1
F9	AM-20	AM-20	AM-20	AM-20	AM-20	AM-20
F10	AM-20	AM-20	AM-20	AM-20	AM-20	AM-20
MOTOR STARTER OL SETTING						
	2.6	4.8	6.0	6.1	4.0	8.5

STANDARD  
HIGH ENERGY

380-415 VAC 3 PHASE 50HZ							
FUSE	10CFM	21CFM	28CFM	35CFM	LEM15/20	LEM60	LEM60
F1	AM-4	AM-4	AM-6	AM-6	AM-4	AM-6	AM-6
F2	AM-4	AM-4	AM-6	AM-6	AM-4	AM-6	AM-6
F3	AM-4	AM-4	AM-6	AM-6	AM-4	AM-6	AM-6
F4	AM-10	AM-10	AM-10	AM-10	AM-10	AM-10	AM-10
F5	AM-10	AM-10	AM-10	AM-10	AM-10	AM-10	AM-10
F6	AM-4	AM-4	AM-4	AM-4	AM-4	AM-4	AM-4
F7	AM-1	AM-1	AM-1	AM-1	AM-1	AM-1	AM-1
F8	AM-1	AM-1	AM-1	AM-1	AM-1	AM-1	AM-1
F9	AM-20	AM-20	AM-20	AM-20	AM-20	AM-20	AM-20
F10	AM-20	AM-20	AM-20	AM-20	AM-20	AM-20	AM-20
MOTOR STARTER OL SETTING							
	1.6	2.0	3.3	3.5	2.5	3.9	3.9

STANDARD  
HIGH ENERGY

440-480 VAC 3 PHASE 60HZ						
FUSE	10CFM	21CFM	28CFM	35CFM	LEM15/20	LEM60
F1	AM-4	AM-4	AM-6	AM-6	AM-4	AM-6
F2	AM-4	AM-4	AM-6	AM-6	AM-4	AM-6
F3	AM-4	AM-4	AM-6	AM-6	AM-4	AM-6
F4	AM-8	AM-8	AM-8	AM-8	AM-8	AM-8
F5	AM-8	AM-8	AM-8	AM-8	AM-8	AM-8
F6	AM-4	AM-4	AM-4	AM-4	AM-4	AM-4
F7	AM-1	AM-1	AM-1	AM-1	AM-1	AM-1
F8	AM-1	AM-1	AM-1	AM-1	AM-1	AM-1
F9	AM-20	AM-20	AM-20	AM-20	AM-20	AM-20
F10	AM-20	AM-20	AM-20	AM-20	AM-20	AM-20
MOTOR STARTER OL SETTING						
	1.3	2.4	3.5	2.8	2.5	3.9

STANDARD  
HIGH ENERGY

208-220 VAC 1 PHASE 50/60HZ			
FUSE	PIAB	-	-
F1	NONE		
F2	NONE		
F3	NONE		
F4	AM-16		
F5	AM-16		
F6	AM-4		
F7	AM-1		
F8	AM-1		
F9	AM-20		
F10	AM-20		
MOTOR STARTER OL SETTING			

STANDARD  
HIGH ENERGY

380-415 VAC 1 PHASE 50HZ			
FUSE	PIAB	-	-
F1	NONE		
F2	NONE		
F3	NONE		
F4	AM-10		
F5	AM-10		
F6	AM-4		
F7	AM-1		
F8	AM-1		
F9	AM-20		
F10	AM-20		
MOTOR STARTER OL SETTING			

STANDARD  
HIGH ENERGY

440-480 VAC 1 PHASE 60HZ			
FUSE	PIAB	-	-
F1	NONE		
F2	NONE		
F3	NONE		
F4	AM-8		
F5	AM-8		
F6	AM-4		
F7	AM-1		
F8	AM-1		
F9	AM-20		
F10	AM-20		
MOTOR STARTER OL SETTING			

STANDARD  
HIGH ENERGY

LEGEND  
10 & 11 = 240 OR 120 VAC  
23 = 24 VAC  
12 = 24 VAC COMMON  
241 = 24 VDC  
240 = 24 VDC COMMON

CV-TEK

THIS DRAWING IS THE PROPERTY OF CV TEK, INC. AND IS TO BE CONSIDERED CONFIDENTIAL. USE OR REPRODUCTION WITHOUT THE EXPRESS PERMISSION OF THE COMPANY IS STRICTLY PROHIBITED.

TOLERANCES: UNLESS OTHERWISE STATED:  
 FRACTIONAL = ±.015  
 .XX = ±.015  
 .XXX = ±.005  
 DRILLED HOLE: STANDARD S.A.E.

APPROVED MFG: \_\_\_\_\_ APPROVED ENG: \_\_\_\_\_  
 DRAWN BY: R. HILL

TITLE: **MAP-VAC ELECTRICAL SCHEMATIC FUSE GUIDE**

DWG NO.: **MAPVAC-00001-01-REV-** REV: **-**

SCALE: NONE DATE: 01/03/20 SHEET 15 OF 15

PARTS LIST			
ITEM	PART NO.	DESCRIPTION	QTY
1	110519C1	1/4-20 X 3/8 LNG HEX HEAD CAP SCREW, S/S	6
2	122507C1	MK III DISCONNECT SWITCH ASSEMBLY	1
3	123403C1	MK III DISCONNECT ROD	1
4	123404C1	ROTARY DISCONNECT MOUNTING BRACKET	1
5	125706C1	CV-TEK CORR-VAC NAME PLATE	1
6	125784C1	MAPVAC PYLON UPPER DOOR WELDMENT	1
7	125787C1	MAPVAC PYLON LOWER DOOR WELDMENT	1
8	125789C1	MAPVAC PYLON DUCT WELDMENT	1
9	126090C1	SPLIT CORD GRIP INSERT 6-7MM	1
10	126102C1	ICOTEK QVT-20 SPLIT CORD GRIP	1
11	126334C1	PIAB VACUUM POWER COAX PLATE FOR MAP VAC	1
12	126400C1	MAPVAC PYLON WELDMENT	1
13	129809C1	FRL L2R W/ SHUTOFF	1
14	71604701	CORD GRIP 0.250-.375 3/4 90 DEG CE RATED	2
15	71604901	CORD GRIP, .375-.437, 3/4 WOOD	1
16	71605001	CORD GRIP GREY 3/8 NPT STANDARD DIAMETER GROMMET	11
17	71605101 1	.20-.35 DIA. CORD GRIP, 1/2 NPT	2
18	71612701	GROMMET GRAY 1/2-5/8 CORD, 3/4 GRIP	1
19	74203901	1/2 O.D. TUBE UNION EBOW, PLASTIC	1
20	75002801A	CABINET DOOR LATCH, 1/4 TURN FLAT HEAD SLOTTED	5
21	76203201	DOOR VENT COVER, MKIII/MKIV Hi OXYGEN	1
22	79500701	3/8 I.D. GROMMET	17
23	79501501	RUBBER GROMMET 1/2 ID HOLE, 3/32 GROOVE WIDTH, 1.0 OD	1
24	MA020-0098	MAPVAC VALVE ASSEMBLY	1
25	MA101-0002	VACUUM CONTROL PIPING OPTION FOR GAS FLUSH	1
26	MA101-0007	GAS PRESSURE REGULATOR AND PIPING	1
27	MA110-0036	CV HYBRID FUSE PANEL ASSEMBLY	1
28	MA110-0037	MAP-VAC PANEL LAYOUT	1

REVISIONS			
REV	DESCRIPTION	DATE	APPROVED
A	INITIAL RELEASE	2/28/2019	N.B
B	UPDATED BOM TO MATCH INFOR	1/3/2025	GW
C	CHANGED DISCONNECT QTY TO 1	2/17/2025	GW
D	PYLON WELDMENT 125767C1 CHANGED TO 126400C1, add 71612701, 74203901, 91604901	4/7/2025	CI

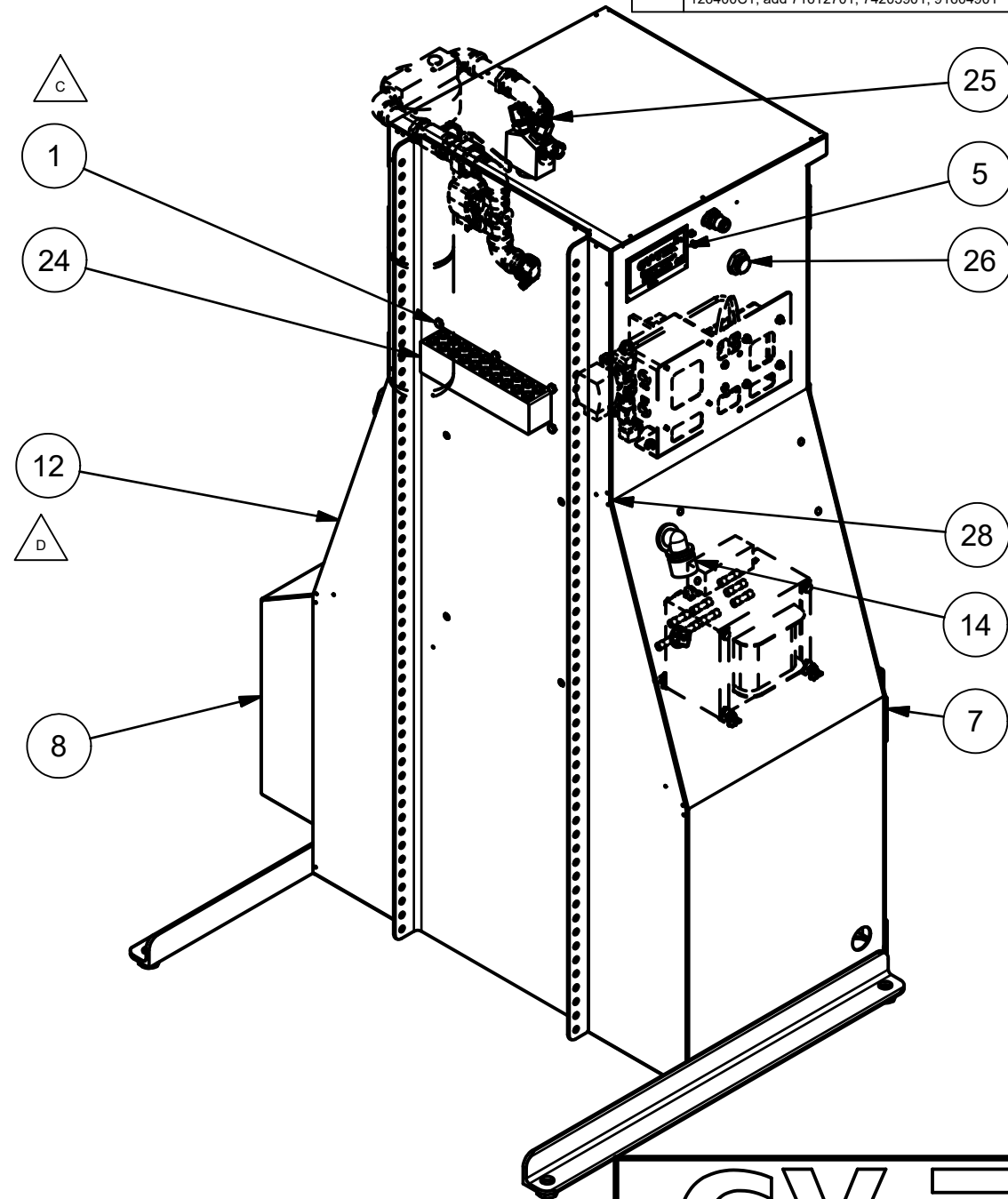

# CV-TEK

THIS DRAWING IS THE PROPERTY OF CV-TEK, INC. AND IS TO BE CONSIDERED CONFIDENTIAL. USE OR REPRODUCTION WITHOUT THE EXPRESS PERMISSION OF THE COMPANY IS STRICTLY PROHIBITED.

TOLERANCES: UNLESS OTHERWISE STATED:  
 FRACTIONAL = ± .015  
 .XX = ± .015  
 .XXX = ± .005  
 .XXXX = ± .0005  
 DRILLED HOLE: STANDARD S.A.E.

APPROVED MFG: \_\_\_\_\_ APPROVED ENG: \_\_\_\_\_

DRAWN BY: TomJr

TITLE:

MAPVAC PYLON ASSEMBLY

DWG NO: MA020-0097

D

SCALE: N/A

DATE: 3/5/2019

SHEET 1 OF 2

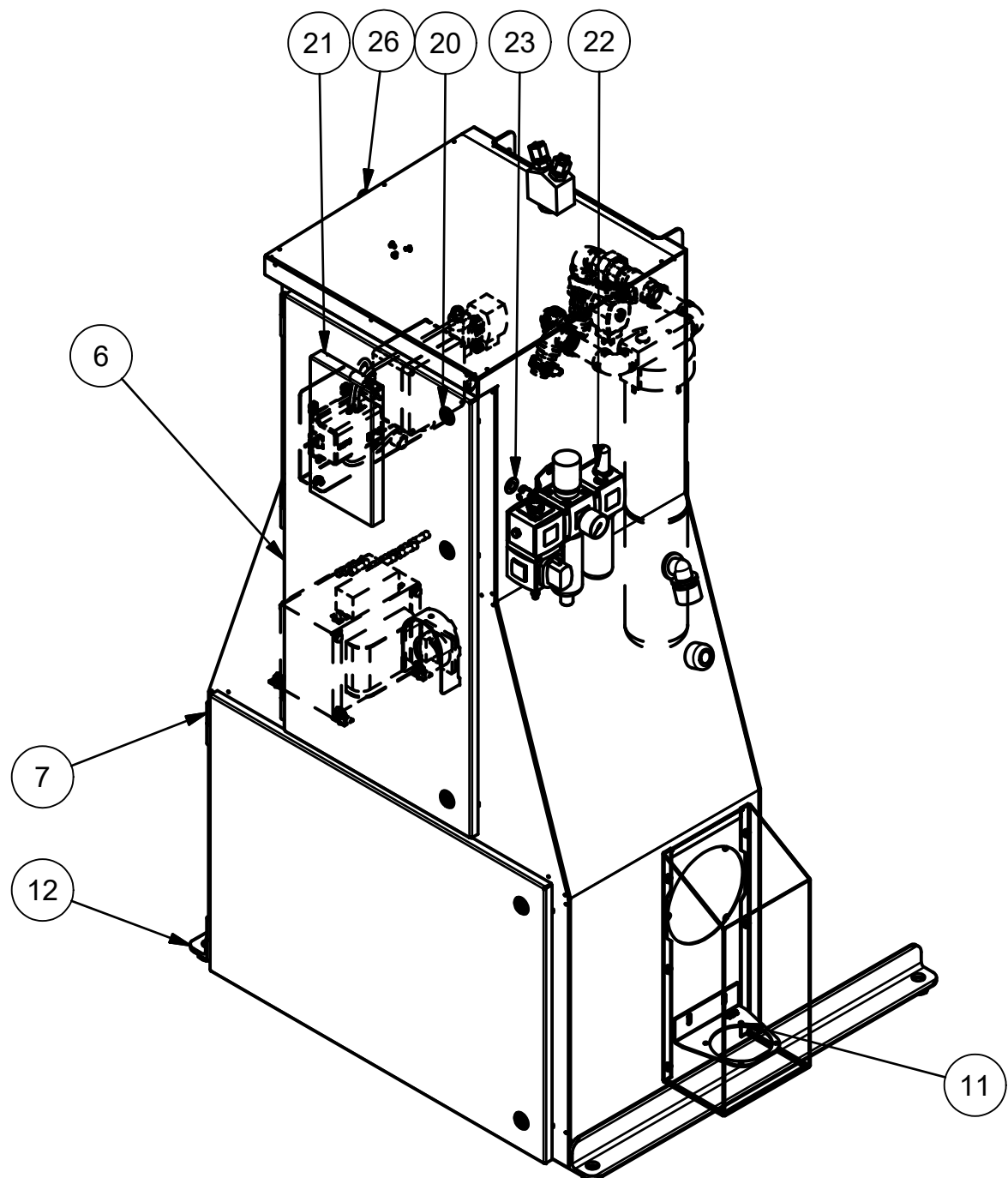
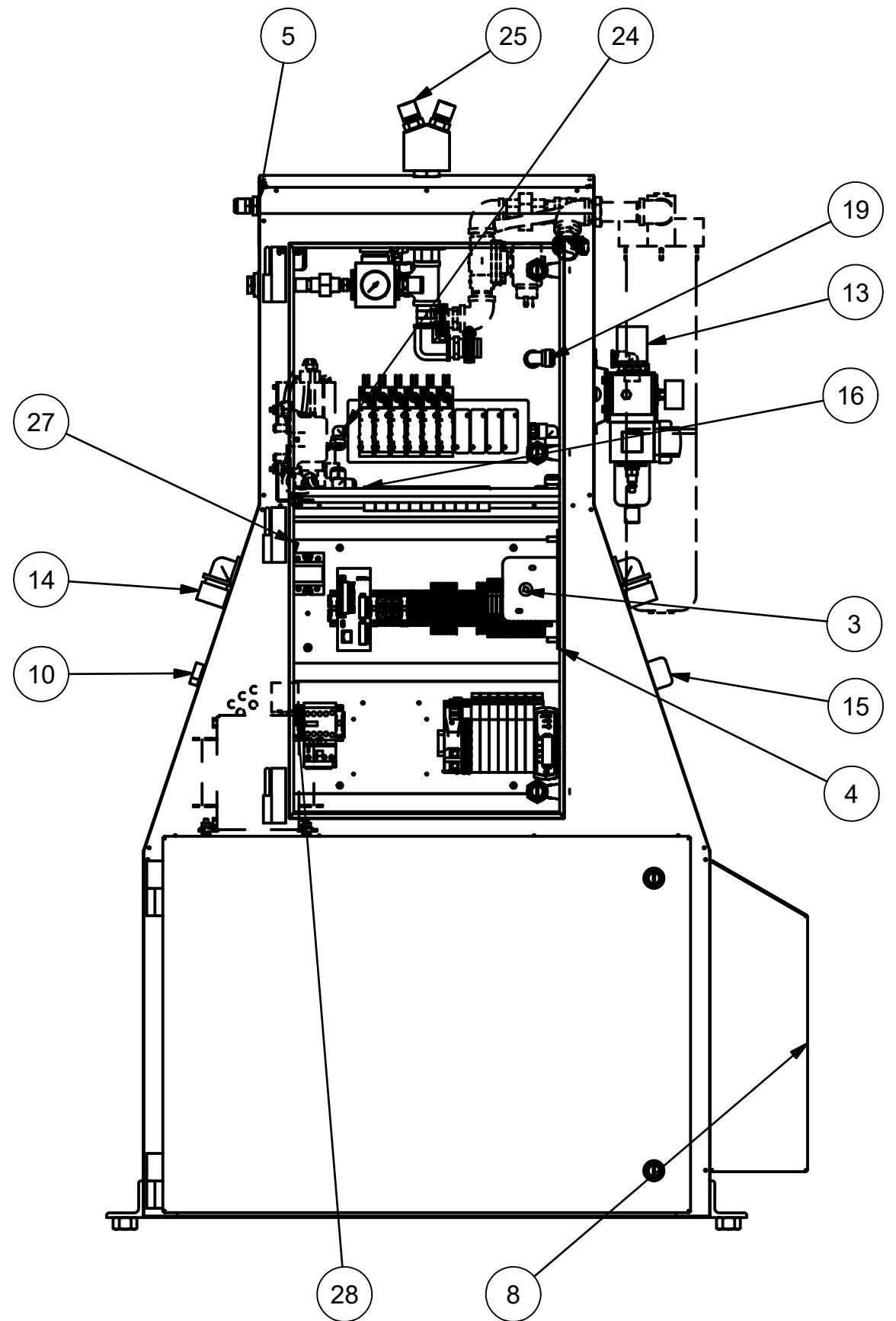

<h1>CV•TEK</h1>	
THIS DRAWING IS THE PROPERTY OF CV•TEK, INC. AND IS TO BE CONSIDERED CONFIDENTIAL. USE OR REPRODUCTION WITHOUT THE EXPRESS PERMISSION OF THE COMPANY IS STRICTLY PROHIBITED.	APPROVED MFG: _____ APPROVED ENG: _____
TOLERANCES: UNLESS OTHERWISE STATED: FRACTIONAL = ± .015 .XX = ± .015 .XXX = ± .005 .XXXX = ± .0005 DRILLED HOLE: STANDARD S.A.E.	DRAWN BY: TomJr
	TITLE: <b>MAPVAC PYLON ASSEMBLY</b>
	DWG NO.: <b>MA020-0097</b>
SCALE: N/A	DATE: 3/5/2019
	SHEET 2 OF 2

D

PARTS LIST			
ITEM	PART NO.	DESCRIPTION	QTY
1	126055C1	MAP VAC, FRAME, HEAD MOUNT, HI-LO HEAD	2
2	126162C1	UPPER CYLINDER MOUNTING FRAME HI-LO HEAD	1
3	75106601	1/4-28 X 1/2 LNG HEX HEAD CAP SCREW, S/S	2
4	73101502	Schrader Bellows joystick control valve, with internal spring	1
5	73200301	CYLINDER, HI-LO HEAD	1
7	73300301	TUBING 1/2 OD NYLON	1
8	73501101	1/4 NPT FLOW CONTROL VALVE	2
9	74204001	3/8 OD TUBE x 3/8 OD PLUG IN ELBOW, PLASTIC	1
10	74204201	3/8 O.D. TUBE X 1/4 NPT FIXED ELBOW, MALE, PLASTIC	2
11	74204301	3/8 OD TUBE x 1/4 NPT FEMALE CONNECTOR, PLASTIC	1
12	74300101	1/4 NPT BREATHER VENT	2
13	74303701	1/4 NPT hex nipple - long	1
14	74304401	1/4 STREET ELBOW, EXTRUDED	1
15	75103401	3/8 FLAT WASHER, 0.875 O.D., 0.06 THCK, S/S	8
16	75104201	3/8-16 HEX NUT, S/S	6
17	75104701	Ø3/8 X 1/2 SOCKET HEAD SHOULDER SCREW, S/S	3
18	75104801	Ø3/8 X 1-3/4 SOCKET HEAD SHOULDER SCREW, S/S	1
19	75105101	1/2-20 HEX JAM NUT, S/S	1
20	75108101	3/8-16 X 1-1/2 LNG HEX HEAD CAP SCREW, S/S	10
21	75108301	3/8-16 X 3 LNG HEX HEAD CAP SCREW, S/S	2
22	75108401	3/8-16 X 1 SOCKET HEAD CAP SCREW, S/S	2
23	75118601	#10-32 HEX NUT, S/S	2
24	75119301H	#10-32 X 1-1/2 PAN HEAD, SLOTTED, S/S	2
25	76107501A	PARALLEL LINK HI-LO HEAD	2
26	76107702A	FRAME, HI-LO HEAD MARK III/IV PYLON MOUNT LEFT HAND	1
27	76107802A	FRAME, HI-LO HEAD MARK III/IV PYLON MOUNT RIGHT HAND	1
28	76107901A	LOWER CYLINDER MOUNTING FRAME HI-LO HEAD	1
29	76108001A	SUPPORT TUBE HI-LO HEAD	1
30	76109001A	STOP ROD TRUNION HI-LO HEAD	1
31	76109101A	CYLINDER ROD TRUNNION, HI-LO HEAD	1
32	76109201A	ROD STOP NUT FOR HI-LO HEAD	1
33	76109701A	JOYSTICK MTG. BRACKET	1
34	76118201A	THREADED ROD FOR HI-LO HEAD	1
35	79100101	BUSHING, BRONZE 3/4 ID X 7/8 OD	8

REVISIONS			
REV	DESCRIPTION	DATE	APPROVED
A	INITIAL RELEASE	6/29/2018	N.B
B	EDITED BOM TO MATCH INFOR	12/6/2024	G.W.

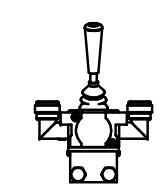
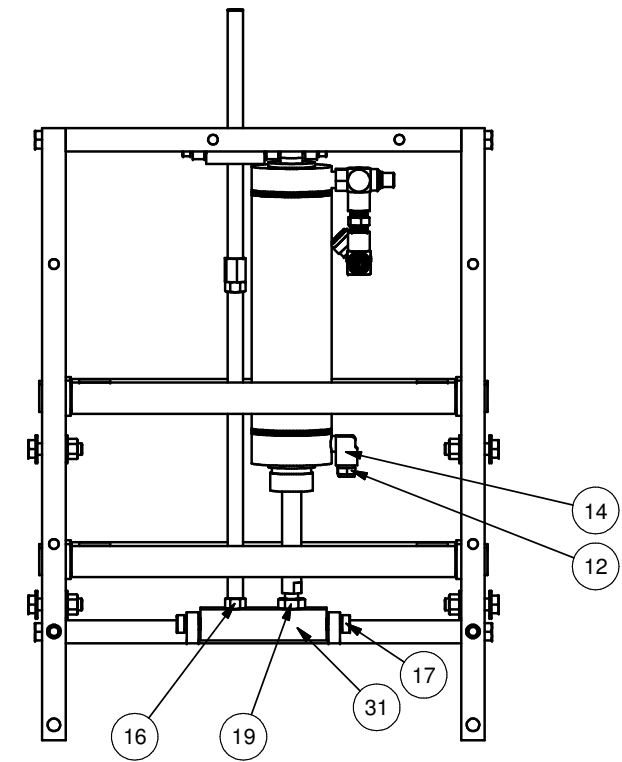
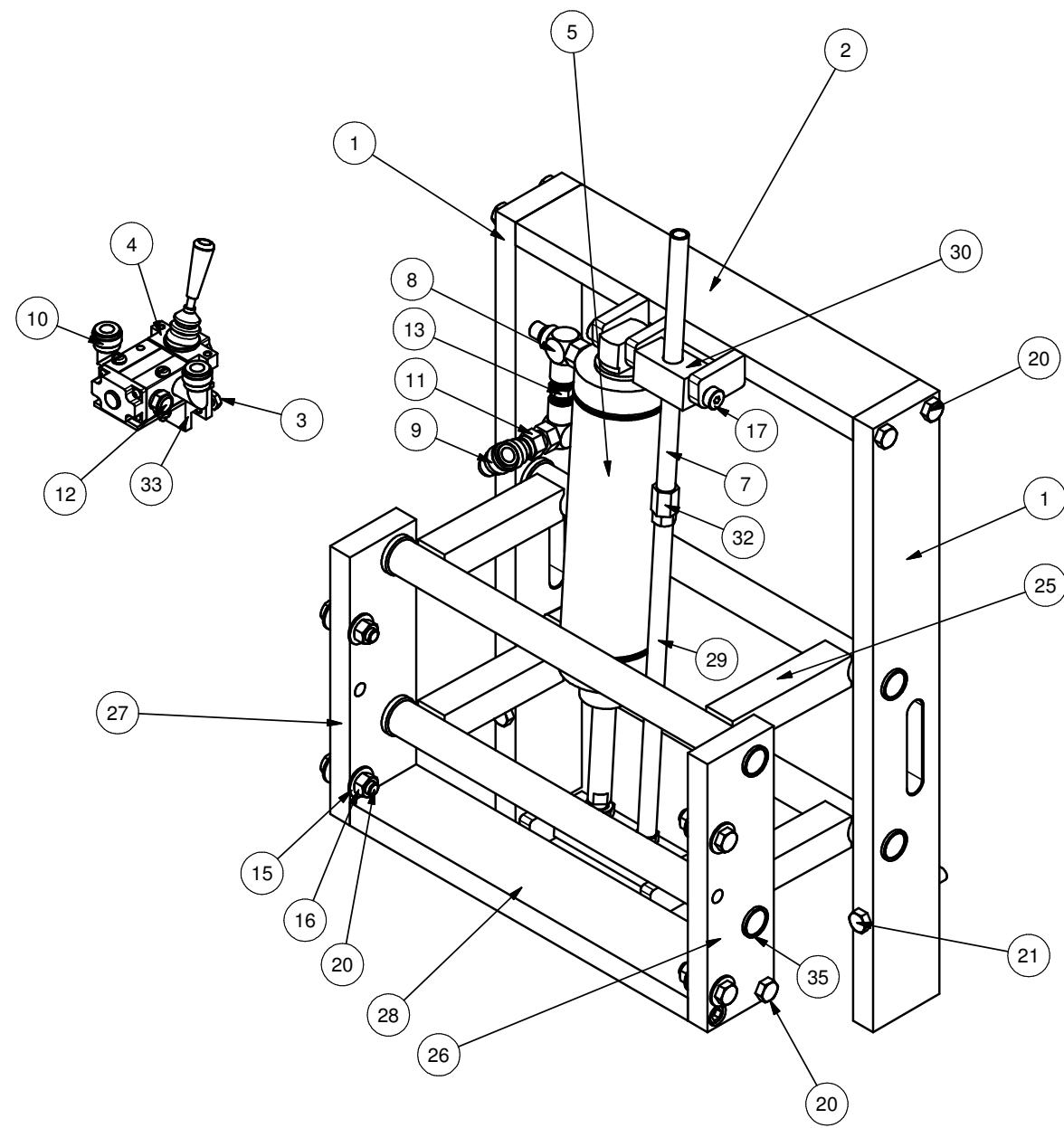

## CV•TEK

THIS DRAWING IS THE PROPERTY OF CV•TEK, INC. AND IS TO BE CONSIDERED CONFIDENTIAL. USE OR REPRODUCTION WITHOUT THE EXPRESS PERMISSION OF THE COMPANY IS STRICTLY PROHIBITED. TOLERANCES UNLESS OTHERWISE STATED:  
 FRACTIONAL - ± .015  
 XX - ± .015  
 XXX - ± .005  
 XXXX - ± .0025  
 DRILL HOLE - STANDARD S.A.E.

APPROVED MFG:	APPROVED ENG:		
DRAWN BY: C.LONITA			
TITLE: MK3 MAP VAC HILO HEAD MOUNT WITH JOYSTICK ASSEMBLY			
DWG NO: MA015-0019			B
SCALE: N/A	DATE:		SHEET 1 OF 1

PARTS LIST			
ITEM	PART NO.	DESCRIPTION	QTY
1	113517C1	Ø1/4 X 1/2 DOWEL PIN, S/S	2
2	120144C1	DRAW LATCH	2
3	120401C1 1	6-32 X 3/8 PAN HEAD SEALING SCREW	4
4	120742C1	3 TIER FEED THROUGH TERMINAL BLOCK; AWG: 24 - 12; W: 6.2MM; GRAY	5
5	120743C1	3 TIER SENSOR TERMINAL BLOCK; AWG: 24 - 12; W: 6.2MM; GRAY	12
6	120747C1	END COVER, L: 65.4 MM, W: 2.2 MM, H: 47.5 MM, COLOR: GRAY	1
7	120751C1	1 TIER PE FEED THROUGH TERMINAL BLOCK; AWG:26-12; W:5.2MM; GRN/YEL	1
8	120752C1	END CLAMP, WIDTH: 9.5 MM, COLOR: GRAY	2
9	122088C1	MK3 DISPLAY BOX HINGE FLAG	2
10	122089C1	MK3 DISPLAY BOX HINGE POST	2
11	122091C1 1	QUARTER TURN DZUZ	2
12	122092C1 1	CLIP ON QUARTER TURN DZUZ PLATE	2
13	122093C1	QUARTER TURN DZUZ RETAINER	2
14	122095C1	QUARTER TURN WEAR WASHER	2
15	122414C2	HSP RESET LEGEND PLATE FOR 22.5MM KNOCKOUT	1
16	125078C1	100 CONVERSION CLEANING LEGEND PLATE	1
17	125749C1	CV HYBRID DISPLAY BOX HMI WINDOW	1
18	125750C1	HYBRID DISPLAY BOX HMI PLATE	1
19	125752C1	MAP VAC DISPLAY BOX DOOR WELDMENT	1
20	125758C1	MAP VAC DISPLAY BOX WELDMENT	1
21	126040C1	MAP VAC BUTTON BOX MOUNTING PLATE WELDMENT	1
22	126045C1	MAP VAC DISPLAY BOX GUARD	1
23	126076C1	B&R POWER PANEL T30 7.0" HMI	1
24	126102C1	ICOTEK QVT-20 SPLIT CORD GRIP	1
25	126512C1	BANNER K50 CAPACITIVE TOUCH BUTTON	2
26	71002701	RAIL, DIN 34 mm WIDE 5 3/4", 16" LONG	1
27	71104402	RED LED AND 3 ACROSS LATCH	1
28	71105201	LEGEND, YELLOW ROUND 60MM	1
29	71105402	E-STOP BUTTON, ILLUMINATED, RED	1
30	71105502	PUSH BUTTON, MOMENTARY, AMBER	1
31	71105802	CONTACT BLOCK, 22 mm 1NC/1NO	3
32	71106102	LATCH, 22mm 3 ACROSS	1
33	71604801	CORD GRIP, .375-.437, 3/4 WOOD	1
34	71605001	CORD GRIP GREY 3/8 NPT STANDARD DIAMETER GROMMET	8
35	71605301	1/2" LOCK NUT	1
36	71607301	3/8 NPT CONDUIT SQUARE LOCKNUT	16
37	74103501	1/4 X 3/8 Reducer, plastic	8
38	74203301	3/8 O.D. TUBE PLUG, PLASTIC, ALKON	7
39	75106001	1/4-20 X 1/2 PAN HEAD, SLOTTED, S/S	2
40	79500701	3/8 I.D. GROMMET	16
41	79501501	RUBBER GROMMET 1/2 ID HOLE, 3/32 GROOVE WIDTH, 1.0 OD	1
42	71612701	GROMMET GRAY 1/2-5/8 CORD, 3/4 GRIP	1

NOT SHOWN: 122806C1 (CABLE; P-LINK RJ45-RJ45; 8m), QTY 1

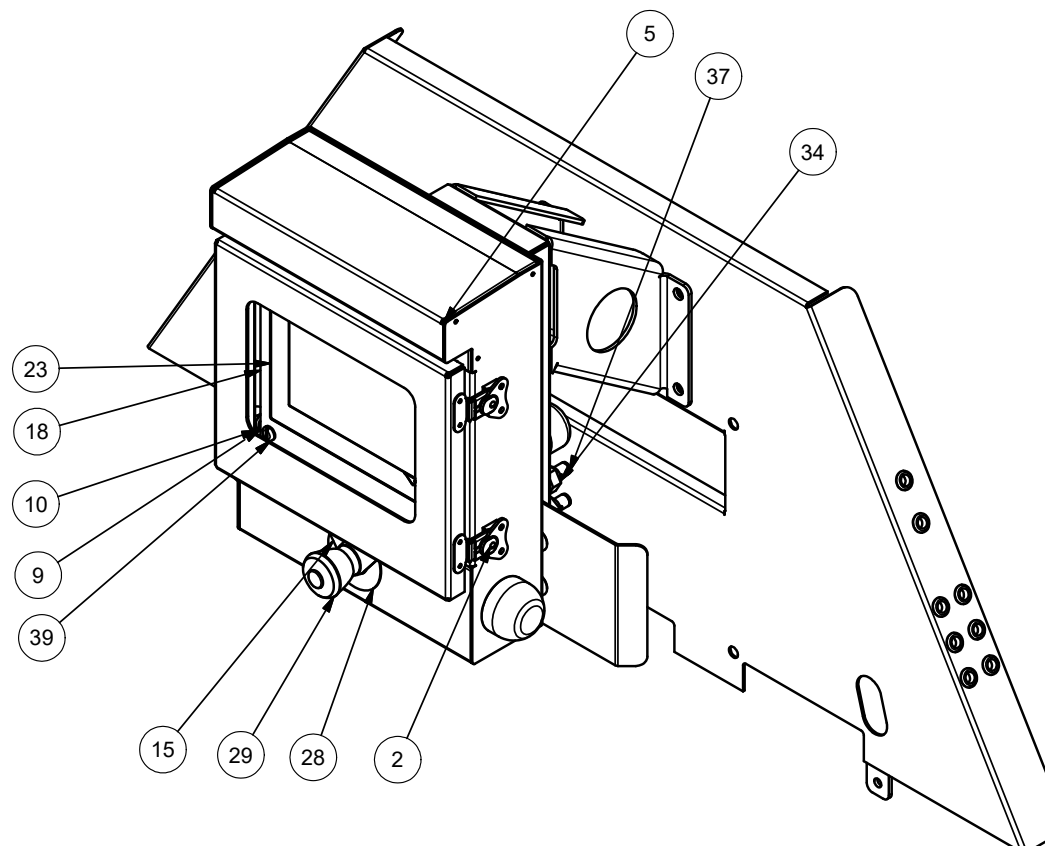
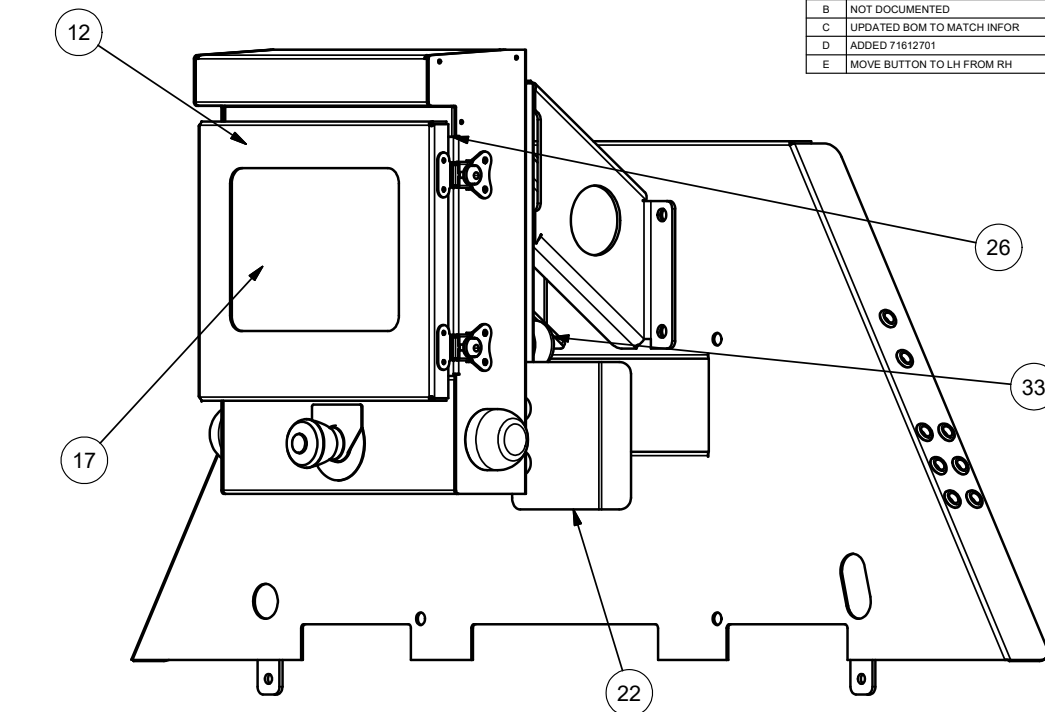
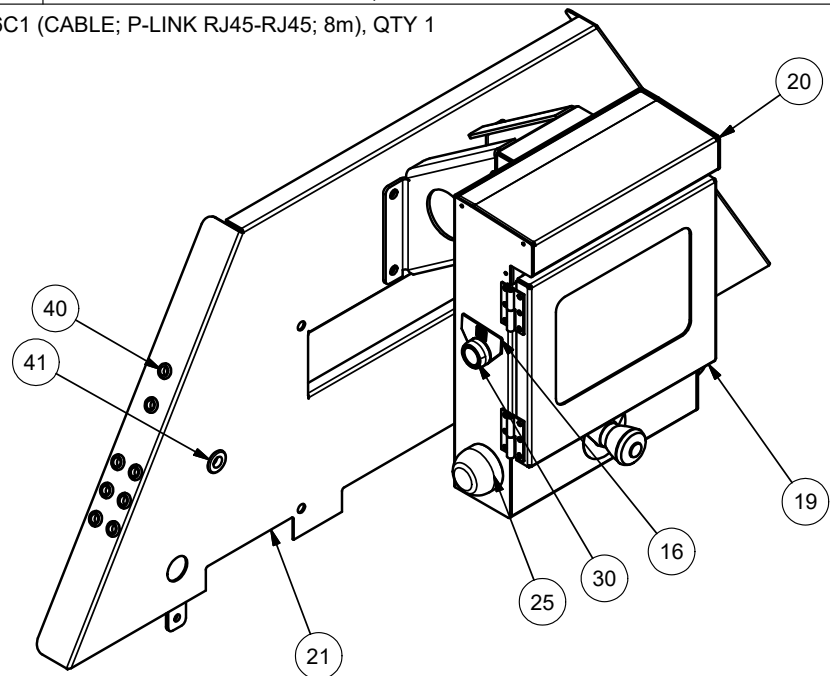

REVISIONS			
REV	DESCRIPTION	DATE	APPROVED
A	DRAWING CREATED	2/28/2019	BB
B	NOT DOCUMENTED	12/15/2010	T.L.
C	UPDATED BOM TO MATCH INFOR	1/3/2025	GW
D	ADDED 71612701	1/30/25	RB
E	MOVE BUTTON TO LH FROM RH	4/10/2025	CI

## CV·TEK

THIS DRAWING IS THE PROPERTY OF CV·TEK, INC. AND IS TO BE CONSIDERED CONFIDENTIAL. USE OR REPRODUCTION WITHOUT THE EXPRESS PERMISSION OF THE COMPANY IS STRICTLY PROHIBITED.

TOLERANCES UNLESS OTHERWISE STATED:  
 FRACTIONAL = ± .015  
 XX = ± .015  
 XXX = ± .005  
 XXXX = ± .0005  
 UNLESS OTHERWISE SPECIFIED

APPROVED MFG:	APPROVED ENG:
DRAWN BY: Tom J	
TITLE: <b>MAP-VAC DISPLAY BOX ASSEMBLY</b>	
DWG NO: <b>MA025-0019</b>	E
SCALE: N/A	DATE:
SHEET 1 OF 3	

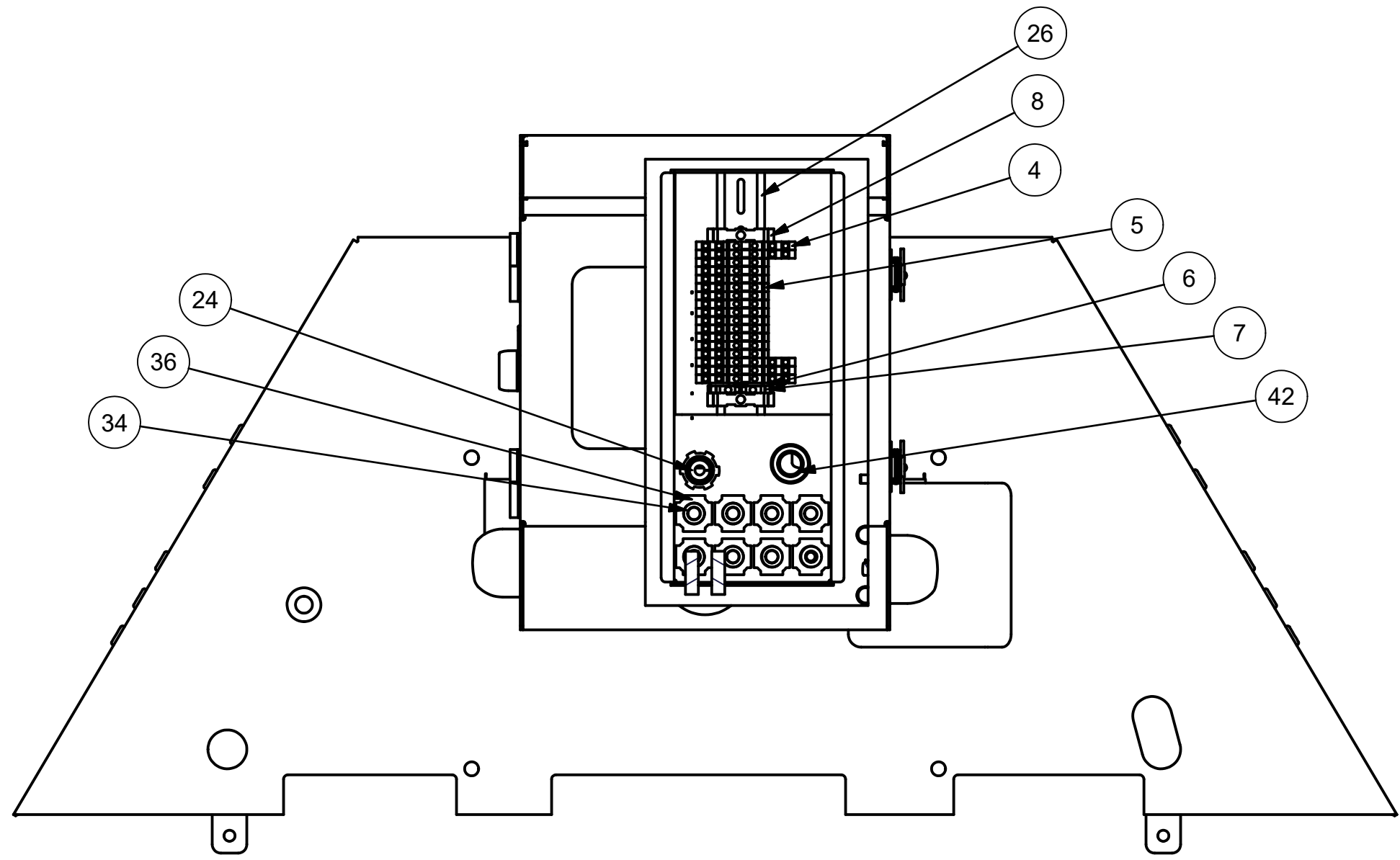

# CV•TEK

THIS DRAWING IS THE PROPERTY OF CV•TEK, INC. AND IS TO BE CONSIDERED CONFIDENTIAL. USE OR REPRODUCTION WITHOUT THE EXPRESS PERMISSION OF THE COMPANY IS STRICTLY PROHIBITED.

TOLERANCES: UNLESS OTHERWISE STATED:  
 FRACTIONAL = ± .015  
 .XX = ± .015  
 .XXX = ± .005  
 .XXXX = ± .0005  
 DRILLED HOLE: STANDARD S.A.F.

APPROVED MFG:	APPROVED ENG:
DRAWN BY: TomJr	
TITLE: <b>MAP-VAC DISPLAY BOX ASSEMBLY</b>	
DWG NO: <b>MA025-0019</b>	<b>E</b>
SCALE: N/A	DATE: SHEET 2 OF 3

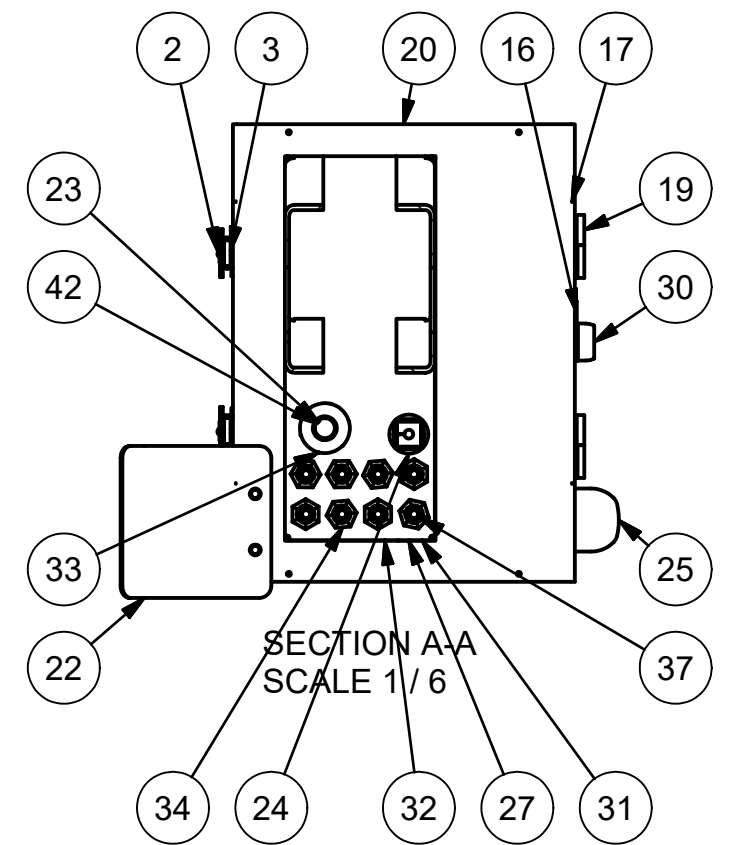
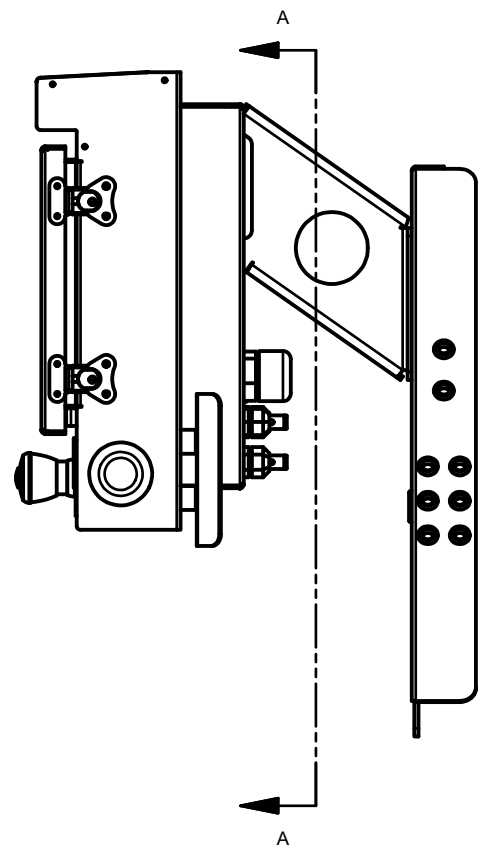
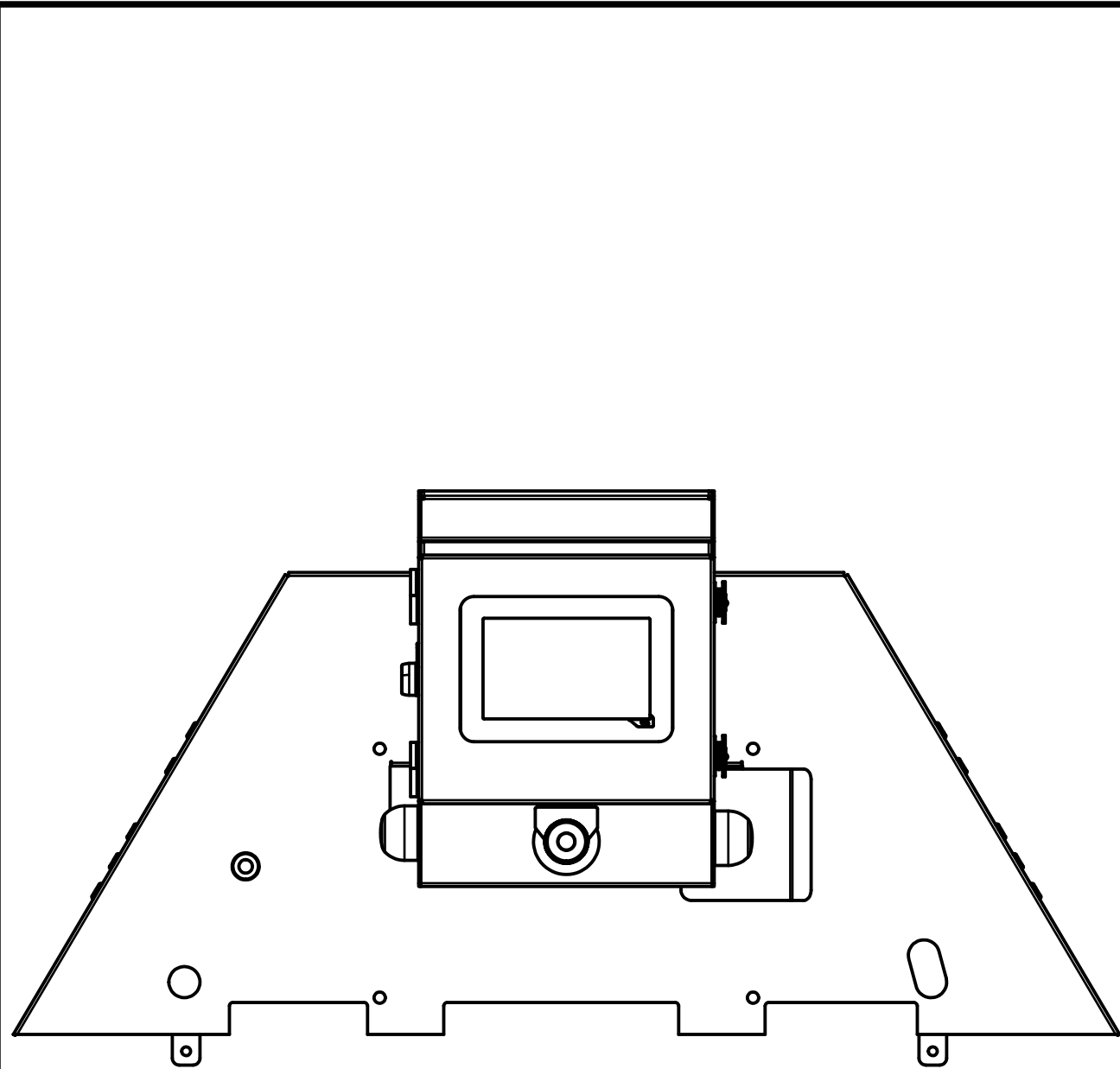

<h1>CV·TEK</h1>	
THIS DRAWING IS THE PROPERTY OF CV·TEK, INC. AND IS TO BE CONSIDERED CONFIDENTIAL. USE OR REPRODUCTION WITHOUT THE EXPRESS PERMISSION OF THE COMPANY IS STRICTLY PROHIBITED.	APPROVED MFG: _____ APPROVED ENG: _____
TOLERANCES: UNLESS OTHERWISE STATED: FRACTIONAL = ± .015 .XX = ± .015 .XXX = ± .005 .XXXX = ± .0005 DRILLED HOLE: STANDARD S.A.E.	DRAWN BY: TomJr
	TITLE: <b>MAP-VAC DISPLAY BOX ASSEMBLY</b>
	DWG NO.: <b>MA025-0019</b>
SCALE: N/A	DATE: _____ SHEET 3 OF 3

REVISIONS			
REV	DESCRIPTION	DATE	APPROVED
A	INITIAL CREATION	11/22/2019	MTEKCORP\lbbange
B	NOT DOCUMENTED	N/A	N/A
C	EDITED BOM TO MATCH INFOR	12/02/2024	GW
D	ADD FITTINGS	4/8/2025	CI

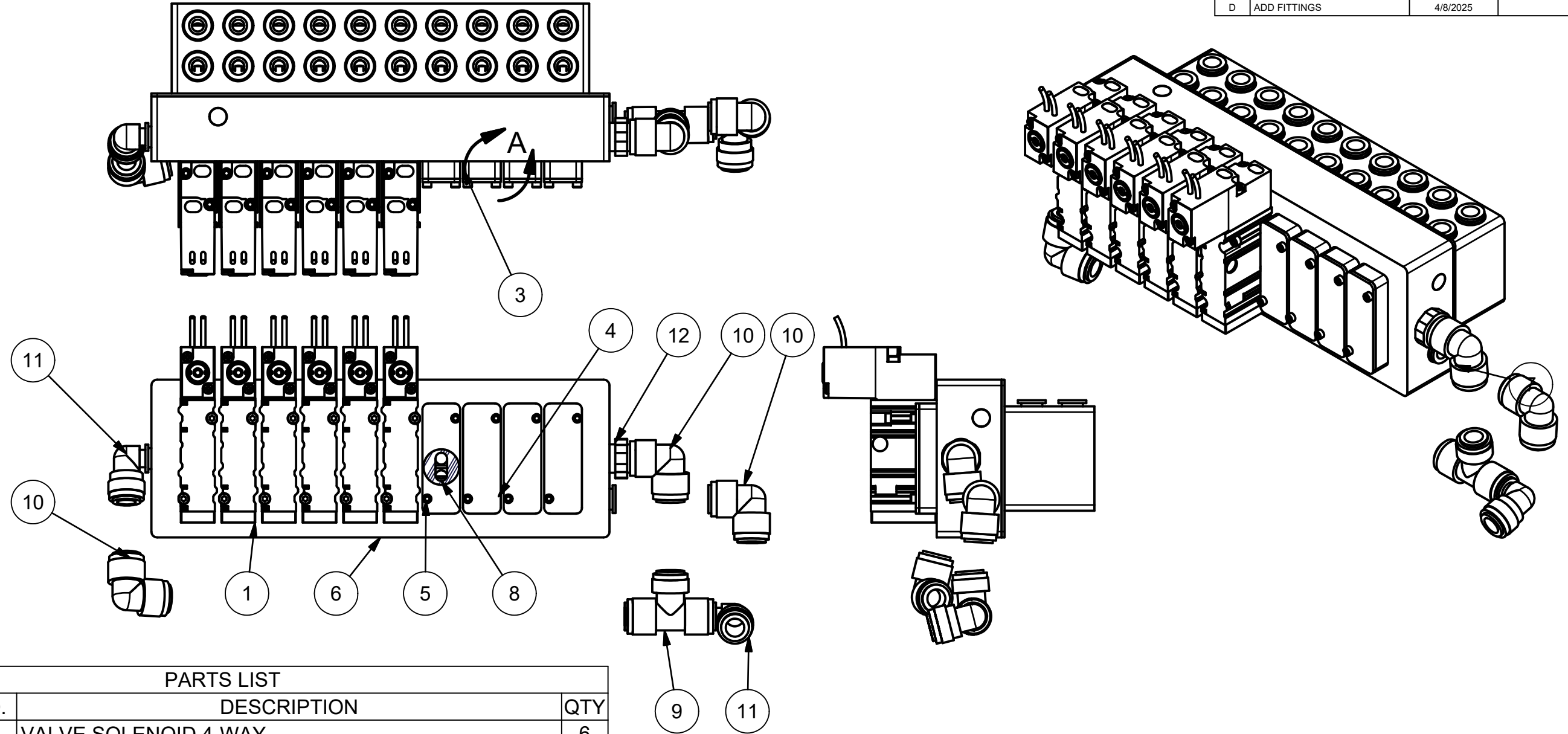

PARTS LIST			
ITEM	PART NO.	DESCRIPTION	QTY
1	114224C3	VALVE SOLENOID 4-WAY	6
2	125307C1	400 SERIES VALVE GASKET	4
3	125352C1	VALVE BLOCKER PLATE	3
4	125361C1	MHSP VALVE BLOCK BLANK PLATE	4
5	125512C1	#4-40 X 3/4 SOCKET HEAD CAP SCREW, S/S	8
6	125791C1	MAPVAC VALVE MANIFOLD COMPLETE	1
7	125793C1	MAPVAC VALVE GASKET	1
8	125839C1	VALVE BLOCKER PLATE PASS THRU	1
9	74203501	3/8 OD TUBE, UNION TEE, PLASTIC	1
10	74203801	3/8 O.D. TUBE, UNION ELBOW	3
11	74204001	3/8 OD TUBE x 3/8 OD PLUG IN ELBOW, PLASTIC	2
12	74204701	3/8 O.D. TUBE X 3/8 NPT STEM ADAPTER, PLASTIC	1

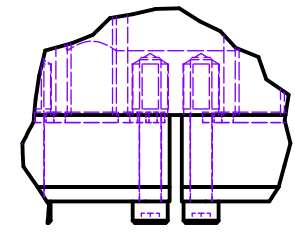

DETAIL A  
SCALE 1 : 1

# CV•TEK

THIS DRAWING IS THE PROPERTY OF CV•TEK, INC. AND IS TO BE CONSIDERED CONFIDENTIAL. USE OR REPRODUCTION WITHOUT THE EXPRESS PERMISSION OF THE COMPANY IS STRICTLY PROHIBITED.

TOLERANCES: UNLESS OTHERWISE STATED:  
 FRACTIONAL = ± .015  
 .XX = ± .015  
 .XXX = ± .005  
 .XXXX = ± .0005  
 DRILLED HOLE - STANDARD S.A.E.

APPROVED MFG:	APPROVED ENG:
DRAWN BY: TomJr	TITLE:
MAPVAC VALVE ASSEMBLY	
DWG NO: MA020-0098	D
SCALE: N/A	DATE: 3/6/2019
SHEET 1 OF 1	

REVISIONS			
REV	DESCRIPTION	DATE	APPROVED
A	INITIAL RELEASE	3/3/2021	N.B

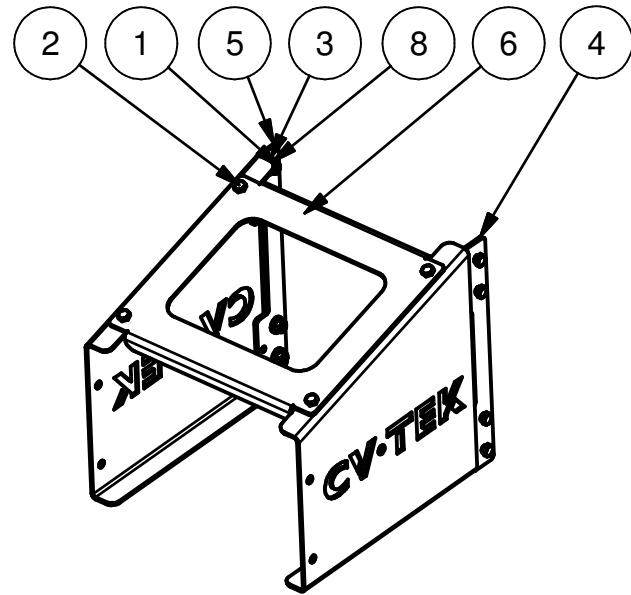

PARTS LIST			
ITEM	PART NO.	DESCRIPTION	QTY
1	108690C1	3/8-16 X 7/8 LNG HEX HEAD CAP SCREW, S/S	8
2	108733C1	3/8-16 UNC x 3/4 LG. - HHCS	8
3	108745C1	3/8 FLAT WASHER, 0.875 O.D., 0.14 THCK, S/S	12
4	128982C1	SPACER WELDMENT, 14" RH MAP-VAC HI-LO HEAD	1
5	128983C1	SPACER WELDMENT, 14" LH MAP-VAC HI-LO HEAD	1
6	128998C1	MAP-VAC BULK BIN HEAD EXTENSION CROSS BRACE	1
7	751157C1	5/8 Flat washer 18-8 stainless steel	8
8	75104201	3/8-16 HEX NUT, S/S	12
9	75104501	3/4-10 HEX NUT, S/S	4
10	75116101	5/8-11 X 3-3/4 LNG HEX HEAD CAP SCREW, S/S	4
11	75116701	3/8-16 ACORN NUT, S/S	4
12	75116901	5/8-11 HEX NUT, S/S	4
13	76204601A	BUMPER, MK III BULK BIN	1
14	76209201	MKIII LEG FRAME BULK BIN	1
15	79201902	CASTER; 5 INCH GREY WHEEL 3/4-10 X 2 INCH STEM WHEEL & SWIVEL LOCK	4
16	86205700	MKIII BULK BIN LEG ANGLE WELDMENT	2

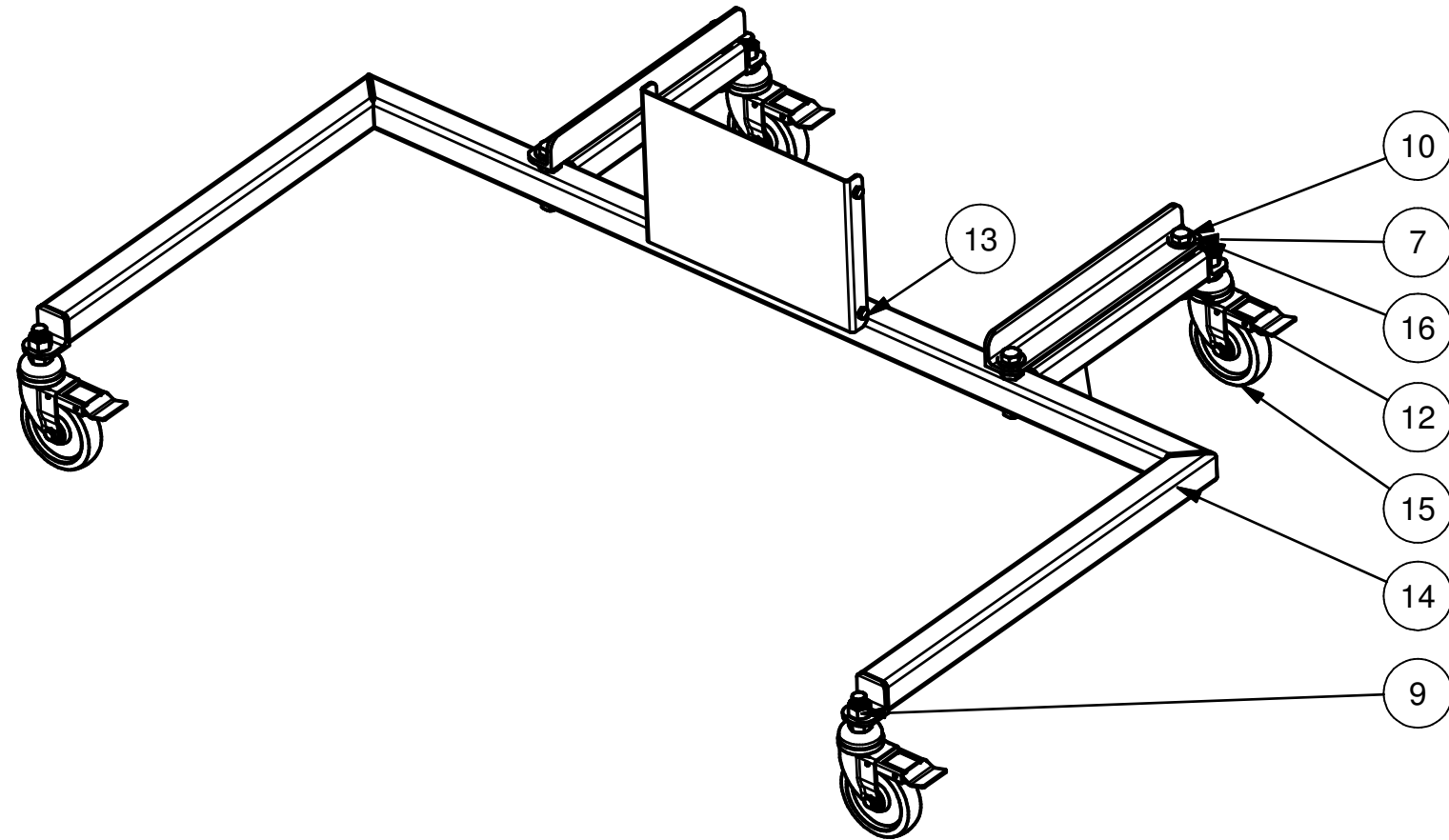

<h1>CV-TEK</h1>	
THIS DRAWING IS THE PROPERTY OF CV-TEK, INC. AND IS TO BE CONSIDERED CONFIDENTIAL. USE OR REPRODUCTION WITHOUT THE EXPRESS PERMISSION OF THE COMPANY IS STRICTLY PROHIBITED.	APPROVED MFG: _____ APPROVED ENG: _____
TOLERANCES: UNLESS OTHERWISE STATED: FRACTIONAL = ± .015 XX = ± .015 .XXX = ± .005 XXXX = ± .0005 DRILLED HOLE: STANDARD S.A.E.	DRAWN BY: mevens
	TITLE: <b>MAP-VAC BULK BIN CHASSIS, ROLL AROUND</b>
	DWG NO.: <b>MA081-0006</b> <span style="float: right;">A</span>
SCALE: N/A	DATE: _____ SHEET 1 OF 1

PARTS LIST			
ITEM	PART NO.	DESCRIPTION	QTY
1	108240C1	1/4-20 X 1-1/4 LNG HEX HEAD CAP SCREW, S/S	2
2	108586C1	1/4-20 X 5/8 LNG HEX HEAD CAP SCREW, S/S	4
3	110516C1	1/4 M TUBE O.D. X 1/4 TUBE PLUG IN ELBOW	1
4	110519C1	1/4-20 X 3/8 LNG HEX HEAD CAP SCREW, S/S	2
5	113034C1	CUTOFF CYLINDER, ANODIZED ALUMINUM END CAPS	1
6	120498C1	SCHNEIDER INDUCTIVE PROXIMITY SWITCH	2
7	120502C1	I/O CABLE 5M STRAIGHT 5 PIN M12 IP67	2
8	123565C1	1/2 ID TOP HAT BUSHING.	4
9	124010C1	Ø7/8 RETAINING RING,INT, S/S	4
10	125194C1	3/8 ID x 1/2 LONG FLANGED BRONZE BUSHING	1
11	125655C1	CV BAG STRECHER CROSS ROD	2
12	125656C1	CV BAG STRECHER MOUNT BRACKET LH	1
13	125657C1	CV BAG STRECHER MOUNT BRACKET RH	1
14	125665C1	CV BAG STRECHER SLIDE BLOCK	1
15	125666C1	CV BAG STRECHER CYLINDER CLEVIS	1
16	125667C1	CV BAG STRECHER CLAMP BLOCK	1
17	125668C1	CV BAG STRECHER CLAMP PLATE	1
18	125669C1	CV BAG STRECHER THUMB SCREW	2
19	125673C1	1-1/16" BORE x 3" STROKE CYLINDER	1
20	125700C1	CV BAG STRETCHER GUIDE BLOCK COMPLETE	1
21	125703C1	CV BAG STRETCHER CYLINDER PLATE	1
22	125844C1	MAP VAC FINGER CYLINDER STOP	1
23	125847C1	MAP VAC FINGER CYLINDER GUIDE WELDMENT	1
24	125850C1	MAP VAC BAG STRECHER PUSH PLATE WELDMENT	1
25	73501702	Flow control, 1/8 NPT	4
26	75103301	1/4 FLAT WASHER, 0.625 O.D., 0.06 THCK, S/S	4
27	75104401	5/8-18 HEX JAM NUT, S/S	1
28	75107501	5/16-18 X 1/2 LNG HEX HEAD CAP SCREW, S/S	4
29	75110201	1/4 FLAT WASHER, 0.500 O.D., 0.07 THCK, S/S	2
30	75112401	5/16-24 HEX JAM NUT, S/S	2

NOT SHOWN: 126048C1 (SAFETY PROX M12), QTY 1

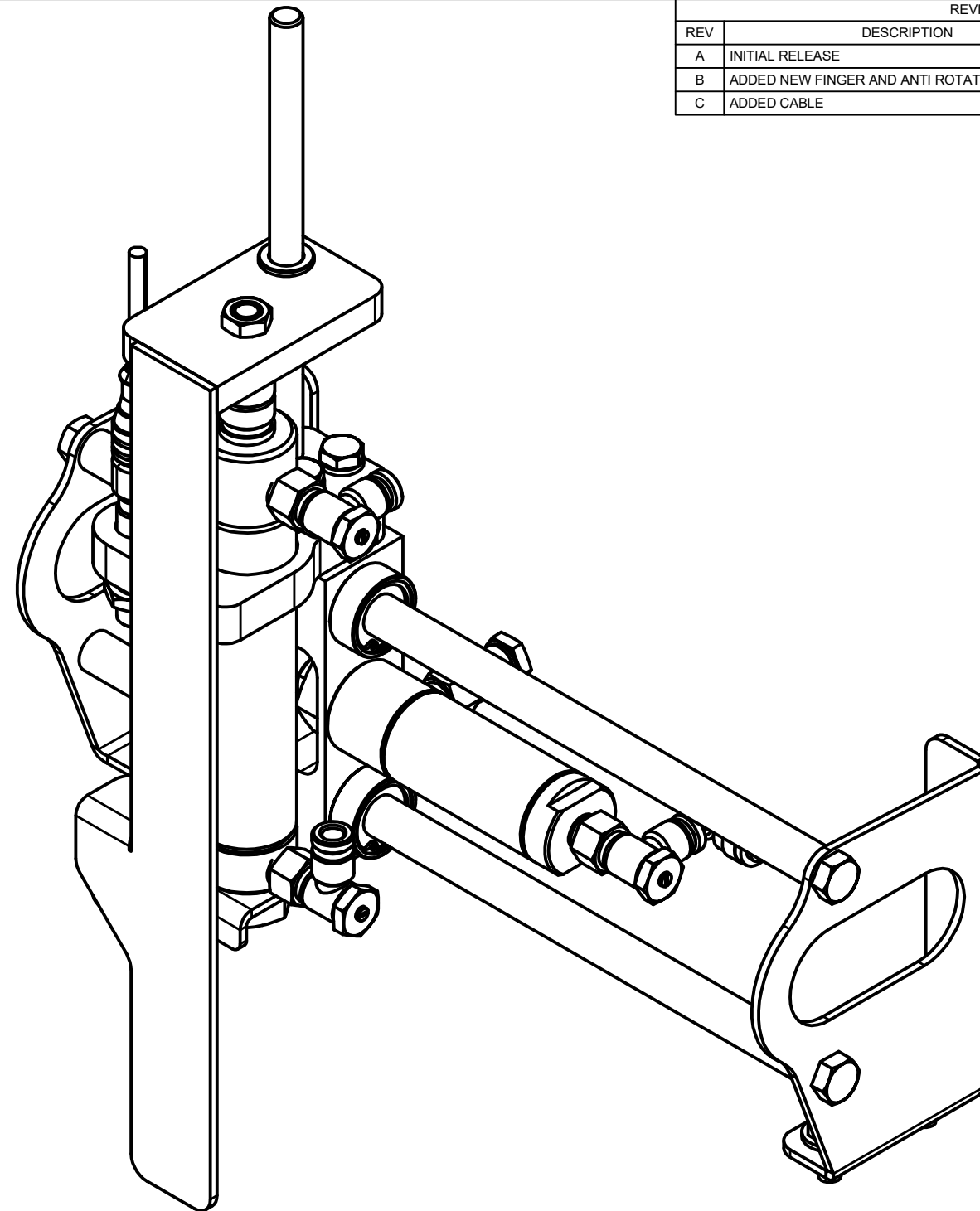

REVISIONS			
REV	DESCRIPTION	DATE	APPROVED
A	INITIAL RELEASE		N.B
B	ADDED NEW FINGER AND ANTI ROTATION ROD	2/20/2019	N.B.
C	ADDED CABLE	3/20/2024	JRS

# CV•TEK

THIS DRAWING IS THE PROPERTY OF CV•TEK, INC. AND IS TO BE CONSIDERED CONFIDENTIAL. USE OR REPRODUCTION WITHOUT THE EXPRESS PERMISSION OF THE COMPANY IS STRICTLY PROHIBITED.

TOLERANCES: UNLESS OTHERWISE STATED:  
 FRACTIONAL = ± .015  
 XX = ± .015  
 .XXX = ± .005  
 .XXXX = ± .0005  
 DRILLED HOLE: STANDARD S.A.F.

APPROVED MFG: \_\_\_\_\_ APPROVED ENG: \_\_\_\_\_

DRAWN BY: TomJr

TITLE: MAP VAC BAG STRECHER ASSEMBLY RH

DWG NO: MA261-0008

SCALE: N/A

DATE: 1/15/2019

SHEET 1 OF 2

C

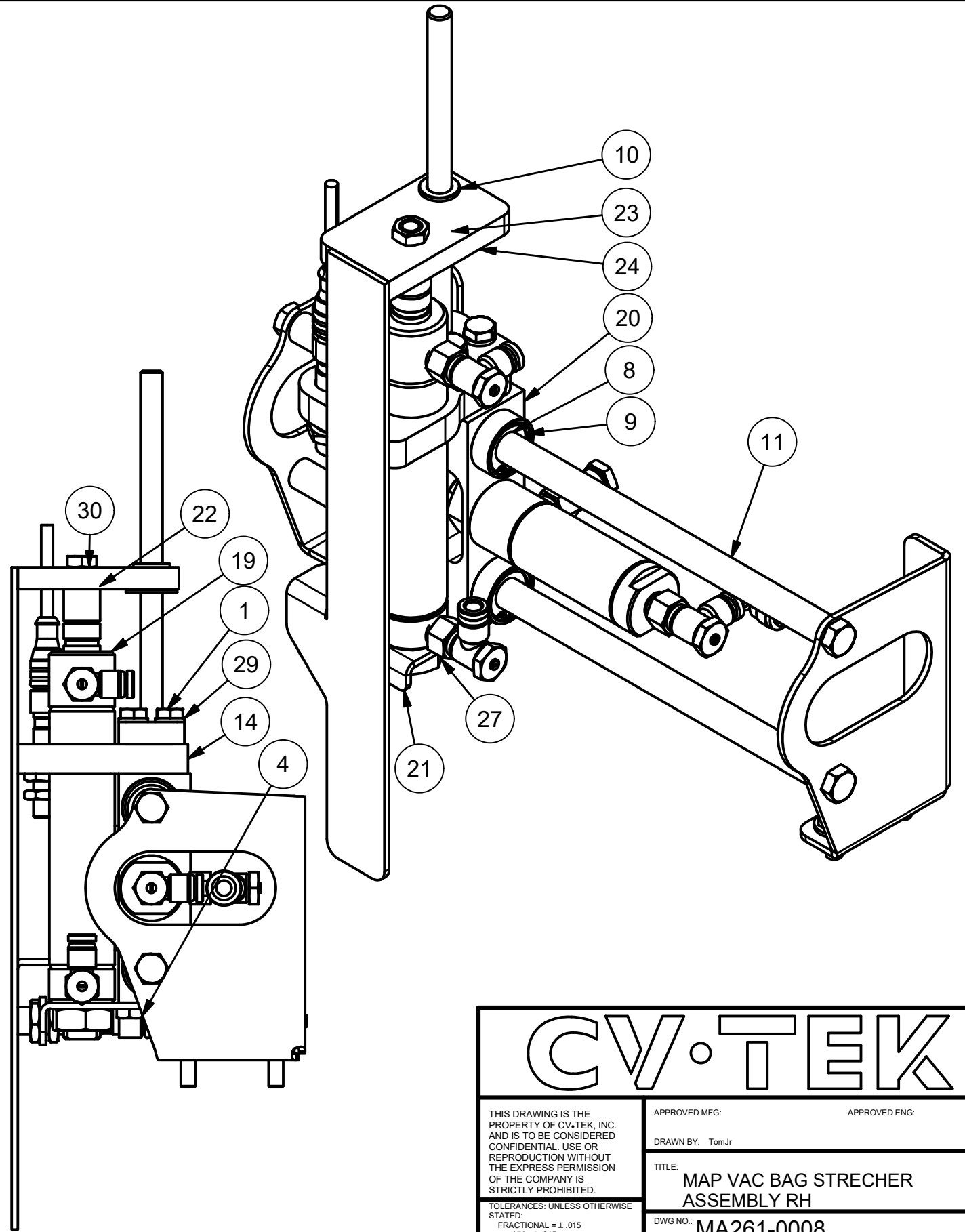
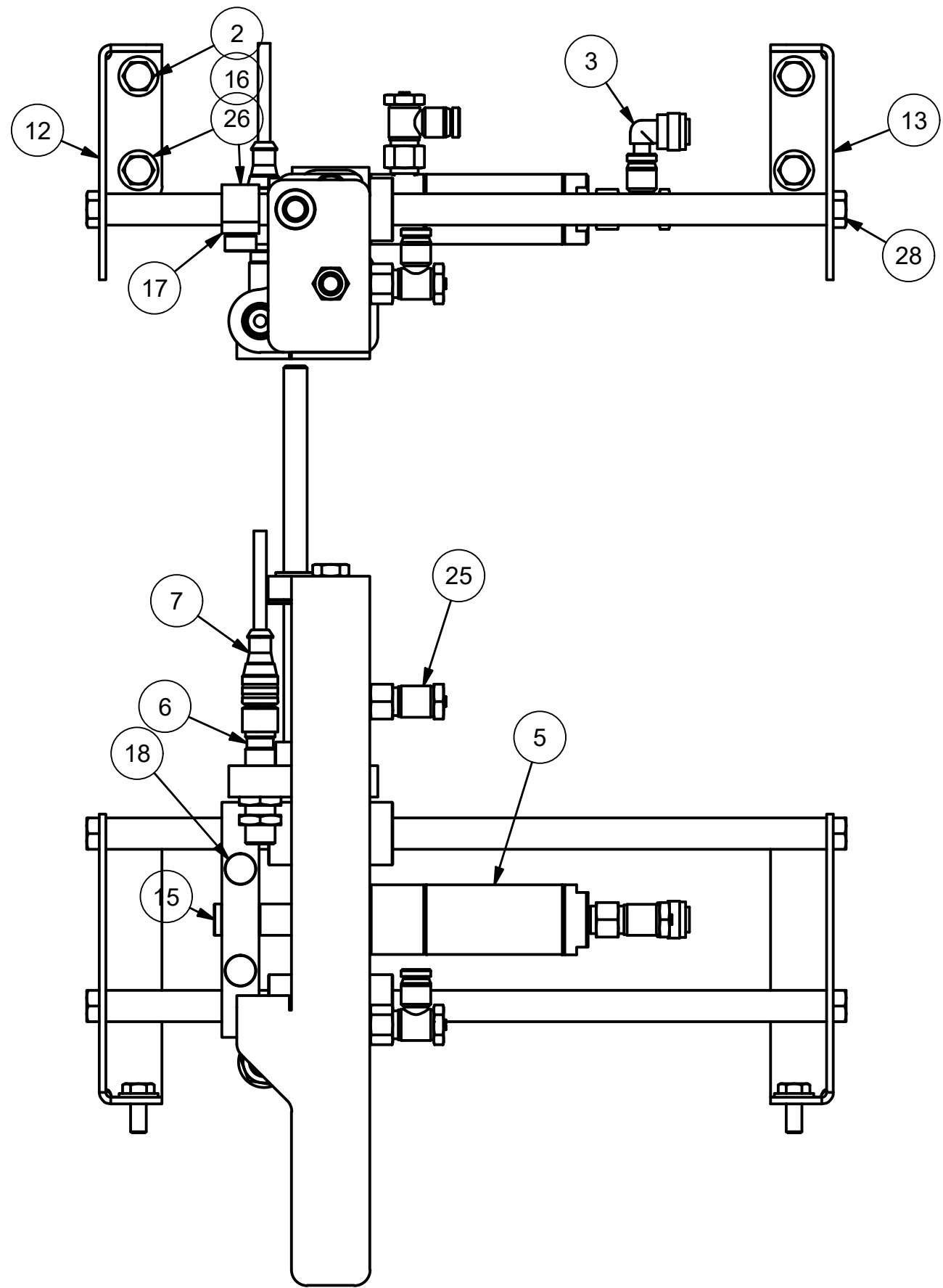

<h1>CV•TEK</h1>	
THIS DRAWING IS THE PROPERTY OF CV•TEK, INC. AND IS TO BE CONSIDERED CONFIDENTIAL. USE OR REPRODUCTION WITHOUT THE EXPRESS PERMISSION OF THE COMPANY IS STRICTLY PROHIBITED.	APPROVED MFG: _____ APPROVED ENG: _____
TOLERANCES: UNLESS OTHERWISE STATED: FRACTIONAL = ± .015 XX = ± .015 XXX = ± .005 .XXXX = ± .0005 DRILLED HOLE: STANDARD S.A.F.	DRAWN BY: TomJr
	TITLE: <b>MAP VAC BAG STRECHER ASSEMBLY RH</b>
	DWG NO.: <b>MA261-0008</b>
SCALE: N/A	DATE: 1/15/2019
	SHEET 2 OF 2

PARTS LIST			
ITEM	PART NO.	DESCRIPTION	QTY
1	108586C1	1/4-20 X 5/8 LNG HEX HEAD CAP SCREW, S/S	4
2	110516C1	1/4 M TUBE O.D. X 1/4 TUBE PLUG IN ELBOW	1
3	110519C1	1/4-20 X 3/8 LNG HEX HEAD CAP SCREW, S/S	2
4	113034C1	CUTOFF CYLINDER, ANODIZED ALUMINUM END CAPS	1
5	120498C1	SCHNEIDER INDUCTIVE PROXIMITY SWITCH	2
6	120502C1	I/O CABLE 5M STRAIGHT 5 PIN M12 IP67	2
7	123565C1	1/2 ID TOP HAT BUSHING.	4
8	124010C1	Ø7/8 RETAINING RING,INT, S/S	4
9	125194C1	3/8 ID x 1/2 LONG FLANGED BRONZE BUSHING	1
10	125655C1	CV BAG STRECHER CROSS ROD	2
11	125656C1	CV BAG STRECHER MOUNT BRACKET LH	1
12	125657C1	CV BAG STRECHER MOUNT BRACKET RH	1
13	125665C1	CV BAG STRECHER SLIDE BLOCK	1
14	125666C1	CV BAG STRECHER CYLINDER CLEVIS	1
15	125667C1	CV BAG STRECHER CLAMP BLOCK	1
16	125668C1	CV BAG STRECHER CLAMP PLATE	1
17	125669C1	CV BAG STRECHER THUMB SCREW	2
18	125673C1	1-1/16" BORE x 3" STROKE CYLINDER	1
19	125700C1	CV BAG STRETCHER GUIDE BLOCK COMPLETE	1
20	125703C1	CV BAG STRETCHER CYLINDER PLATE	1
21	125844C1	MAP VAC FINGER CYLINDER STOP	1
22	125847C1	MAP VAC FINGER CYLINDER GUIDE WELDMENT	1
23	125850C1	MAP VAC BAG STRECHER PUSH PLATE WELDMENT	1
24	73501702	Flow control, 1/8 NPT	4
25	75103301	1/4 FLAT WASHER, 0.625 O.D., 0.06 THCK, S/S	4
26	75104401	5/8-18 HEX JAM NUT, S/S	1
27	75107501	5/16-18 X 1/2 LNG HEX HEAD CAP SCREW, S/S	4
28	75109601	1/4-20 X 7/8 LNG HEX HEAD CAP SCREW, S/S	2
29	75110201	1/4 FLAT WASHER, 0.500 O.D., 0.07 THCK, S/S	2
30	75112401	5/16-24 HEX JAM NUT, S/S	2

NOT SHOWN: 126048C1 (SAFETY PROX M12), QTY 1

REVISIONS			
REV	DESCRIPTION	DATE	APPROVED
A	INITIAL RELEASE		N.B

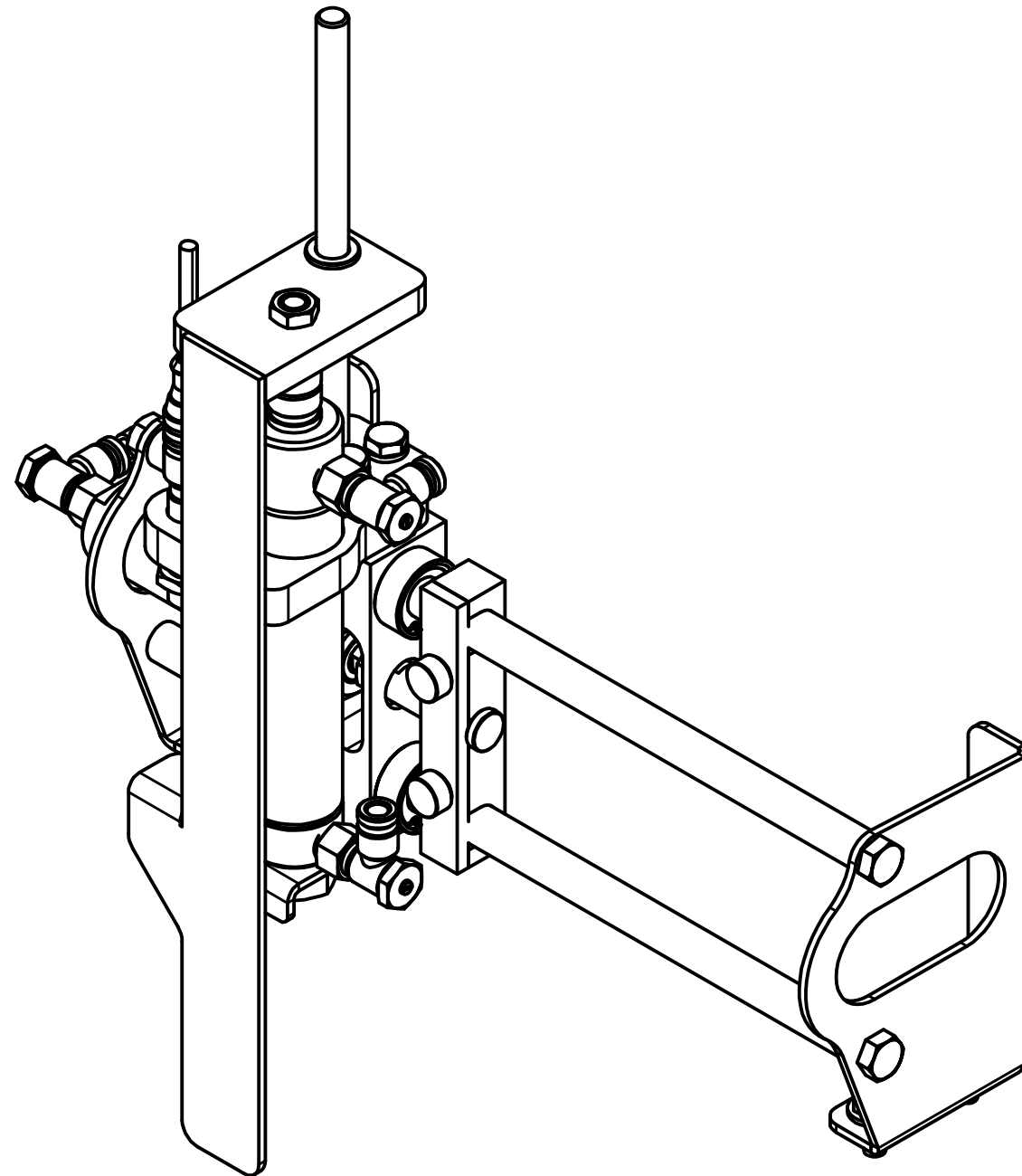

# CV•TEK

THIS DRAWING IS THE PROPERTY OF CV•TEK, INC. AND IS TO BE CONSIDERED CONFIDENTIAL. USE OR REPRODUCTION WITHOUT THE EXPRESS PERMISSION OF THE COMPANY IS STRICTLY PROHIBITED.

TOLERANCES: UNLESS OTHERWISE STATED:  
 FRACTIONAL = ± .015  
 XX = ± .015  
 .XXX = ± .005  
 .XXXX = ± .0005  
 DRILLED HOLE: STANDARD S.A.F.

APPROVED MFG: \_\_\_\_\_ APPROVED ENG: \_\_\_\_\_

DRAWN BY: TomJr

TITLE: MAP VAC BAG STRECHER ASSEMBLY LH

DWG NO: MA261-0009

A

SCALE: N/A

DATE: 1/15/2019

SHEET 1 OF 2

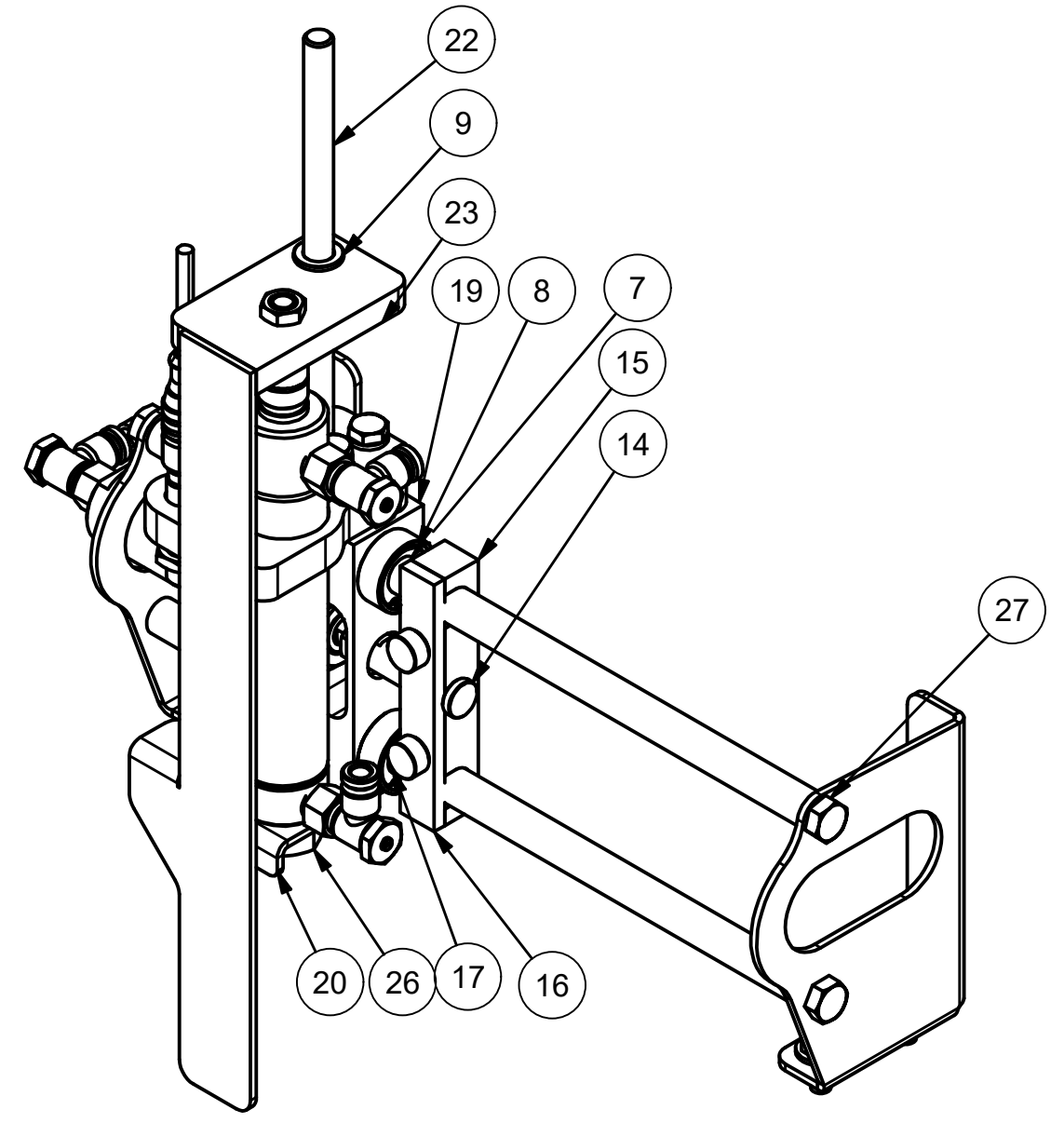
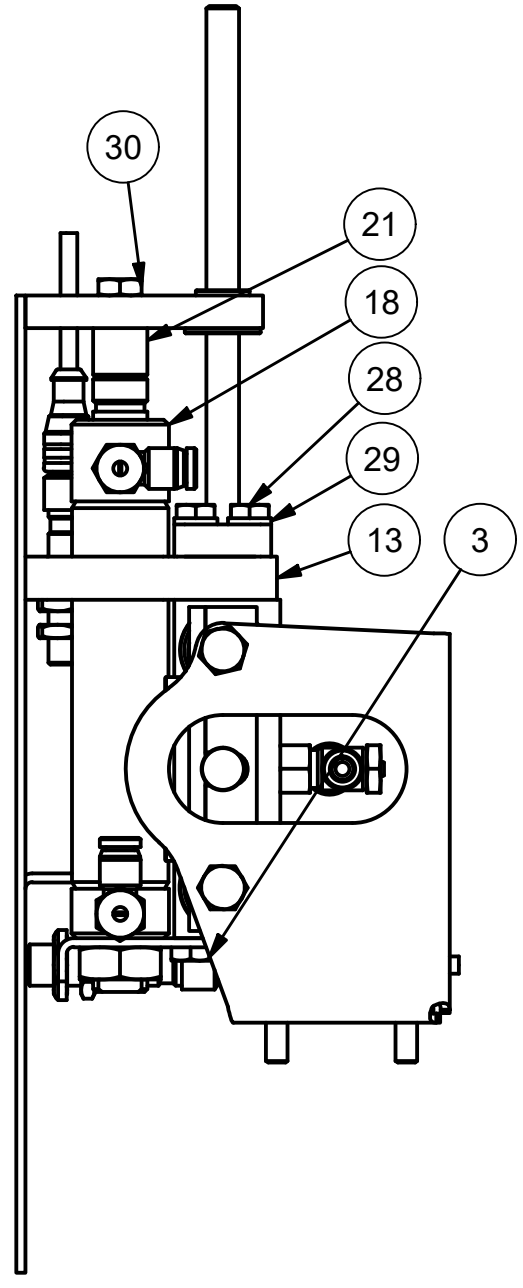
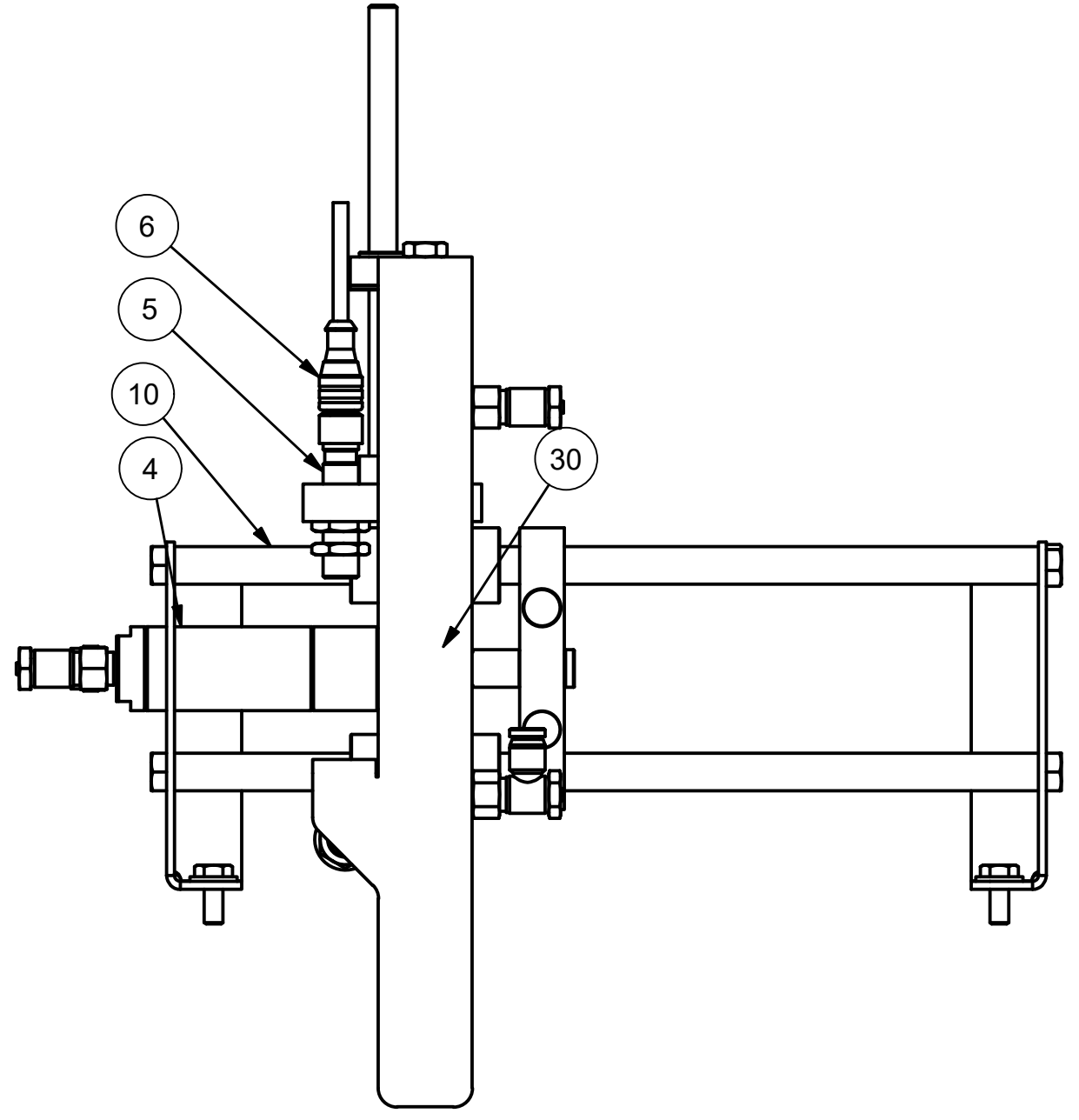
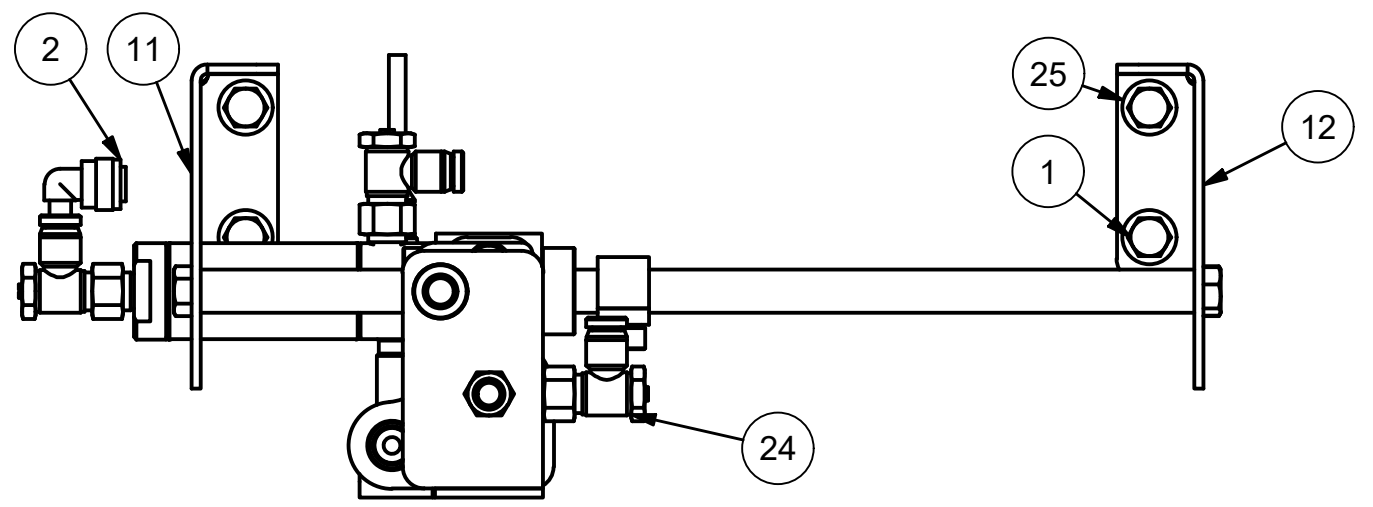

<h1>CV•TEK</h1>	
THIS DRAWING IS THE PROPERTY OF CV•TEK, INC. AND IS TO BE CONSIDERED CONFIDENTIAL. USE OR REPRODUCTION WITHOUT THE EXPRESS PERMISSION OF THE COMPANY IS STRICTLY PROHIBITED.	APPROVED MFG: _____ APPROVED ENG: _____
TOLERANCES: UNLESS OTHERWISE STATED: FRACTIONAL = ± .015 .XX = ± .015 .XXX = ± .005 .XXXX = ± .0005 DRILLED HOLE: STANDARD S.A.F.	DRAWN BY: TomJr
	TITLE: <b>MAP VAC BAG STRECHER ASSEMBLY LH</b>
	DWG NO.: <b>MA261-0009</b>
SCALE: N/A	DATE: 1/15/2019
	SHEET 2 OF 2

PARTS LIST			
ITEM	PART NO.	DESCRIPTION	QTY
1	121302C1	ASHCROFT VACUUM SENSOR	1
2	121501C1	M12 5-5 PIN 90DEGREE 1.5METER BLACK CABLE (FOR ASHCROFT)	1
3	71601101	3/4 SEAL RING	1
4	71607403	ASCO VALVE PLUG CABLE 18mm 3m	1
5	73103701	3/8 NPT BRASS N.C. 24 VAC	1
6	74103301	1 X 3/4 NPT MALE HOSE BARB	1
7	74200601	1/2 TUBE X 1/2 NPT JACO MALE CONN., PLASTIC	2
8	74203101	1/2 OD TUBE X 3/8 NPT MALE CONNECTOR, PLASTIC	1
9	74300701	3/4 NPT FEMALE ELBOW, FORGED BRASS	1
10	74300901	3/4 NPT FEM TEE FORGED	1
11	74301501	3/4 UNION, CAST	1
12	74302401	3/4 NPT MALE X 1/2 NPT FEMALE HEX HEAD BUSHING	1
13	74303001	3/4 LOCKNUT BRASS EXTRUDED	2
14	74303401	3/4 CLOSE NIPPLE	1
15	74303601	1/2M X 3/8M HEX REDUCER NIPPLE	1
16	74304101	3/4 NPT HEX NIPPLE, BRASS	1
17	74304601	3/4 STREET ELBOW, EXTRUDED	1
18	74305701	3/4 X 4 NIPPLE W/2-1/2 EXTENDED THREAD ON ONE END, BRASS	1
19	75001701	HOSE CLAMP #16 WORM GEAR S/S	1
20	79200101A	VACUUM Y WHITE DELRIN	1

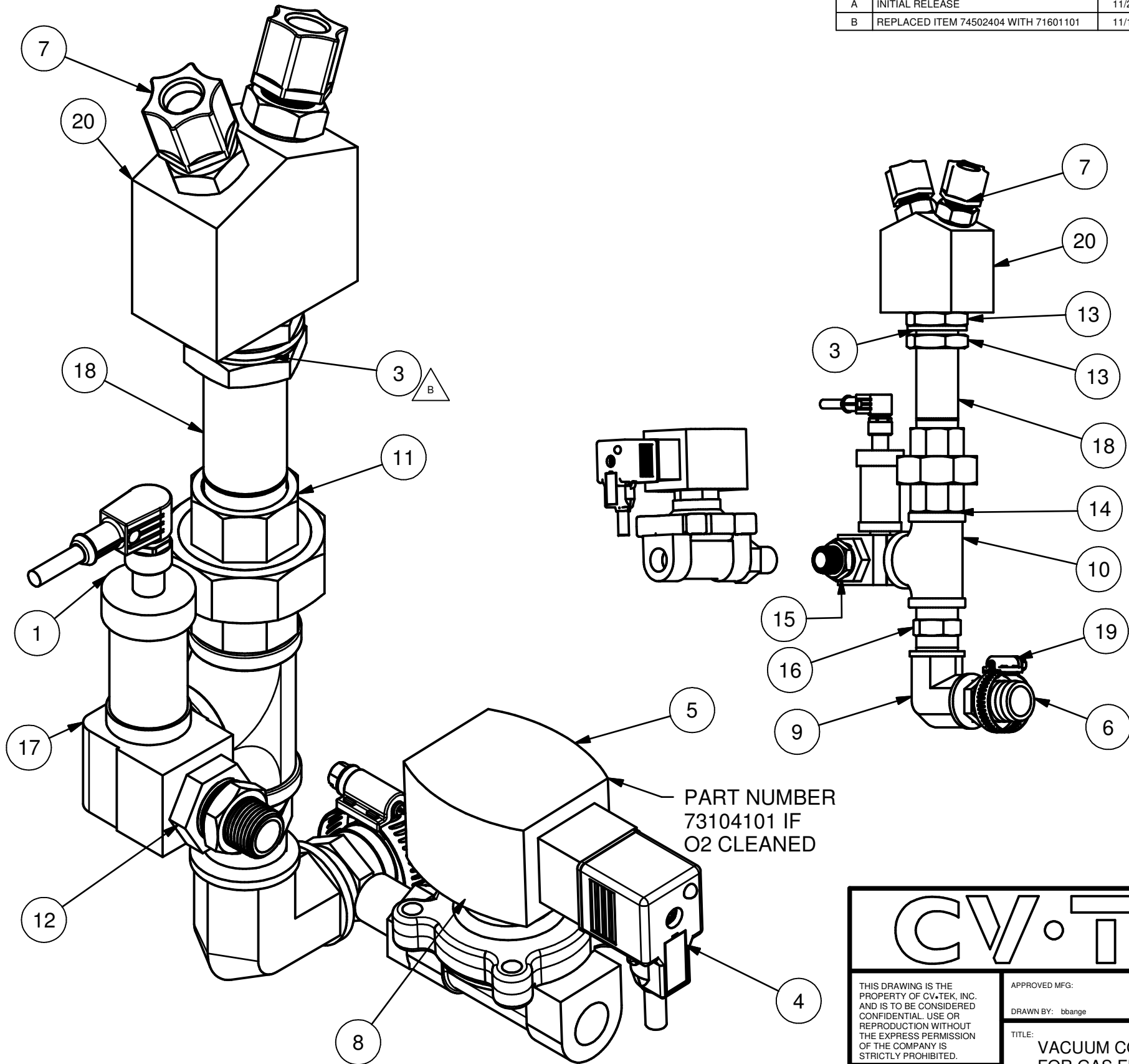

REVISIONS			
REV	DESCRIPTION	DATE	APPROVED
A	INITIAL RELEASE	11/22/2019	MTEKCORP\bbange
B	REPLACED ITEM 74502404 WITH 71601101	11/15/2024	VK

PART NUMBER  
73104101 IF  
O2 CLEANED

# CV•TEK

THIS DRAWING IS THE PROPERTY OF CV•TEK, INC. AND IS TO BE CONSIDERED CONFIDENTIAL. USE OR REPRODUCTION WITHOUT THE EXPRESS PERMISSION OF THE COMPANY IS STRICTLY PROHIBITED.

TOLERANCES: UNLESS OTHERWISE STATED:  
 FRACTIONAL = ± .015  
 XX = ± .015  
 .XXX = ± .005  
 .XXXX = ± .0005  
 DRILLED HOLE: STANDARD S.A.E.

APPROVED MFG:	APPROVED ENG:
DRAWN BY: bbange	
TITLE: VACUUM CONTROL PIPING OPTION FOR GAS FLUSH	
DWG NO.:	MA101-0002
SCALE: N/A	DATE:
	SHEET 1 OF 1

PARTS LIST			
ITEM	PART NO.	DESCRIPTION	QTY
1	129508C1	REGULATOR	1
2	63100301	HOBBS PRESSURE SWITCH ASSEMBLY	1
3	71601101	3/4 SEAL RING	1
4	73502701	NORGREN PRESSURE GAUGE, 0-160 PSI, 1/4 NPT REAR MOUNTING	1
5	74203001	3/8 OD TUBE x 1/4 NPT MALE CONNECTOR, PLASTIC	2
6	74203201	3/8 NPT MALE X 3/8 O.D. TUBE	1
7	74204201	3/8 O.D. TUBE X 1/4 NPT FIXED ELBOW, MALE, PLASTIC	1
8	74300401	1/2 NPT X 1 1/2 BULK HEAD COUPLING	1
9	74300501	1/4 X 1-1/2 bulkhead coupling	1
10	74301201	1/4 UNION	1
11	74301701	1/4 plug, hex countersunk	1
12	74301901	1/2 PLUG HEX HEAD HOLLOW	1
13	74302301	1/2 NPT MALE x 3/8 NPT FEMALE HEX HEAD BUSHING, BRASS	1
14	74302501	1/4 NPT MALE X 1/8 NPT FEMALE HEX HEAD BUSHING	1
15	74303101	1/4 CLOSE NIPPLE	1
16	74303501	3/8 NPT MALE X 1/4 NPT MALE HEX REDUCER NIPPLE, HEX	1
17	74304401	1/4 STREET ELBOW, EXTRUDED	1
18	74305901	1/4 NPT MALE RUN TEE, EXTRUDED BRASS	1
19	74306001	3/8 NPT MALE RUN TEE	1

REVISIONS			
REV	DESCRIPTION	DATE	APPROVED
A	DRAWING CREATED	11/22/2019	MTEKCORP\bbange
B	NOT DOCUMENTED	7/16/2021	MTEKCORP\akalina
C	UPDATED DRAWING TITLE BLOCK	11/15/2024	G.W.
D	EDITED BOM ITEMS 1 & 3 TO MATCH INFOR	12/6/2024	G.W.

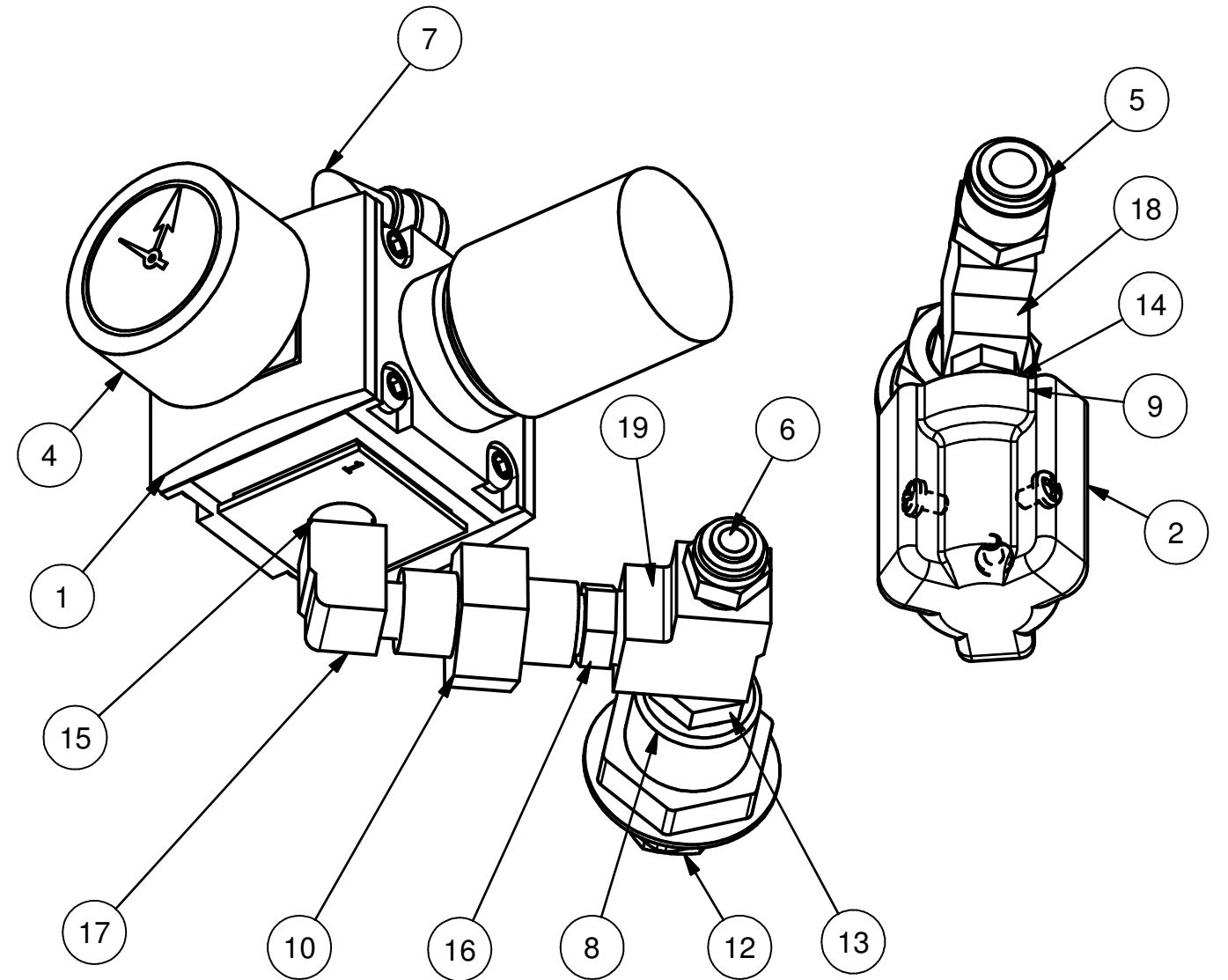

<h1>CV•TEK</h1>	
THIS DRAWING IS THE PROPERTY OF CV•TEK, INC. AND IS TO BE CONSIDERED CONFIDENTIAL. USE OR REPRODUCTION WITHOUT THE EXPRESS PERMISSION OF THE COMPANY IS STRICTLY PROHIBITED.	APPROVED MFG: _____ APPROVED ENG: _____
TOLERANCES: UNLESS OTHERWISE STATED: FRACTIONAL = ± .015 XX = ± .015 .XXX = ± .005 XXXX = ± .0005 DRILLED HOLE: STANDARD S.A.E.	DRAWN BY: C.ILONTA TITLE: <b>GAS PRESSURE REGULATOR AND PIPING</b>
	DWG NO.: <b>MA101-0003</b> <span style="float: right;">D</span>
SCALE: N/A	DATE: _____ SHEET 1 OF 1

REVISION			
REV	DESCR	DATE	APRVD
A	INITIAL RELEASE	7/21/2021	AOK
B	ADDED 71601001,74307801,268P-08-04 &129508C1	11/18/24	RB

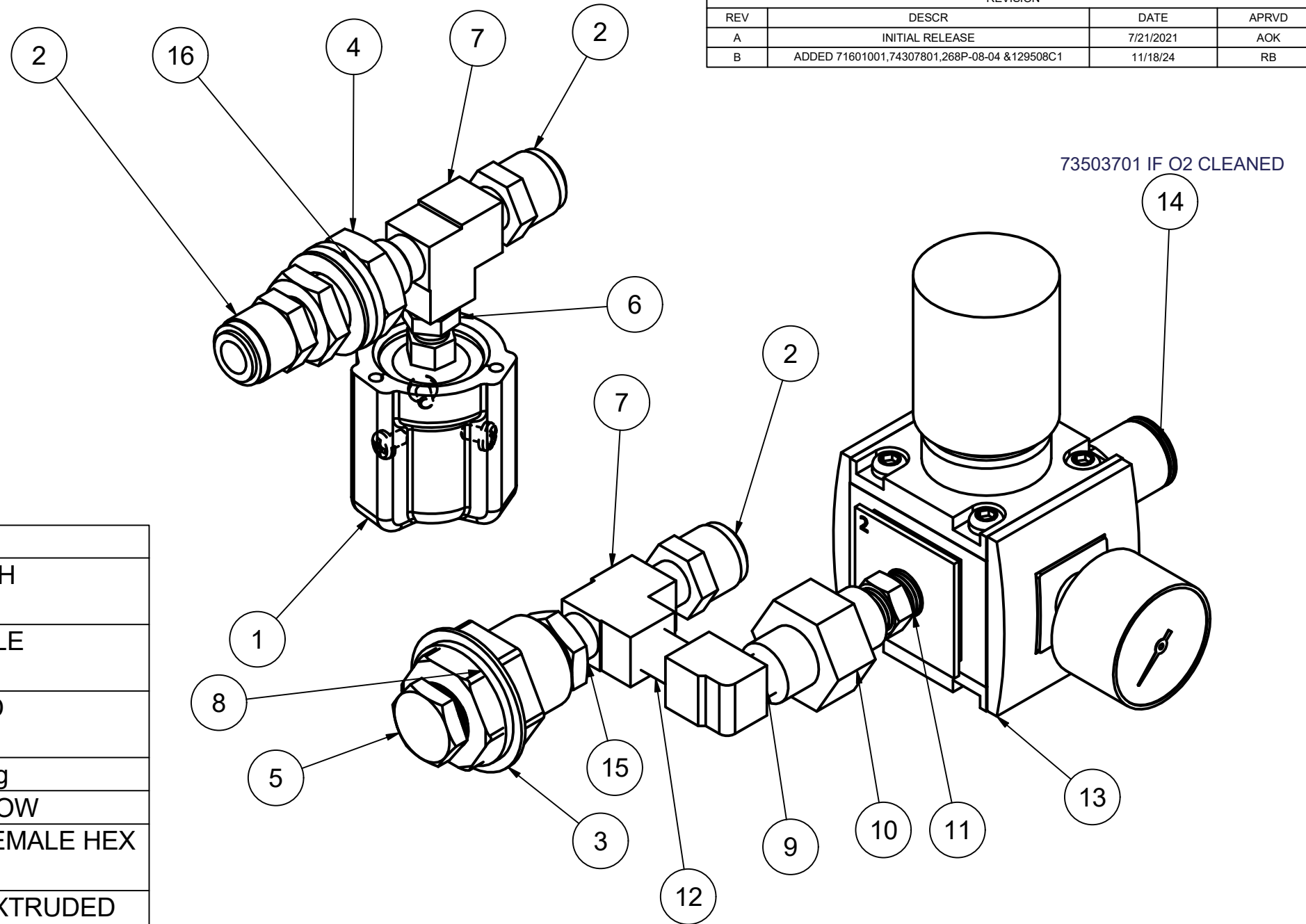

### Parts List

1	1	63100301	HOBBS PRESSURE SWITCH ASSEMBLY
2	3	74203001	3/8 OD TUBE x 1/4 NPT MALE CONNECTOR, PLASTIC
3	1	74300401	1/2 NPT X 1 1/2 BULK HEAD COUPLING
4	1	74300501	1/4 X 1-1/2 bulkhead coupling
5	1	74301901	1/2 PLUG HEX HEAD HOLLOW
6	1	74302501	1/4 NPT MALE X 1/8 NPT FEMALE HEX HEAD BUSHING
7	2	74305901	1/4 NPT MALE RUN TEE, EXTRUDED BRASS
8	1	71601101	3/4 SEAL RING
9	1	74304401	1/4 STREET ELBOW, EXTRUDED
10	1	74301201	1/4 UNION
11	1	74303701	1/4 NPT hex nipple - long
12	1	74303101	1/4 CLOSE NIPPLE
13	1	129508C1	REGULATOR
14	1	268P-08-04	FITTING, TBG, STR. 1/2OD X 1/4NPT
15	1	74307801	1/2 NPT Male X 1/4 NPT Female pipe bushing, brass
16	1	71601001	Seal ring; 1/2 S/S

# CV-TEK

THIS DRAWING IS THE PROPERTY OF CV TEK, INC. AND IS TO BE CONSIDERED CONFIDENTIAL. USE OR REPRODUCTION WITHOUT THE EXPRESS PERMISSION OF THE COMPANY IS STRICTLY PROHIBITED.

TOLERANCES: UNLESS OTHERWISE STATED:  
 NOMINAL = ± .1  
 .XX = ± .1  
 .XXX = ± .01  
 .XXXX = ± .005  
 DRILLED HOLE: STANDARD ISO

APPROVED MFG: \_\_\_\_\_ APPROVED ENG: \_\_\_\_\_

DRAWN BY: C.ILONTA

TITLE: **GAS PRESSURE REGULATOR AND PIPING**

DWG NO: **MA101-0007**

SCALE: N/A

DATE: \_\_\_\_\_

SHEET 1 OF 1

B

PARTS LIST			
ITEM	PART NO.	DESCRIPTION	QTY
1	129514C1	LUBRICATOR	1
2	74103601	3/8 X 3/8 MALE ELBOW BRASS	1
3	129534C1	FILTER REGULATOR, L2R	1
4	129511C1	BODY TO BODY CONNECTOR	3
5	129513C1	DRY AIR	1
6	129505C2	SHUT OFF	1
7	129771C1	LUBRICATOR VINYL CAP	1
8	AS 1968 - 1976 - 5	Helical spring lock washers (metric series)	2
9	129562C1	MK3 FRL MOUNT	1
10	ANSI B18.2.3.5M - M5 x 0.8 x 10	Hex Bolt	2

REVISIONS			
REV	DESCRIPTION	DATE	APPROVED
A	INITIAL CREATION	5/25/2021	A.K.

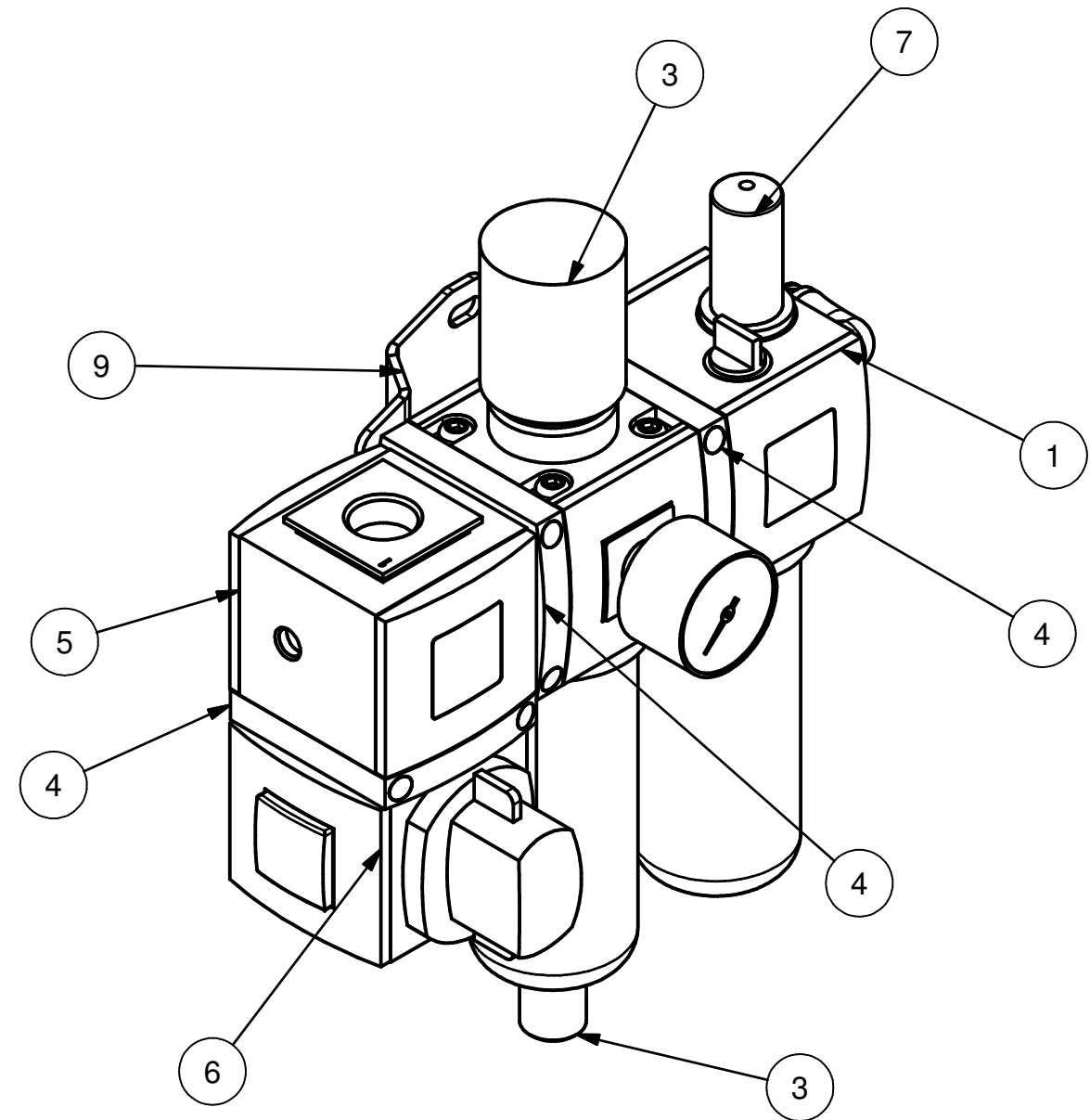
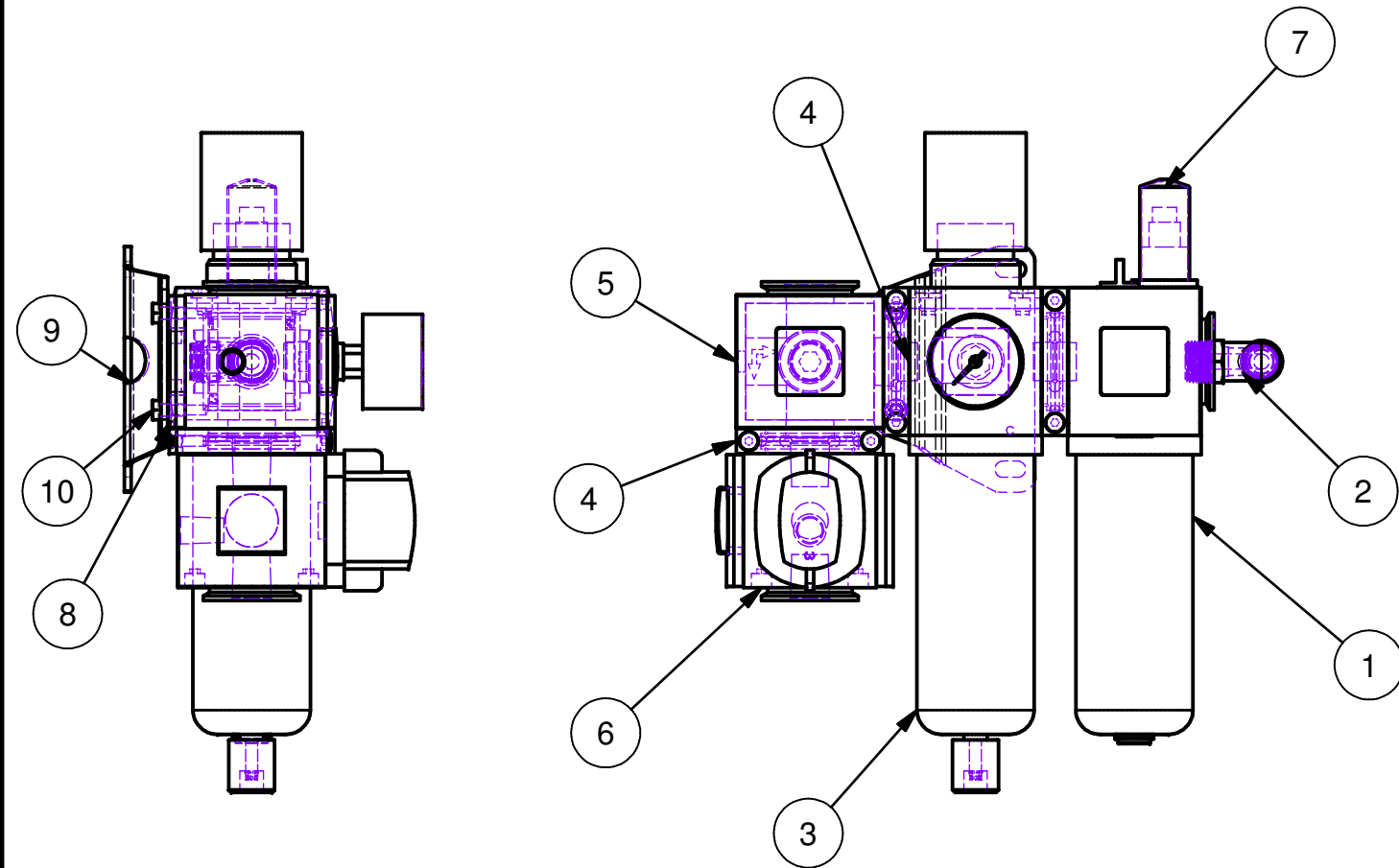

# CV•TEK

THIS DRAWING IS THE PROPERTY OF CV•TEK, INC. AND IS TO BE CONSIDERED CONFIDENTIAL. USE OR REPRODUCTION WITHOUT THE EXPRESS PERMISSION OF THE COMPANY IS STRICTLY PROHIBITED.

TOLERANCES: UNLESS OTHERWISE STATED:  
 FRACTIONAL = ± .015  
 XX = ± .015  
 .XXX = ± .005  
 .XXXX = ± .0005  
 DRILLED HOLE: STANDARD S.A.E.

APPROVED MFG: \_\_\_\_\_ APPROVED ENG: \_\_\_\_\_

DRAWN BY: akalina

TITLE: \_\_\_\_\_

FRL L2R W/ SHUTOFF

DWG NO.: 129809C1

SCALE: N/A DATE: \_\_\_\_\_ SHEET 1 OF 1

A

PARTS LIST			
ITEM	PART NO.	DESCRIPTION	QTY
1	111008C1	2.5KVA 220/380/415/440 X 24/115 VAC 50/60 HZ	1
2	71400901	Fuse 4 amp type aM	1
3	71401101	Fuse 8 amp type aM	2
4	75102601	1/4 MED SPLIT LOCK WASHERS, S/S	4
5	75103301	1/4 FLAT WASHER, 0.625 O.D., 0.06 THCK, S/S	4
6	75103801	1/4-20 HEX NUT, S/S	4
7	75110901	1/4-20 X 3/4 SEALING HEX HEAD CAP SCREW, S/S	4
8	71400701	Fuse 1 amp type aM	3
9	71401001	Fuse 6 amp type aM	2

CHANGE FUSES #2 & #3 AS REQUIRED

REVISIONS			
REV	DESCRIPTION	DATE	APPROVED
A	INITIAL RELEASE	11/02/2018	CI
B	ADD 71400701 AND 71401001	11/15/2024	VK

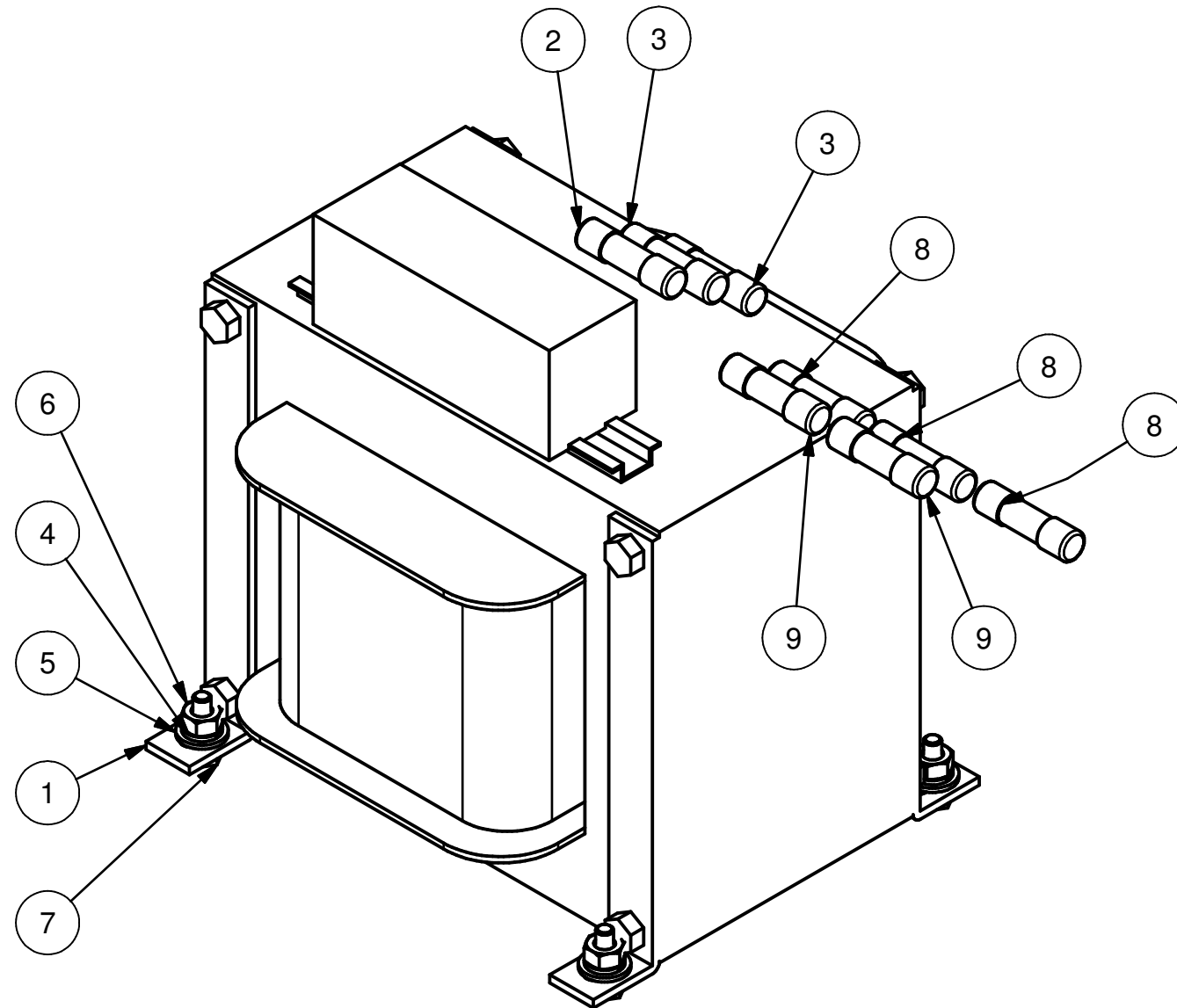

<h1>CV•TEK</h1>	
THIS DRAWING IS THE PROPERTY OF CV•TEK, INC. AND IS TO BE CONSIDERED CONFIDENTIAL. USE OR REPRODUCTION WITHOUT THE EXPRESS PERMISSION OF THE COMPANY IS STRICTLY PROHIBITED.	APPROVED MFG: _____ APPROVED ENG: _____
TOLERANCES: UNLESS OTHERWISE STATED: FRACTIONAL = ± .015 XX = ± .015 .XXX = ± .005 XXXX = ± .0005 DRILLED HOLE: STANDARD S.A.E.	DRAWN BY: C.I.LONTA
	TITLE: <b>MK3 ALTRAN POWER ASSEMBLY</b>
	DWG NO.: <b>MA110-0035</b> <span style="float: right;">B</span>
SCALE: N/A	DATE: _____ SHEET 1 OF 1

PARTS LIST			
ITEM	PART NO.	DESCRIPTION	QTY
1	125764C1	CV HYBRID FUSE PANEL	1
2	71002701	RAIL, DIN 34 mm WIDE (METERS)	1
3	120752C1	END CLAMP, WIDTH: 9.5 MM, COLOR: GRAY	2
4	120475C2	FUSE BLOCK, MIDGET FUSE, 600V 32AMP	10
5	120746C1	1 TIER FEED THROUGH TERMINAL BLOCK; AWG: 26-12; W; 5.2MM; GRAY	10
6	120751C1	1 TIER PE FEED THROUGH TERMINAL BLOCK; AWG:26-12; W:5.2MM; GRN/YEL	1
7	120747C1	END COVER, L: 65.4 MM, W: 2.2 MM, H: 47.5 MM, COLOR: GRAY	1
8	71300801	WIRE DUCT 1 W X 1.5 H, WHITE T&B	2
9	71300901	WIRE DUCT COVER 1" WIDE, WHITE T&B	2

REVISIONS			
REV	DESCRIPTION	DATE	APPROVED
A	INITIAL RELEASE	03/04/2019	N.B

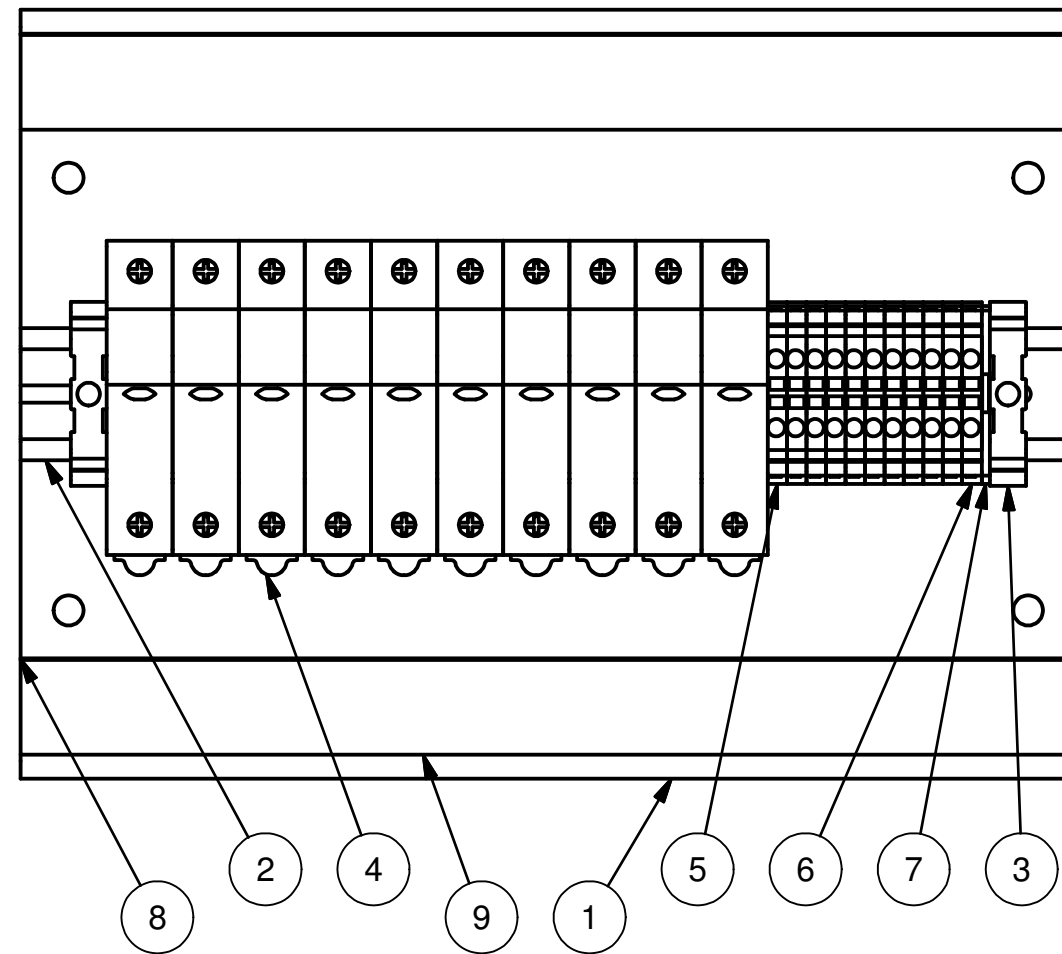

<h1>CV•TEK</h1>	
THIS DRAWING IS THE PROPERTY OF CV•TEK, INC. AND IS TO BE CONSIDERED CONFIDENTIAL. USE OR REPRODUCTION WITHOUT THE EXPRESS PERMISSION OF THE COMPANY IS STRICTLY PROHIBITED.  TOLERANCES: UNLESS OTHERWISE STATED: FRACTIONAL = ± .015 XX = ± .015 .XXX = ± .005 .XXXX = ± .0005 DRILLED HOLE: STANDARD S.A.E.	APPROVED MFG: _____ APPROVED ENG: _____  DRAWN BY: TomJr  TITLE: <b>CV HYBRID FUSE PANEL ASSEMBLY</b>
	DWG NO.: <b>MA110-0036</b> <span style="float: right;">A</span>
	SCALE: N/A      DATE: _____      SHEET 1 OF 1

PARTS LIST			
ITEM	PART NO.	DESCRIPTION	QTY
1	120716C1	TWO TIER TERMINAL BLOCK	8
2	120717C1	PARTITION PLATE FOR TWO TIER TERMINAL BLOCK	3
3	120746C1	1 TIER FEED THROUGH TERMINAL BLOCK; AWG: 26-12; W; 5.2MM; GRAY	10
4	120747C1	END COVER, L: 65.4 MM, W: 2.2 MM, H: 47.5 MM, COLOR: GRAY	8
5	120749C1	1 TIER FEED THROUGH TERMINAL BLOCK; AWG: 24-8; W; 8.2MM; GRAY	2
6	120751C1	1 TIER PE FEED THROUGH TERMINAL BLOCK; AWG:26-12; W:5.2MM; GRN/YEL	1
7	120752C1	END CLAMP, WIDTH: 9.5 MM, COLOR: GRAY	6
8	121105C1	GROUND TB, 2 POINT, GRN/YEL, 10MM^2	2
9	121494C1	SPACER PLATE FOR TWO TIER TERMINAL BLOCK	1
10	125089C1	2 AMP DIN MOUNT POWER SUPPLY	1
11	125730C1	B&R CONTROLLER	1
12	125765C1	CV HYBRID ELECTRICAL PANEL	1
13	126047C1	BANNER SC10-2ROE SAFETY RELAY	1
14	71002701	RAIL, DIN 34 mm WIDE (METERS)	3
15	71023201	PHOENIX CONTACT PLC-RSC-24DC/1/ACT	13
16	71104502	Relay, solid state 24-265VAC	1
17	71300801	WIRE DUCT 1 W X 1.5 H, WHITE T&B	5
18	71300901	WIRE DUCT COVER 1" WIDE, WHITE T&B	5
19	71404701	MINI CONTACTOR 24VAC	1
20	71404901	LOVATO OVERLOAD 0.9-1.5 AMP	1
21	75112101	#10-32 X 3/8 PAN HEAD, SLOTTED, S/S	2

REVISIONS			
REV	DESCRIPTION	DATE	APPROVED
A	INITIAL RELEASE	03/04/2019	N.B
B	UPDATES PER DAVE	03/03/2020	N.B.
C	MADE ADJUSTMENTS TO ADD XP20 SYSTEM TO CONTROLLER	06/09/2020	N.B.
D	71003301, 71106501 AND 71106401 HAVE BEEN REMOVED	11/06/2024	S.P.

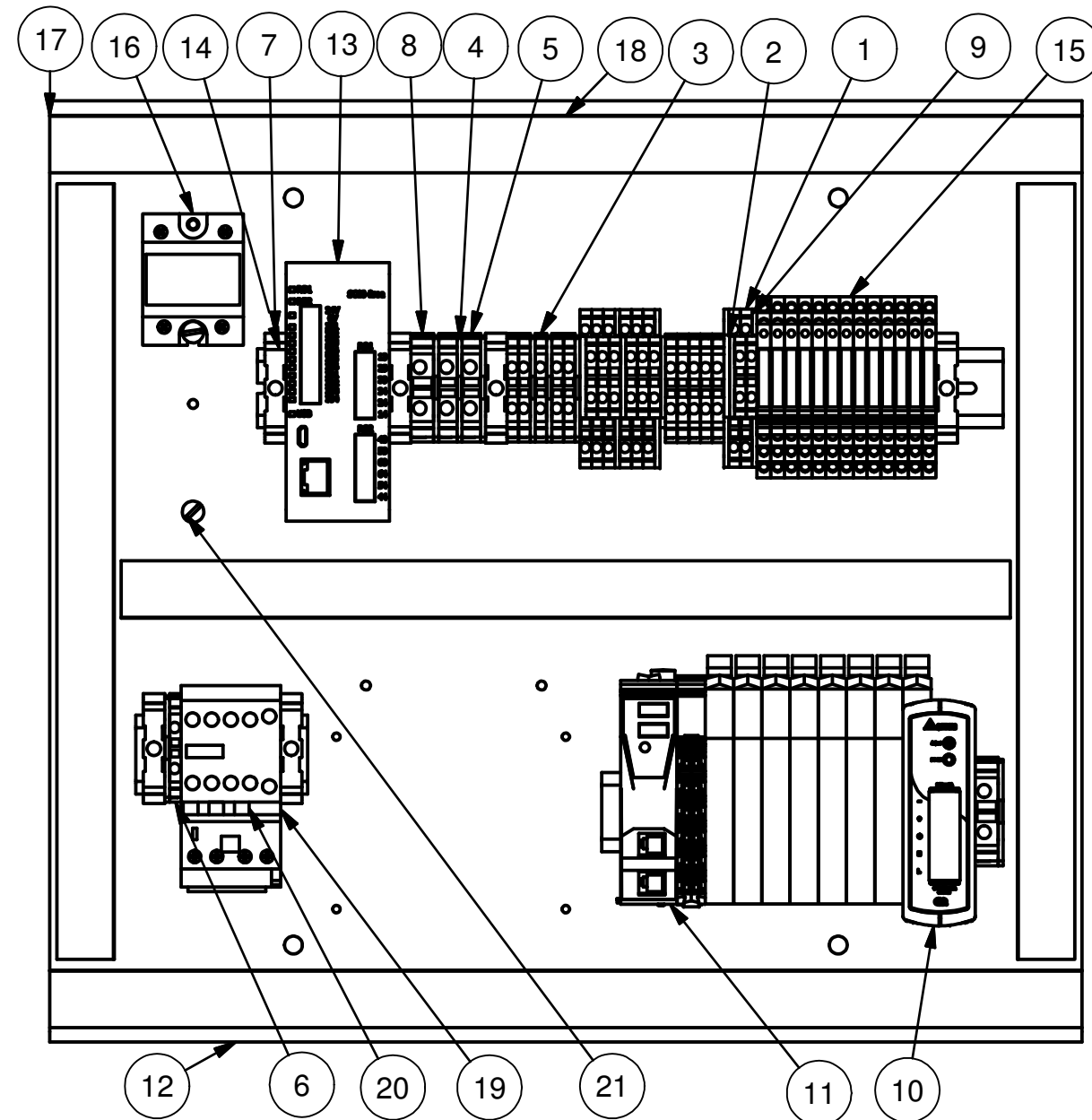

CV•TEK

THIS DRAWING IS THE PROPERTY OF CV•TEK, INC. AND IS TO BE CONSIDERED CONFIDENTIAL. USE OR REPRODUCTION WITHOUT THE EXPRESS PERMISSION OF THE COMPANY IS STRICTLY PROHIBITED.	APPROVED MFG: _____ APPROVED ENG: _____ DRAWN BY: TomJr TITLE:
TOLERANCES: UNLESS OTHERWISE STATED: FRACTIONAL = ± .015 XX = ± .015 .XXX = ± .005 .XXXX = ± .0005 DRILLED HOLE: STANDARD S.A.E.	MAP-VAC PANEL LAYOUT DWG NO.: <b>MA110-0037</b>
SCALE: N/A	DATE: _____ SHEET 1 OF 1

REVISIONS			
REV	DESCRIPTION	DATE	APPROVED
A	INITIAL RELEASE		N.B

PARTS LIST			
ITEM	PART NO.	DESCRIPTION	QTY
1	122719C1	X20 TERMINAL BLOCK 12PT	8
2	126077C1	X20 POWER SUPPLY MODLE	1
3	122720C1	X20 BUS MODULE	8
4	126078C1	X20 DIGITAL INPUT MODULE SINK	2
5	126081C1	X20 ANALOG OUTPUT MODULE 2	1
6	126082C1	BUS CONTROLLER	1
7	124960C1	X20 DIGITAL OUTPUT SLICE	2
8	126079C1	X20 ANALOG TEMP INPUT MODULE	1
9	126080C1	X20 ANALOG INPUT MODULE 2	1
10	126151C1	X20 COMPACT POWER SUPPLY MODULE	1

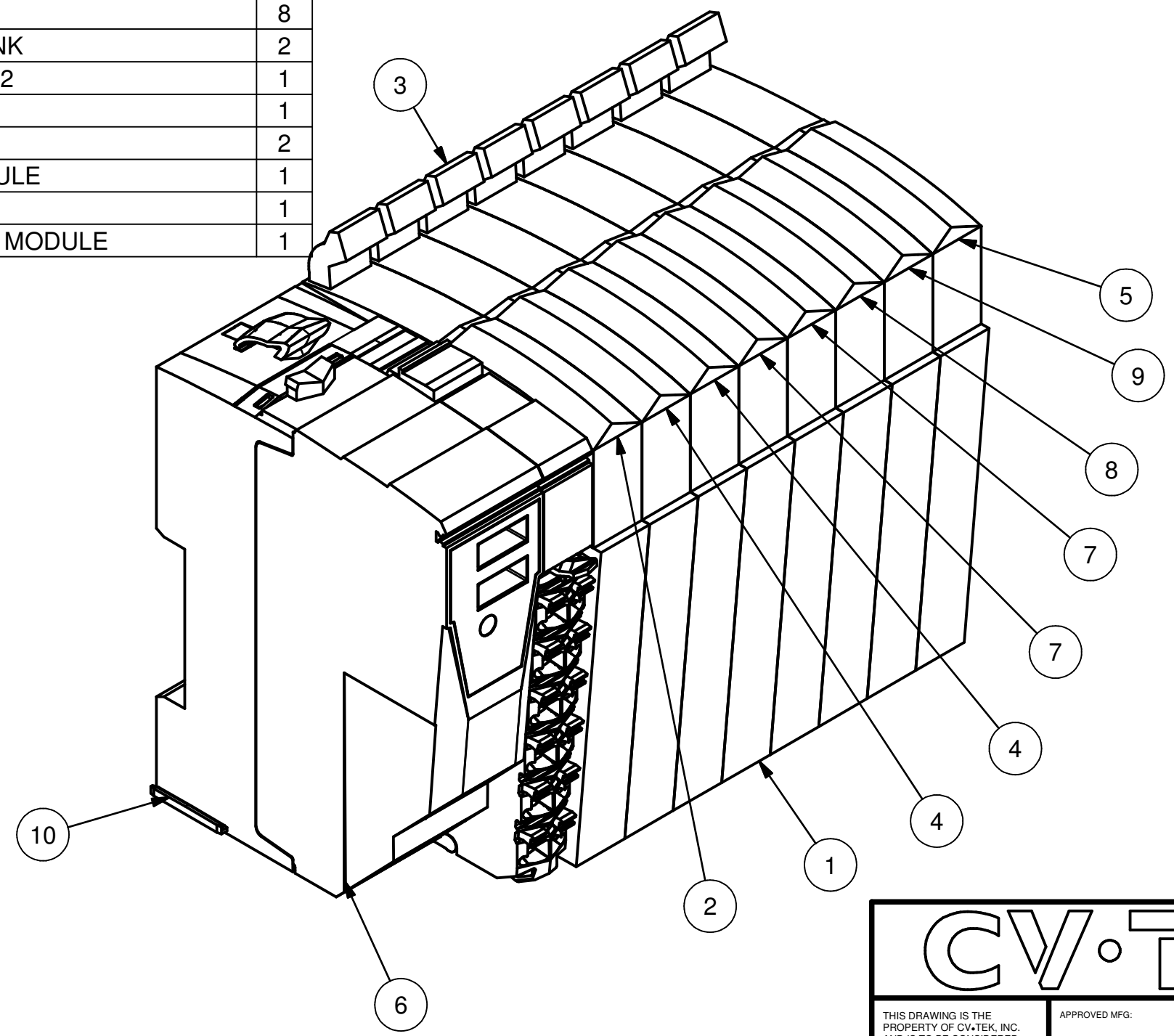

# CV•TEK

THIS DRAWING IS THE PROPERTY OF CV•TEK, INC. AND IS TO BE CONSIDERED CONFIDENTIAL. USE OR REPRODUCTION WITHOUT THE EXPRESS PERMISSION OF THE COMPANY IS STRICTLY PROHIBITED.

TOLERANCES: UNLESS OTHERWISE STATED:  
 FRACTIONAL = ± .015  
 XX = ± .015  
 .XXX = ± .005  
 .XXXX = ± .0005  
 DRILLED HOLE: STANDARD S.A.E.

APPROVED MFG:	APPROVED ENG:
DRAWN BY: TomJR	
TITLE:	
B&R CONTROLLER	
DWG NO.: 125730C1	A
SCALE: N/A	DATE:
SHEET 1 OF 1	

REVISIONS			
REV	DESCRIPTION	DATE	APPROVED
A	INITIAL RELEASE		N.B

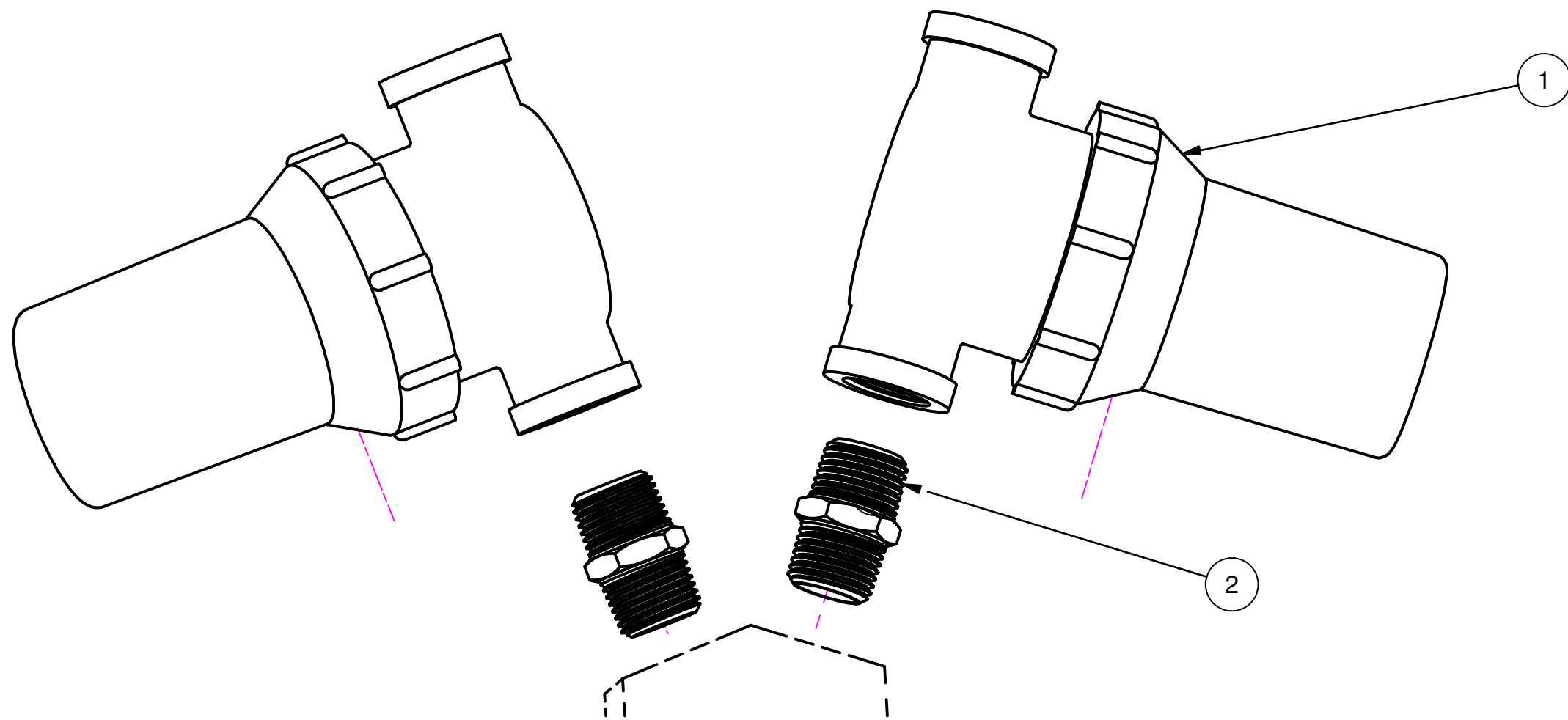

\*REPLACEMENT MESH FILTER 72202601\*

PARTS LIST

ITEM	PART NO.	DESCRIPTION	QTY
1	72202401	PARTICLE, PER PROBE FILTER	2
2	74304001	1/2 HEX NIPPLE	2

# CV•TEK

THIS DRAWING IS THE PROPERTY OF CV•TEK, INC. AND IS TO BE CONSIDERED CONFIDENTIAL. USE OR REPRODUCTION WITHOUT THE EXPRESS PERMISSION OF THE COMPANY IS STRICTLY PROHIBITED.

TOLERANCES: UNLESS OTHERWISE STATED:  
 FRACTIONAL = ± .015  
 XX = ± .015  
 .XXX = ± .005  
 .XXXX = ± .0005  
 DRILLED HOLE: STANDARD S.A.E.

APPROVED MFG:	APPROVED ENG:
DRAWN BY: RB	
TITLE:	
PARTICLE (PER PROBE ASSEMBLY)	
DWG NO.: MA185-0009	A
SCALE: N/A	DATE:
SHEET 1 OF 1	

PARTS LIST			
ITEM	PART NO.	DESCRIPTION	QTY
1	72200101	CANISTER FILTER TANK, S/S 9" ID	1
2	72200201	FILTER, PAPER FOR CANISTER TANK	1
3	72200501A	LID, CANISTER TANK 1/2 NPT	1
4	72200601	GASKET, CANISTER LID	1
5	72200701	MOUNT TUBE, 1/2 PIPE CANISTER FILTER	1
6	74103101	3/4 X 1/2 male hose barb	2
8	134376C1	Canister filter hanger	1
9	79501601	CANISTER TANK BUMPER WITH 5/16-18 THREADS	1
10	72200901	KNOB, CANISTER FILTER 1/2 NPT MOUNTING TUBE	1

REVISIONS			
REV	DESCRIPTION	DATE	APPROVED
A	INITIAL RELEASE	11/2/2022	PV

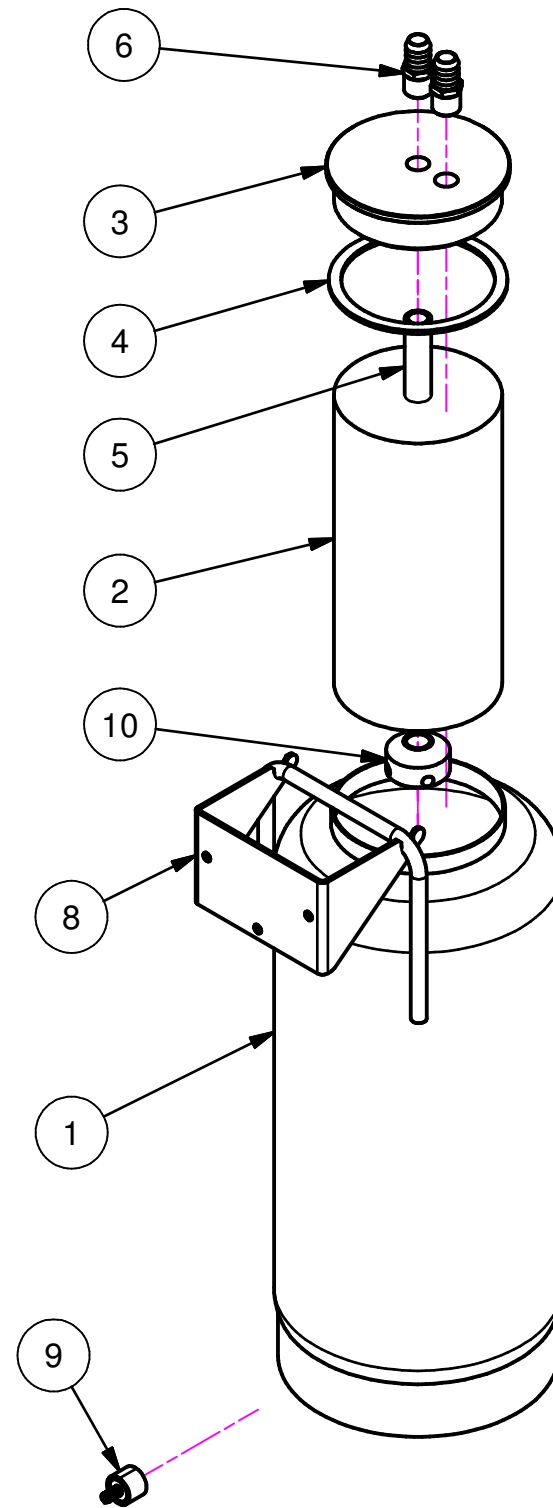
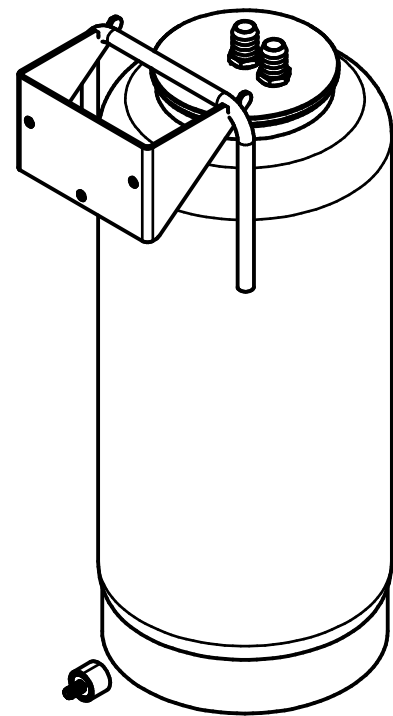

<h1>CV•TEK</h1>	
THIS DRAWING IS THE PROPERTY OF CV•TEK, INC. AND IS TO BE CONSIDERED CONFIDENTIAL. USE OR REPRODUCTION WITHOUT THE EXPRESS PERMISSION OF THE COMPANY IS STRICTLY PROHIBITED.  TOLERANCES: UNLESS OTHERWISE STATED: FRACTIONAL = ± .015 XX = ± .015 .XXX = ± .005 .XXXX = ± .0005 DRILLED HOLE: STANDARD S.A.E.	APPROVED MFG: _____ APPROVED ENG: _____  DRAWN BY: PV  TITLE: <h2 style="text-align: center;">CANISTER, WITH ELEMENT</h2>
	DWG NO.: <b>MA185-0010</b> <span style="float: right;">A</span>
	SCALE: N/A      DATE: 11/2/2022      SHEET 1 OF 1

PARTS LIST			
ITEM	PART NO.	DESCRIPTION	QTY
1	72200101	CANISTER FILTER TANK, S/S 9" ID	1
2	72200501A	LID, CANISTER TANK 1/2 NPT	1
3	72200601	GASKET, CANISTER LID	1
4	72200801	DRAIN TUBE, 1/2 PIPE CANISTER FILTER	1
5	74103101	3/4 X 1/2 male hose barb	4
6	74307201	1/2 STREET ELBOW, 45 DEG.	1
7	76203901A	Canister filter hanger	1
8	79501601	CANISTER TANK BUMPER WITH 5/16-18 THREADS	1
9	74303001	3/4 LOCKNUT BRASS EXTRUDED	4
10	74305701	3/4 X 4 NIPPLE W/2-1/2 EXTENDED THREAD ON ONE END, BRASS	2
11	74300801	3/4 NPT FEMALE ELBOW, CAST BRASS	2
12	75001701	HOSE CLAMP #16 WORM GEAR S/S	4
13	71601101	3/4 SEAL RING	2
14	73301401	POLYWIRE TUBING 3/4 X 3FT	2
15	74103201	3/4 X 3/4 MALE HOSE BARB	2

REVISIONS			
REV	DESCRIPTION	DATE	APPROVED
A	INITIAL RELEASE	8/3/2018	MTEKCOR P\cilonta
B	ADD 2-3X4X3FT POLYWIRE TUBING AND 6 MALE HOSE BAR (QTY 6)	11/19/2024	VK

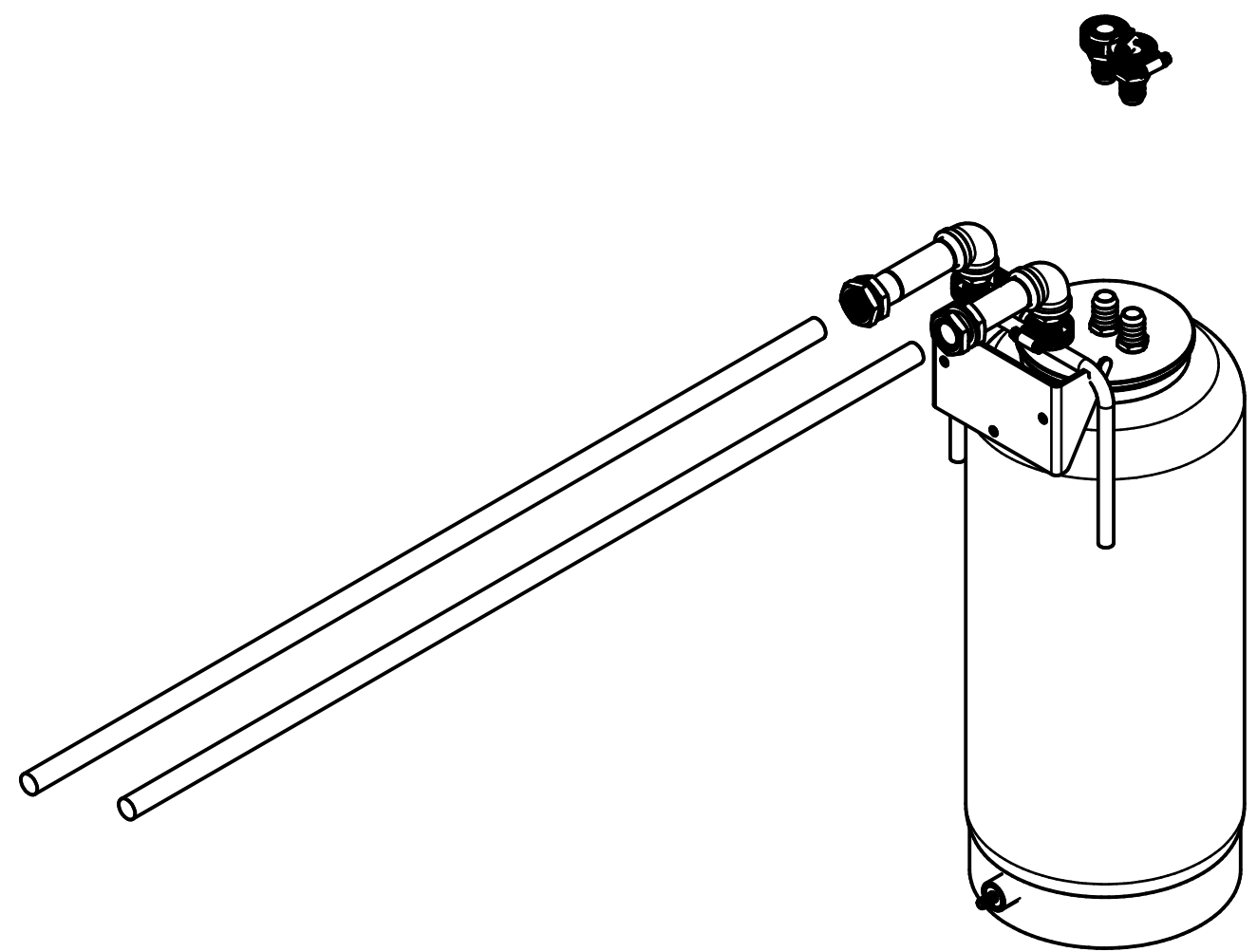
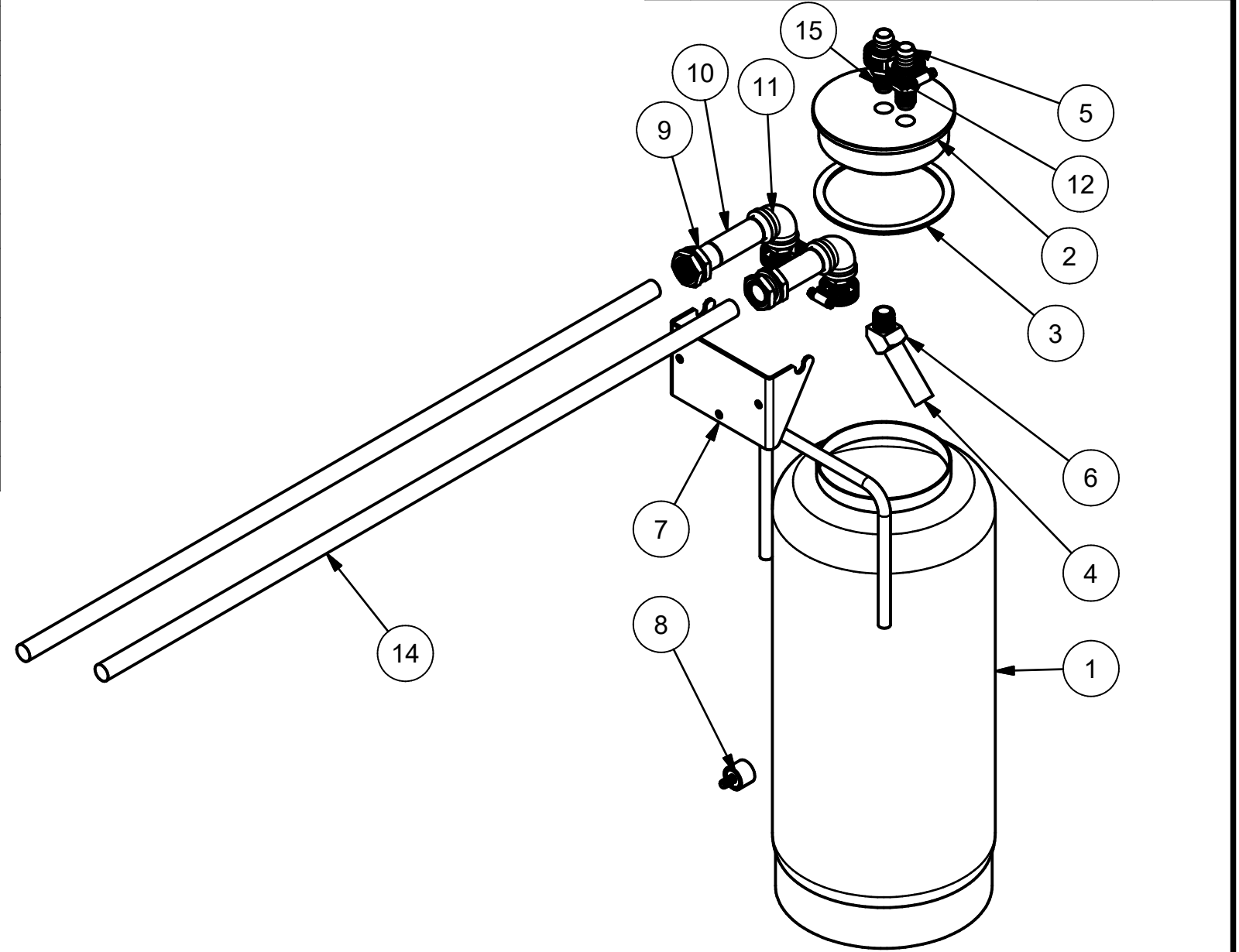

<b>M-TEK</b> INC.	
THIS DRAWING IS THE PROPERTY OF M-TEK, INC. AND IS TO BE CONSIDERED CONFIDENTIAL. USE OR REPRODUCTION WITHOUT THE EXPRESS PERMISSION OF THE COMPANY IS STRICTLY PROHIBITED.	APPROVED MFG: _____ APPROVED ENG: _____
TOLERANCES: UNLESS OTHERWISE STATED: FRACTIONAL = ± .015 XX = ± .015 XXX = ± .005 XXXX = ± .0005 DRILLED HOLE: STANDARD S.A.E.	DRAWN BY: TomJr
	TITLE: CANISTER, WITHOUT ELEMENT
	DWG NO.: MA185-0003
SCALE: N/A	DATE: _____ SHEET 1 OF 1

PARTS LIST			
ITEM	PART NO.	DESCRIPTION	QTY
1	125097C1	3/4 BALL VALVE HANDLE	1
2	72201201	HEAD, CUNO FILTER, BLUE ACETAL	1
3	73102101	ASCO VALVE, 3/4 NPT BRASS N.O. 24 VAC	1
4	73104501	BALL VALVE, 3/4 NPT BRASS 400PSI	1
5	74103301	1 X 3/4 NPT MALE HOSE BARB	2
6	74300801	3/4 NPT FEMALE ELBOW, CAST BRASS	5
7	74301501	3/4 UNION, CAST	1
8	74303001	3/4 LOCKNUT BRASS EXTRUDED	2
9	74303401	3/4 CLOSE NIPPLE	6
10	74305701	3/4 X 4 NIPPLE W/2-1/2 EXTENDED THREAD ON ONE END, BRASS	2
11	75001701	HOSE CLAMP #16 WORM GEAR S/S	2
12	71607403	ASCO VALVE PLUG CABLE 18mm 3m	1
13	62200201	CUNO SUMP ONLY, 1M2 FILTER UNIT, 23.2/590MM, TRANSPARENT	1
14	71601101	3/4 SEAL RING	2
15	72202101	Wrench; for Cuno Sump	1

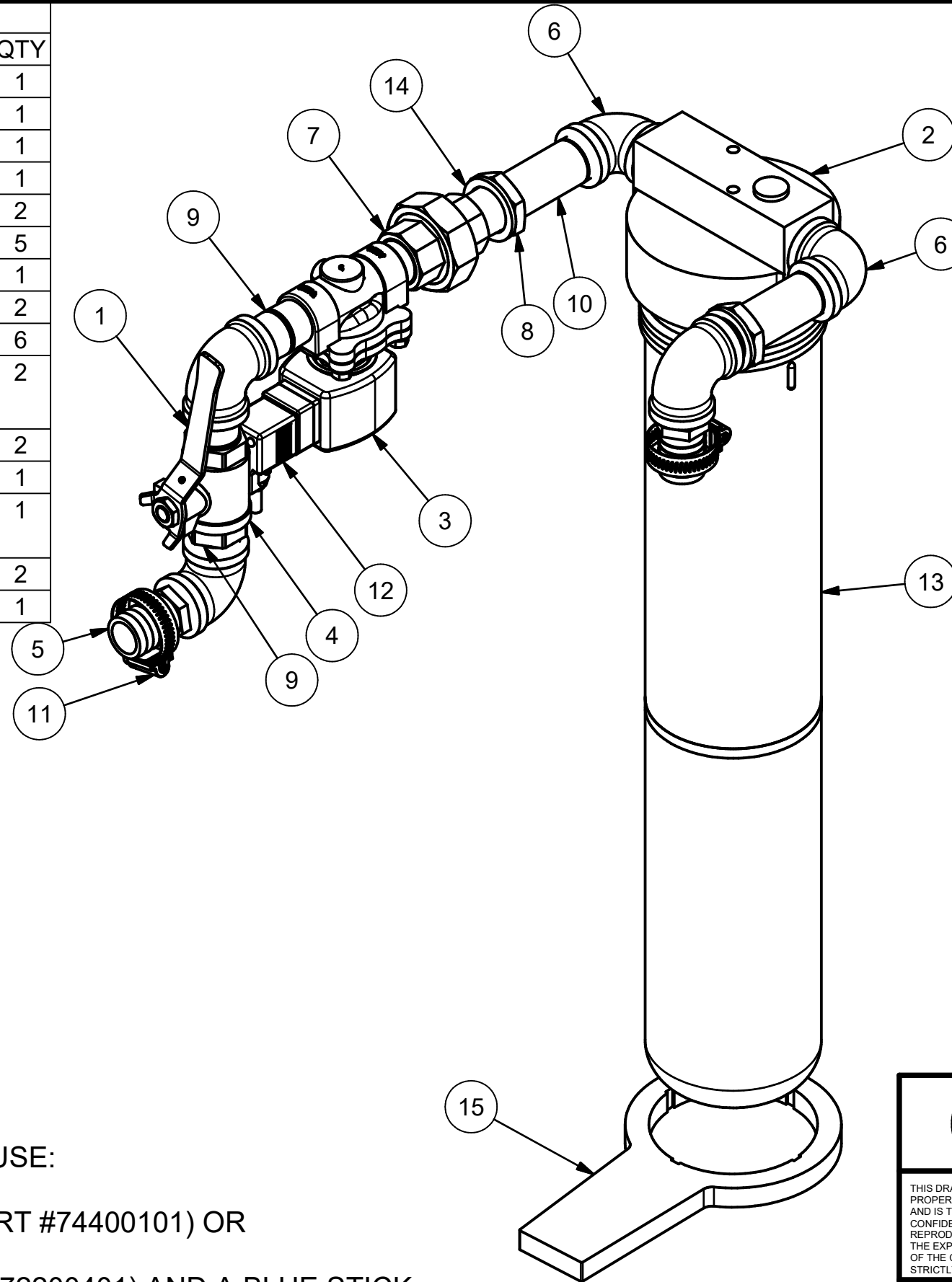

REVISIONS			
REV	DESCRIPTION	DATE	APPROVED
A	INITIAL RELEASE	11/22/2019	MTEKCOR P\bbange
B	ADD PART 71601101 AND 62200201	11/14/2024	VK



**NOTE:** FOR EACH ASSEMBLY, ADDITIONALLY USE:

**OPTION 1:** 1 INCH 45 DEG COPPER ELBOW (PART #74400101) OR

**OPTION 2:** TWO KUNO PAPER FILTERS (PART #72200401) AND A BLUE STICK

<h1>CV•TEK</h1>	
THIS DRAWING IS THE PROPERTY OF CV•TEK, INC. AND IS TO BE CONSIDERED CONFIDENTIAL. USE OR REPRODUCTION WITHOUT THE EXPRESS PERMISSION OF THE COMPANY IS STRICTLY PROHIBITED.	APPROVED MFG: _____ APPROVED ENG: _____
TOLERANCES: UNLESS OTHERWISE STATED: FRACTIONAL = ± .015 XX = ± .015 XXX = ± .005 XXXX = ± .0005 DRILLED HOLE: STANDARD S.A.E.	DRAWN BY: bbange
	TITLE: MK III LONG CUNO ASSEMBLY
	DWG NO.: MA185-0004
SCALE: N/A	DATE: _____ SHEET 1 OF 1

PARTS LIST			
ITEM	PART NO.	DESCRIPTION	QTY
1	72201201	HEAD, CUNO FILTER, BLUE ACETAL	1
2	74303401	3/4 CLOSE NIPPLE	6
3	74300801	3/4 NPT FEMALE ELBOW, CAST BRASS	5
4	74305701	3/4 X 4 NIPPLE W/2-1/2 EXTENDED THREAD ON ONE END, BRASS	2
5	74303001	3/4 LOCKNUT BRASS EXTRUDED	2
6	73104501	BALL VALVE, 3/4 NPT BRASS 400PSI	1
7	125097C1	3/4 BALL VALVE HANDLE	1
8	74103301	1 X 3/4 NPT MALE HOSE BARB	2
9	75001701	HOSE CLAMP #16 WORM GEAR S/S	2
10	74301501	3/4 UNION, CAST	1
11	73102101	ASCO VALVE, 3/4 NPT BRASS N.O. 24 VAC	1
12	71607403	ASCO VALVE PLUG CABLE 18mm 3m	1
13	71601101	3/4 SEAL RING	2
14	72202101	Wrench; for Cuno Sump	1
15	62200301	CUNO SUMP ONLY, 1M2 FILTER UNIT, 13.5/343MM, TRANSPARENT	1

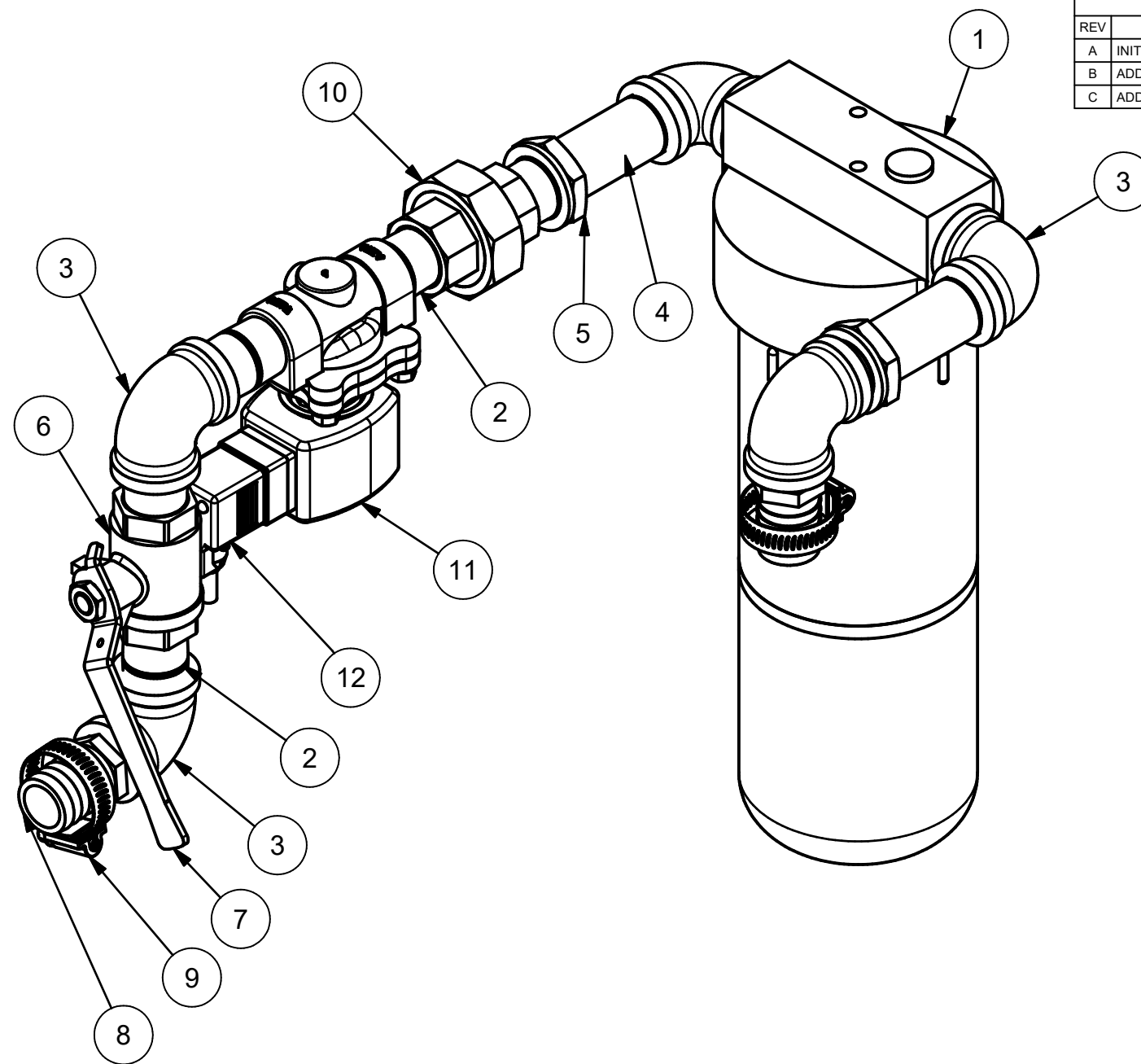

REVISIONS			
REV	DESCRIPTION	DATE	APPROVED
A	INITIAL RELEASE		N.B
B	ADDED NOTE	4/12/2024	PV
C	ADD PARTS 71601101 AND 62200201	11/11/2024	VK



**NOTE:** FOR EACH ASSEMBLY, ADDITIONALLY USE:

**OPTION 1:** 1 INCH 45 DEG COPPER ELBOW (PART #74400101) OR

**OPTION 2:** KUNO PAPER FILTER (PART #72200401)

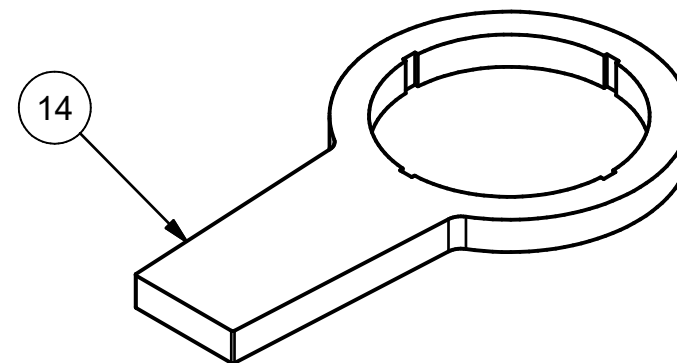

<h1>CV•TEK</h1>	
THIS DRAWING IS THE PROPERTY OF CV•TEK, INC. AND IS TO BE CONSIDERED CONFIDENTIAL. USE OR REPRODUCTION WITHOUT THE EXPRESS PERMISSION OF THE COMPANY IS STRICTLY PROHIBITED.	APPROVED MFG: _____ APPROVED ENG: _____
TOLERANCES: UNLESS OTHERWISE STATED: FRACTIONAL = ± .015 XX = ± .015 XXX = ± .005 XXXX = ± .0005 DRILLED HOLE: STANDARD S.A.E.	DRAWN BY: bbang
	TITLE: MK III SHORT CUNO ASSEMBLY
	DWG NO.: MA185-0005
SCALE: N/A	DATE: _____ SHEET 1 OF 1

PARTS LIST			
ITEM	PART NO.	DESCRIPTION	QTY
1	125097C1	3/4 BALL VALVE HANDLE	1
2	72201201	HEAD, CUNO FILTER, BLUE ACETAL	1
3	72201901	USE 62200201 - CUNO SUMP ONLY, 1M2 FILTER UNIT, 23.2/590MM, TRANSPARENT	1
4	73102101	ASCO VALVE, 3/4 NPT BRASS N.O. 24 VAC	1
5	73104501	BALL VALVE, 3/4 NPT BRASS 400PSI	1
6	74103301	1 X 3/4 NPT MALE HOSE BARB	2
7	74300801	3/4 NPT FEMALE ELBOW, CAST BRASS	5
8	74301501	3/4 UNION, CAST	1
9	74303001	3/4 LOCKNUT BRASS EXTRUDED	2
10	74303401	3/4 CLOSE NIPPLE	6
11	74305701	3/4 X 4 NIPPLE W/2-1/2 EXTENDED THREAD ON ONE END, BRASS	2
12	74502404	PRESSURE-SEALING WASHER 3/4" S/S	2
13	75001701	HOSE CLAMP #16 WORM GEAR S/S	2

REVISIONS			
REV	DESCRIPTION	DATE	APPROVED
A	INITIAL RELEASE	11/22/2019	TWL

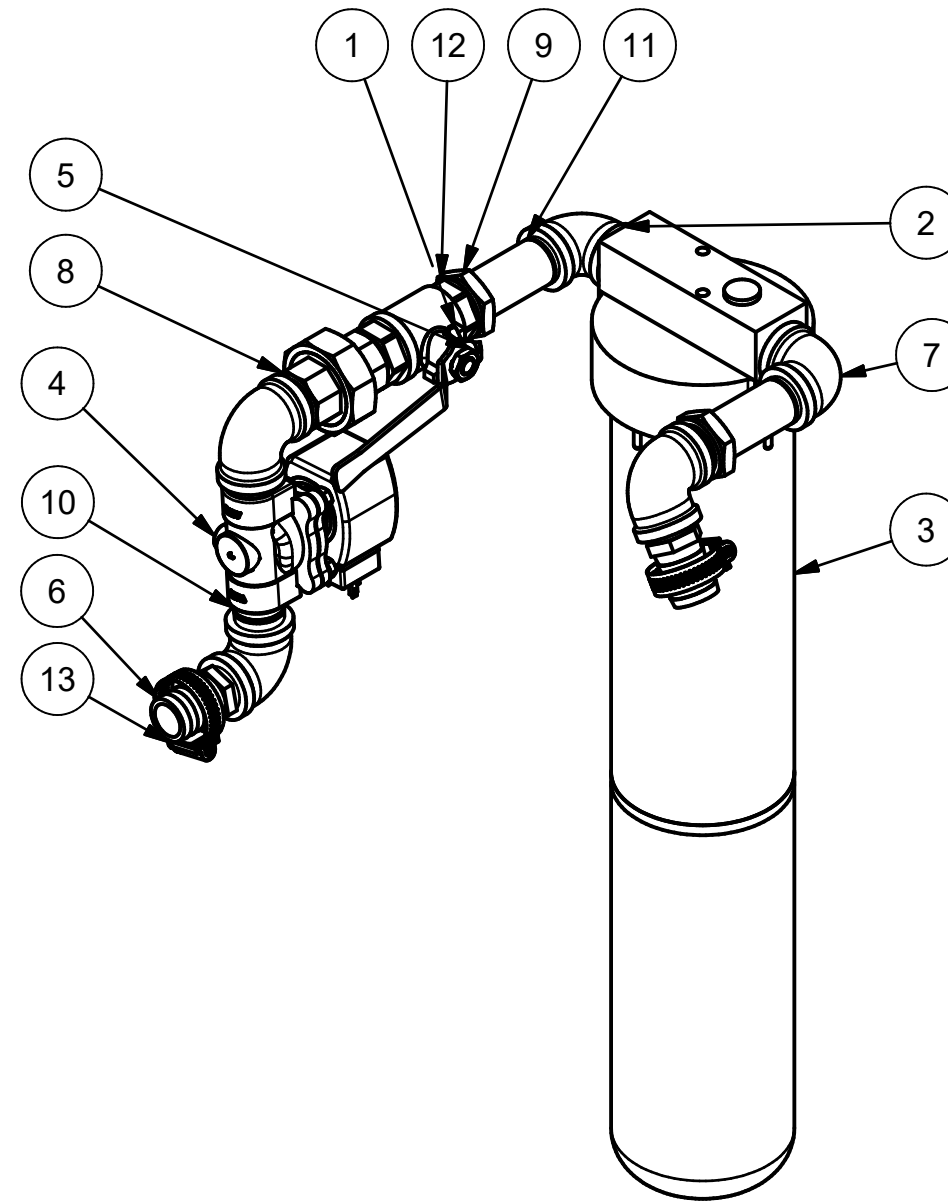

<h1>CV•TEK</h1>	
THIS DRAWING IS THE PROPERTY OF CV•TEK, INC. AND IS TO BE CONSIDERED CONFIDENTIAL. USE OR REPRODUCTION WITHOUT THE EXPRESS PERMISSION OF THE COMPANY IS STRICTLY PROHIBITED.	APPROVED MFG: MDS APPROVED ENG: MDS
DRAWN BY: TomJr	TITLE: MAP VAC LONG CUNO ASSEMBLY WITH VALVE
TOLERANCES: UNLESS OTHERWISE STATED: FRACTIONAL = ± .015 XX = ± .015 XXX = ± .005 XXXX = ± .0005 DRILLED HOLE: STANDARD S.A.E.	DWG NO.: MA185-0008
SCALE: N/A	DATE: 10/14/2021
	SHEET 1 OF 1

PARTS LIST			
ITEM	PART NO.	DESCRIPTION	QTY
1	74103301	1 X 3/4 NPT MALE HOSE BARB	1
2	74300801	3/4 NPT FEMALE ELBOW, CAST BRASS	3
3	74303401	3/4 CLOSE NIPPLE	2
4	72201201	HEAD, CUNO FILTER, BLUE ACETAL	1
5	74305701	3/4 X 4 NIPPLE W/2-1/2 EXTENDED THREAD ON ONE END, BRASS	2
6	74303001	3/4 LOCKNUT BRASS EXTRUDED	2
7	75001701	HOSE CLAMP #16 WORM GEAR S/S	1
8	62200201	CUNO SUMP ONLY, 1M2 FILTER UNIT, 23.2/590MM, TRANSPARENT	1
9	71601101	3/4 SEAL RING	2
10	72202101	Wrench; for Cuno Sump	1

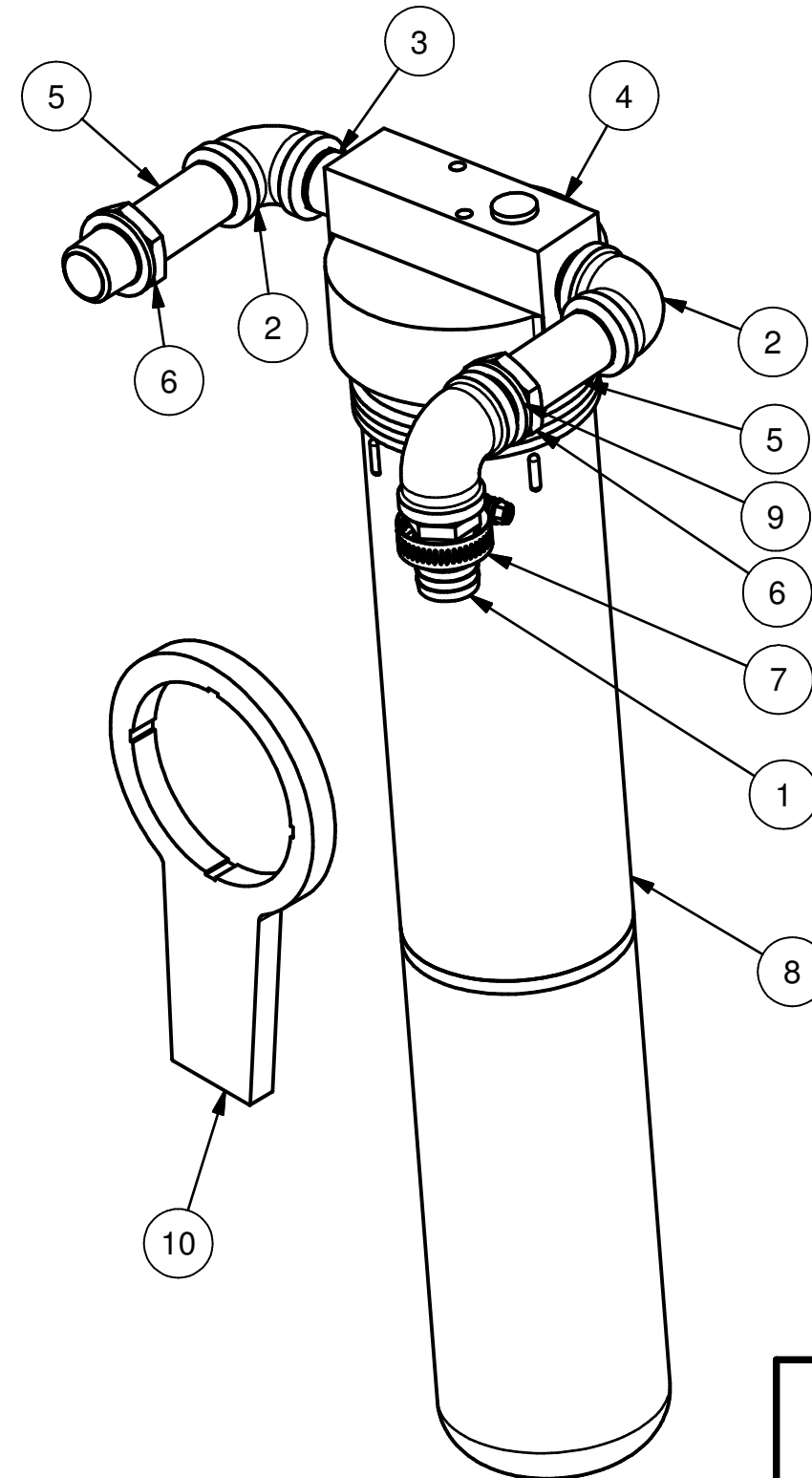

REVISIONS			
REV	DESCRIPTION	DATE	APPROVED
A	INITIAL RELEASE		N.B
B	ADDED NOTE	4/12/2024	PV
C	NEW WASHER 71601101	11/11/2024	VK

USE WITH PIAB THAT HAS SEVERE SERVICE VALVE



**NOTE:** FOR EACH ASSEMBLY, ADDITIONALLY USE:

**OPTION 1:** 1 INCH 45 DEG COPPER ELBOW (PART #74400101) OR

**OPTION 2:** TWO KUNO PAPER FILTERS (PART #72200401) AND A BLUE STICK

<h1>CV•TEK</h1>	
THIS DRAWING IS THE PROPERTY OF CV•TEK, INC. AND IS TO BE CONSIDERED CONFIDENTIAL. USE OR REPRODUCTION WITHOUT THE EXPRESS PERMISSION OF THE COMPANY IS STRICTLY PROHIBITED.	APPROVED MFG: _____ APPROVED ENG: _____
TOLERANCES: UNLESS OTHERWISE STATED: FRACTIONAL = ± .015 XX = ± .015 .XXX = ± .005 XXXX = ± .0005 DRILLED HOLE: STANDARD S.A.E.	DRAWN BY: rowdy
	TITLE: <b>MK 3 LONG CUNO ASSEMBLY NO VALVES</b>
	DWG NO.: <b>MA185-0015</b>
SCALE: N/A	DATE: 1/31/2023
	SHEET 1 OF 1

REVISION			
REV	DESCR	DATE	APRVD
A	INITIAL RELEASE	4/11/2022	PV
B	REPLACED 74203101 WITH 110556C1	8/14/24	RB
C	REPLACED BALL VALVE 110608C1 WITH 73103601	11/12/2024	VK

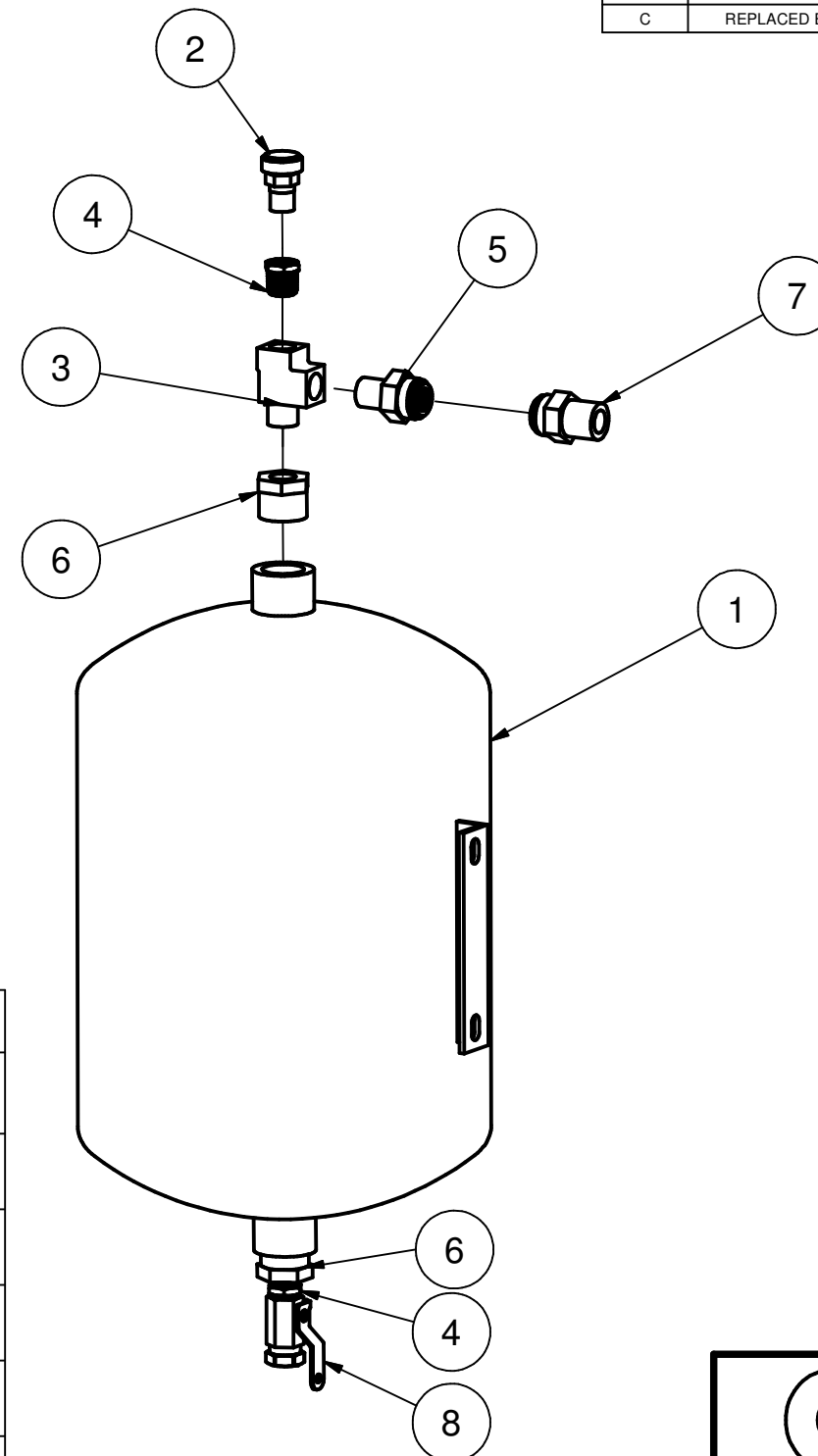

Parts List

ITEM	QTY	PART NUMBER	DESCRIPTION
1	1	73000101	GAS ACCUMULATOR TANK, S/S, 9 O.D. 7.25 CUBIC INCHES
2	1	73103401	PRESSURE RELIEF VALVE W/1/4 NPT THREAD
3	1	74306001	3/8 NPT MALE RUN TEE
4	2	74302201	3/8M X 1/4F hex head bushing
5	1	74203101	1/2 OD TUBE X 3/8 NPT MALE CONNECTOR, PLASTIC
6	2	74302601	3/4 NPT MALE x 3/8 NPT FEMALE HEX HEAD BUSHING, BRASS
7	1	110556C1	1/2 NPT AMLE X 1/2 STEM ADAPTER SWIVEL
8	1	73103601	BALL VALVE, 1/4 NPT, 2-WAY, BRASS

# CV•TEK

THIS DRAWING IS THE PROPERTY OF CV TEK, INC. AND IS TO BE CONSIDERED CONFIDENTIAL. USE OR REPRODUCTION WITHOUT THE EXPRESS PERMISSION OF THE COMPANY IS STRICTLY PROHIBITED.

APPROVED MFG: \_\_\_\_\_ APPROVED ENG: \_\_\_\_\_

DRAWN BY: PV

TITLE: **MK III & MAPVAC GAS ACCUMULATOR TANK ASSEMBLY**

TOLERANCES: UNLESS OTHERWISE STATED:  
 NOMINAL = ±.1  
 .XX = ±.1  
 .XXX = ±.01  
 .XXXX = ±.005  
 DRILLED HOLE: STANDARD ISO

DWG NO.: **131457C1**

SCALE: N/A

DATE: 4/10/2022

SHEET 1 OF 1

C

PARTS LIST			
ITEM	PART NO.	DESCRIPTION	QTY
1	109065C1	5/16 FLAT WASHER, 0.570 O.D., 0.07 THCK, S/S	4
2	120747C1	END COVER, L: 65.4 MM, W: 2.2 MM, H: 47.5 MM, COLOR: GRAY	1
3	120751C1	1 TIER PE FEED THROUGH TERMINAL BLOCK	1
4	120752C1	END CLAMP, WIDTH: 9.5 MM, COLOR: GRAY	2
5	122066C1	40 CFM PUMP MOUNT BASE	1
6	125081C1	28 CFM VACUUM PUMP	1
7**	71401001	Fuse 6 amp type aM	3
8	71404701	MINI CONTACTOR 24VAC	1
9**	71405201	LOVATO OVERLOAD 3.0-5.0 AMP	1
10	72104101	ALUMINUM JAR, VACUUM FILTER, 32 OZ	1
11	72106101	FILTER HEAD 3/4 NPT	1
12	74103301	1 X 3/4 NPT MALE HOSE BARB	2
13	74300801	3/4 NPT FEMALE ELBOW, CAST BRASS	1
14	74302701	1 NPT MALE X 3/4 NPT FEMALE HEX HEAD BUSHING	1
15	74304001	1/2 HEX NIPPLE	1
16	74304201	3/4 NPT STREET ELBOW, CAST	2
17	74305201	3/4 X 5 long nipple	1
18	74305401	3/4F X 1/2F FEMALE REDUCER COUPLING	1
19	74305501	3/4 NPT STREET ELBOW, 45 DEG., FORGED BRASS	1
20	74307601	3/4 X 3-1/2 LONG NIPPLE	1
21	75001902	VIBRATION ISOLATION PAD	5
22	75102701	5/16 MED SPLIT LOCK WASHERS, S/S	8
23	75102901	5/16-18 HEX NUT, S/S	8
24	75107601	5/16-18 X 3/4 LNG HEX HEAD CAP SCREW, S/S	4
25	71500401	FAN, ROUND 6.75 24VDC	1
26	71500701	GUARD, FAN	1
27	71500601	CORD; 16/4 SO; BLACK 600V 5.5'	1
28	71605101 1	.20-.35 DIA. CORD GRIP, 1/2 NPT	1
29	71605301	1/2" LOCK NUT	1
30	123250C1	EXHAUST DUCT, MARK III PYLON WELDMENT	1
31	72102001	GASKET, FILTER / EXHST HEAD AA405	1

\*\* REPLACE WITH PART# FOR VOLTAGE  
\* NOT PICTURED

122067C1 PN REPLACEMENT VANES

VOLTAGE	FUSE F1	FUSE F2	FUSE F3	MOTOR STARTER OL SETTINGS **
208-240 VAC 3 PHASE 50/60HZ	71402501 16 AMP	71402501 16 AMP	71402501 16 AMP	71405401 TBD
440-480 VAC 3 PHASE 60HZ	71401001 6 AMP	71401001 6 AMP	71401001 6 AMP	71405201 TBD

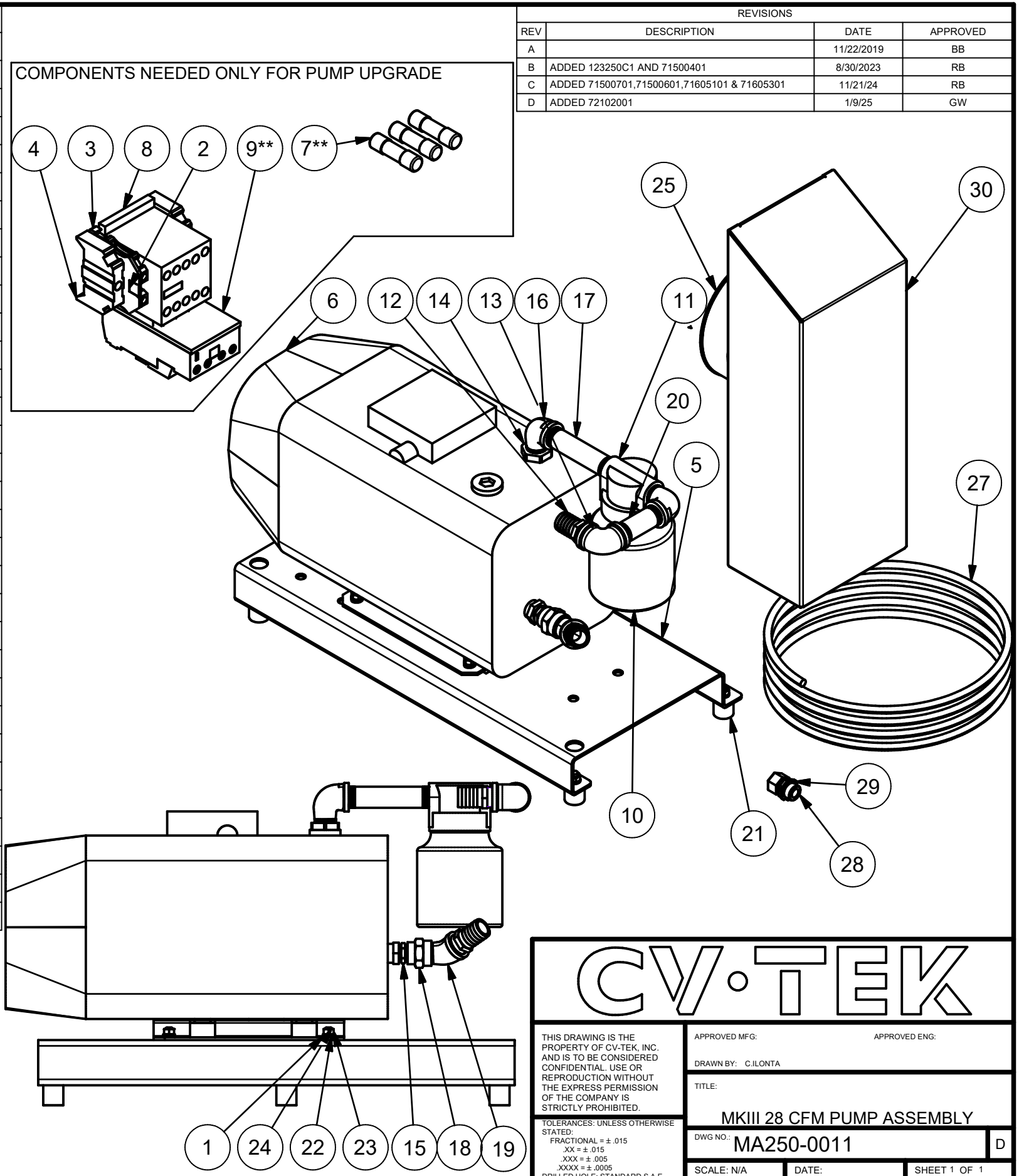

PARTS LIST			
ITEM	PART NO.	DESCRIPTION	QTY
1	72105602	PIAB PUMP ALL PLASTIC, AIR DRIVEN, NO FITTINGS	1
2	73102401	ASCO VALVE, 3/4 NPT BRASS N.C. 24 VAC	1
3	74103201	3/4 X 3/4 MALE HOSE BARB	1
4	74103301	1 X 3/4 NPT MALE HOSE BARB	1
5	74204201	3/8 O.D. TUBE X 1/4 NPT FIXED ELBOW, MALE, PLASTIC	1
6	74300801	3/4 NPT FEMALE ELBOW, CAST BRASS	1
7	74301501	3/4 UNION, CAST	1
8	74301701	1/4 plug, hex countersunk	1
9	74304101	3/4 NPT HEX NIPPLE, BRASS	1
10	74305001	3/4 NPT X 3 LONG NIPPLE, BRASS	1
11	74305501	3/4 NPT STREET ELBOW, 45 DEG., FORGED BRASS	1
12	71607403	ASCO VALVE PLUG CABLE 18mm 3m	1
13	269P-08-08	FITTING.ELB.1/2 NPT TO 1/2 OD	1

REVISIONS			
REV	DESCRIPTION	DATE	APPROVED
A	INITIAL RELEASE	06/06/2018	CI
B	ADDED 71607403 & 269P-08-08 , REPLACED 72105601 WITH 72105602	11/15/24	RB

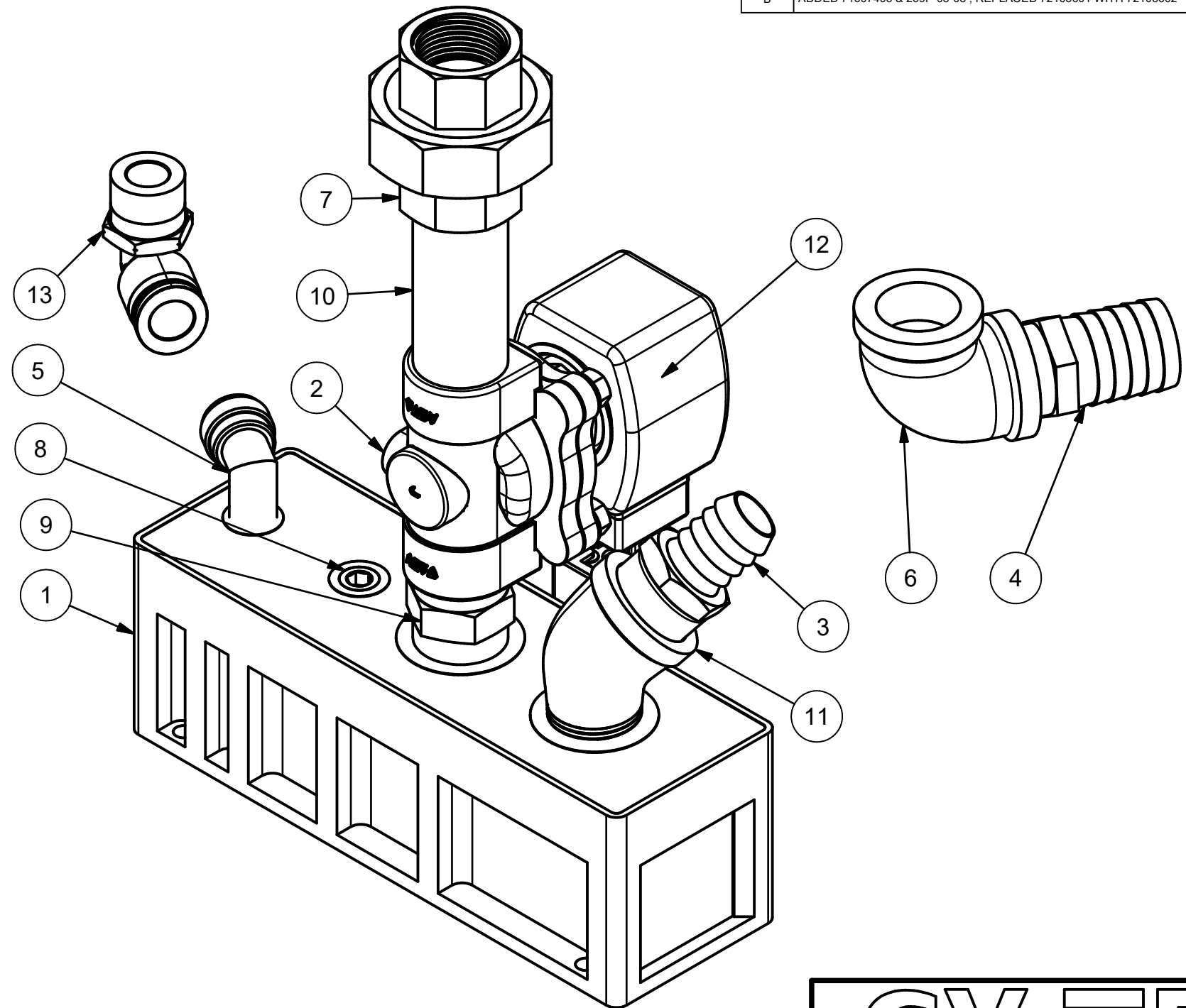

<h1>CV•TEK</h1>	
THIS DRAWING IS THE PROPERTY OF CV•TEK, INC. AND IS TO BE CONSIDERED CONFIDENTIAL. USE OR REPRODUCTION WITHOUT THE EXPRESS PERMISSION OF THE COMPANY IS STRICTLY PROHIBITED.	APPROVED MFG: _____ APPROVED ENG: _____
TOLERANCES: UNLESS OTHERWISE STATED: FRACTIONAL = ± .015 XX = ± .015 XXX = ± .005 XXXX = ± .0005 DRILLED HOLE: STANDARD S.A.E.	DRAWN BY: C.ILONTA TITLE: <b>MK3 AIR DRIVEN PUMP</b>
SCALE: N/A	DATE: _____ SHEET 1 OF 1

B

PARTS LIST			
ITEM	PART NO.	DESCRIPTION	QTY
1	108586C1	1/4-20 X 5/8 LNG HEX HEAD CAP SCREW, S/S	4
2	109091C1	5/16-18 X 1-1/2 LNG HEX HEAD CAP SCREW, S/S	4
3	110221C1	#10-24 X 3/8 LNG HEX HEAD MACHINE SCREW, S/S	1
4	120747C1	END COVER, L: 65.4 MM, W: 2.2 MM, H: 47.5 MM, COLOR: GRAY	1
5	120751C1	1 TIER PE FEED THROUGH TERMINAL BLOCK; AWG:26-12; W:5.2MM; GRN/YEL	1
6	120752C1	END CLAMP, WIDTH: 9.5 MM, COLOR: GRAY	2
7	124800C1	MK3 WATER RING PUMP TANK SUPPORT	1
8**	71401001	Fuse 6 amp type aM	3
9	71404701	MINI CONTACTOR 24VAC	1
10**	71405201	LOVATO OVERLOAD 3.0-5.0 AMP	1
11	71604801	CORD GRIP, .375-.437, 3/4 WOOD	1
12	71607403	ASCO VALVE PLUG CABLE 18mm 3m	1
13	72111401	WATER RING PUMP 60	1
14	73107301	1/2 NPT, .75 GPM, EPR Seal, PVC Flow Control Valve	1
15	73107501	Valve, 1/2 NPT brass N.C. 24VAC w/ DIN	1
16	74000101	PVC Y-Strainer 1/2 NPT Pipe 150 psi	1
17	74000301	Locking Nylon Pipe Hanger 3/4 to 7/8 O.D. Pipe, 9/16 High X 1 Inch Wide	1
18	74303701	1/4 NPT hex nipple - long	1
19	74500101	1/2 NPT Male X 1/4 NPT Female Reducing Hex Bushing Schedule 80, Dark Gray PVC	1
20	74500201	1/2 NPT Female X 1/2 NPT Female 90 Degree Elbow Schedule 80 Dark Gray PVC	3
21	74500301	1/2 NPT X 1/2 NPT X 2 Inch Long Threaded Pipe Nipple Schedule 80 Dark Gray PVC	1
22	74500401	1/2 NPT X 1/2 NPT X 1-1/8 INCH LONG THREADED PIPE NIPPLE GREY PVC	4
23	74500601	Adapter 1/2 Inch Barbed (.635 O.D.) X 1/2 NPT Male Schedule 80 Dark Gray PVC	3
24	74500701	1/2 NPT Female Bulkhead Fitting 1/2 NPT Female X 1/2 NPT Female Gray PVC 1-3/8 Inch Hole Required	1
25	74500801	1/2 NPT Female Ball Valve Schedule 80 Gray CPVC Vito O-Rings	1
26	74500901	1-1/4M NPT X 1F NPT REDUCING HEX BUSHING PVC	2
27	74501001	1 NPT X 1 NPT X 1-1/2 THREADED PIPE CLOSE NIPPLE PVC	1
28	74501101	1 NPT Female X 1 NPT Female 45 Degree Elbow Schedule 80 Dark Gray PVC	1
29	74501201	1" BARBED X 1 NPT MALE ADAPTER PVC	4
30	74501301	1 NPT X 1 NPT Female Bulkhead Fitting Gray PVC, 1-7/8 Inch Hole Diameter Required	1
31	74501801	Water and Air Separator Weldment (PVC)	1
32	74501901	1/2 NPT X 1/2 NPT X 3 Inch Long Threaded Pipe Nipple Schedule 80 Dark Gray PVC	1
33	75001701	HOSE CLAMP #16 WORM GEAR S/S	2
34	75003201	HOSE CLAMP, #8 WORM GEAR S/S	2
35	75102701	5/16 MED SPLIT LOCK WASHERS, S/S	4
36	75102801	#10 FLAT WASHER, 0.438 O.D., 0.04 THCK, S/S	4
37	75102901	5/16-18 HEX NUT, S/S	4
38	75103101	5/16 FLAT WASHER, 0.750 O.D., 0.06 THCK, S/S	8
39	75103301	1/4 FLAT WASHER, 0.625 O.D., 0.06 THCK, S/S	8
40	75103801	1/4-20 HEX NUT, S/S	4
41	75110701	#10-32 X 1/2 LNG HEX HEAD MACHINE SCREW, S/S	2
42	75112501	3/8-16 X 1/2 LNG HEX HEAD CAP SCREW, S/S	1
43	75118601	#10-32 HEX NUT, S/S	4
44	76000401A	PIPE HANGER SUPPORT BRACKET FOR LEM60 WATER-RING PUMP	1
45	76000701A	Pipe Hanger Mounting Bracket LEM60 Water-Ring Pump	1
46	76209901	MKII COVER EXHAUST PORT WATER RING PUMP	1
47	79501701	PVC VIBRATION MOUNTS	4
48	84400101	1 Inch NPT Close 304/304L Stainless Steel Pipe Nipple, 1-1/2 Inch Long	1
49*	73302501	TUBING, 5/8 POLYWIRE	1 FT
50*	73301501	TUBING, 1 POLYWIRE	1.5 FT
51*	71604502	CORD 16/4 SOOW BLACK	6 FT

REVISIONS			
REV	DESCRIPTION	DATE	APPROVED
A	INITIAL RELEASE	02/22/2016	N.B
B	ADDED 74501201 X1	2/6/2024	RB

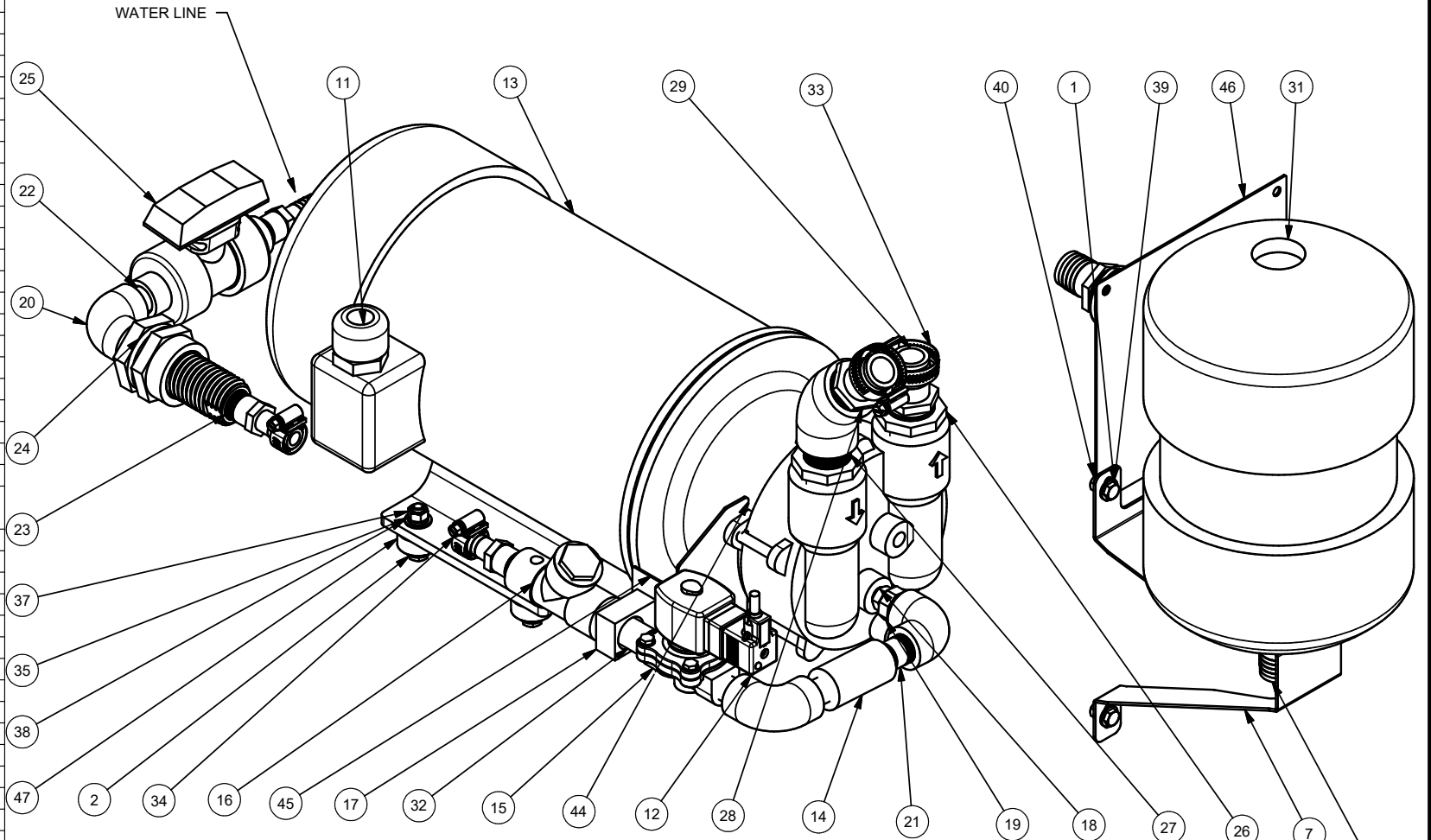

\* NOT PICTURED  
 \*\* REPLACE WITH PART# FOR VOLTAGE

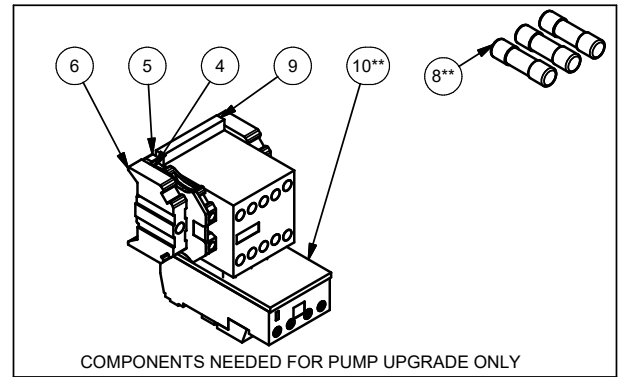

VOLTAGE	FUSE F1	FUSE F2	FUSE F3	MOTOR STARTER OL SETTINGS **
208-240 VAC 3 PHASE 50/60HZ	71402501 16 AMP	71402501 16 AMP	71402501 16 AMP	71405401 8.5
440-480 VAC 3 PHASE 60HZ	71401001 6 AMP	71401001 6 AMP	71401001 6 AMP	71405201 3.9

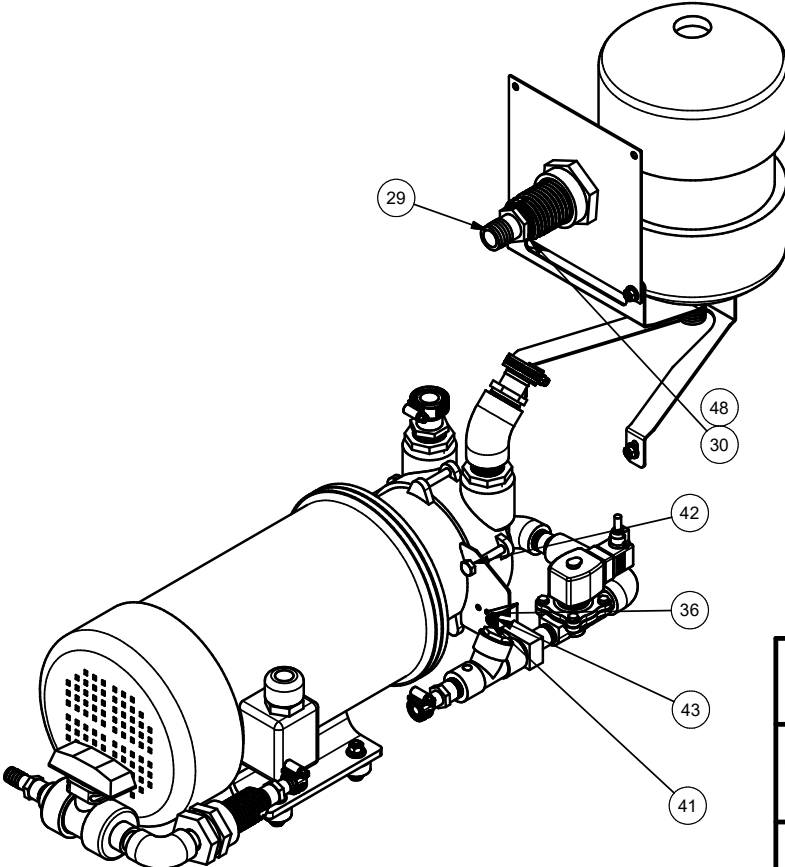

THIS DRAWING IS THE PROPERTY OF M-TEK, INC. AND IS TO BE CONSIDERED CONFIDENTIAL. USE OR REPRODUCTION WITHOUT THE EXPRESS PERMISSION OF THE COMPANY IS STRICTLY PROHIBITED.

APPROVED MFG: \_\_\_\_\_ APPROVED ENG: \_\_\_\_\_  
 DRAWN BY: C.LONTA  
 TITLE: **MK3 38 CFM WATER RING PUMP**  
 DWG NO: MA250-0017  
 SCALE: N/A DATE: 1/14/2016 SHEET 1 OF 1

VOLTAGE	FUSE F1	FUSE F2	FUSE F3	MOTOR STARTER OL SETTINGS **
208-240 VAC 3 PHASE 50/60HZ	71401201 10 AMP	71401201 4 AMP	71401201 4 AMP	71405301 6.0
440-480 VAC 3 PHASE 60HZ	71401001 6 AMP	71401001 6 AMP	71401001 6 AMP	71405201 3.0

\*\* REPLACE WITH PART# FOR VOLTAGE  
\* NOT PICTURED

REVISIONS			
REV	DESCRIPTION	DATE	APPROVED
A	INITIAL RELEASE	06/18/2018	CI
B	ADDED 123250C1 AND 71500401 TO BOM	8/30/23	RB
C	ADDED CORD GRIP 71604801	1/24/24	RB
D	ADDED 71500701, 71500601 & 71605101	11/21/24	RB
E	UPDATED BOM TO MATCH INFOR	1/3/2025	GW

PARTS LIST

ITEM	PART NO.	DESCRIPTION	QTY
1	120747C1	END COVER, L: 65.4 MM, W: 2.2 MM, H: 47.5 MM, COLOR: GRAY	1
2	120751C1	1 TIER PE FEED THROUGH TERMINAL BLOCK	1
3	120752C1	END CLAMP, WIDTH: 9.5 MM, COLOR: GRAY	2
4	71401001	Fuse 6 amp type aM	3
5	71404701	MINI CONTACTOR 24VAC	1
6	71405201	LOVATO OVERLOAD 3.0-5.0 AMP	1
7	72106501	BUSCH 28 CFM PUMP, STANDARD	1
8	73103601	BALL VALVE, 1/4 NPT, 2-WAY, BRASS	1
9	74103301	1 X 3/4 NPT MALE HOSE BARB	4
10	74300801	3/4 NPT FEMALE ELBOW, CAST BRASS	3
11	74301701	1/4 plug, hex countersunk	1
12	74302201	3/8M X 1/4F hex head bushing	1
13	74302301	1/2 NPT MALE x 3/8 NPT FEMALE HEX HEAD BUSHING, BRASS	1
14	74303801	1-1/4M X 3/4 HEX HEAD BUSHING	2
15	74304501	3/8 STREET ELBOW	1
16	74305001	3/4 NPT X 3 LONG NIPPLE, BRASS	1
17	74305501	3/4 NPT STREET ELBOW, 45 DEG., FORGED BRASS	1
18*	71604502	CORD 16/4 SOOW BLACK	6 FT
19*	123250C1	EXHAUST DUCT WELDMENT	1
20*	71500401	FAN; ROUND 6.75 24DC	1
21*	71500701	Guard; fan 6.7 DC fan	1
22*	71500601	Fan cord; 6.7 dc fan	1
23*	71605101	CORD GRIP; .20-.35 1/2 NPT	1
24	71604801	CORD GRIP, .375-.437, 3/4 WOOD	1
25*	71605201	CORD GRIP, .35 - .47 DIA., 1/2 NPT GREY	1

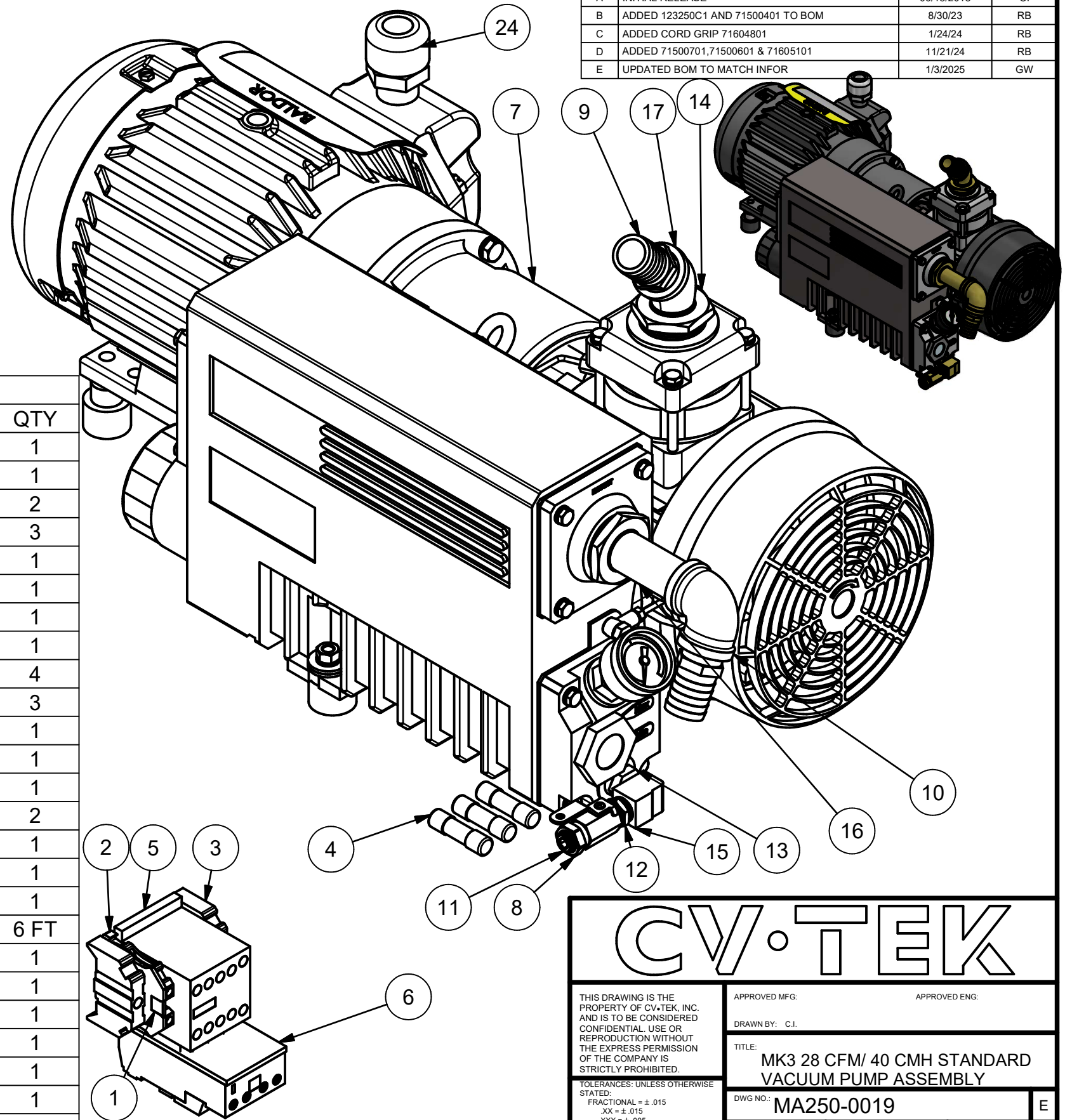

**CV-TEK**

THIS DRAWING IS THE PROPERTY OF CV-TEK, INC. AND IS TO BE CONSIDERED CONFIDENTIAL. USE OR REPRODUCTION WITHOUT THE EXPRESS PERMISSION OF THE COMPANY IS STRICTLY PROHIBITED.

TOLERANCES: UNLESS OTHERWISE STATED:  
 FRACTIONAL = ± .015  
 .XX = ± .015  
 .XXX = ± .005  
 .XXXX = ± .0005  
 DRILLED HOLE: STANDARD S.A.E.

APPROVED MFG: \_\_\_\_\_ APPROVED ENG: \_\_\_\_\_  
 DRAWN BY: C.I.  
 TITLE: MK3 28 CFM/ 40 CMH STANDARD VACUUM PUMP ASSEMBLY  
 DWG NO.: MA250-0019  
 SCALE: N/A DATE: \_\_\_\_\_ SHEET 1 OF 1

COMPONENTS NEEDED ONLY FOR PUMP UPGRADE

REVISIONS			
REV	DESCRIPTION	DATE	APPROVED
A	INITIAL RELEASE	06/18/2018	N.B
B	ADDED 123250C1 AND 71500401	8/30/23	RB
C	ADDED CORD GRIP 71604801	1/24/24	RB
D	UPDATED TITLE BLOCK	1/9/2025	GW

VOLTAGE	FUSE F1	FUSE F2	FUSE F3	MOTOR STARTER OL SETTINGS **
208-240 VAC 3 PHASE 50/60HZ	71401201 10 AMP	71401201 4 AMP	71401201 4 AMP	71405301 6.0
440-480 VAC 3 PHASE 60HZ	71401001 6 AMP	71401001 6 AMP	71401001 6 AMP	71405201 3.0

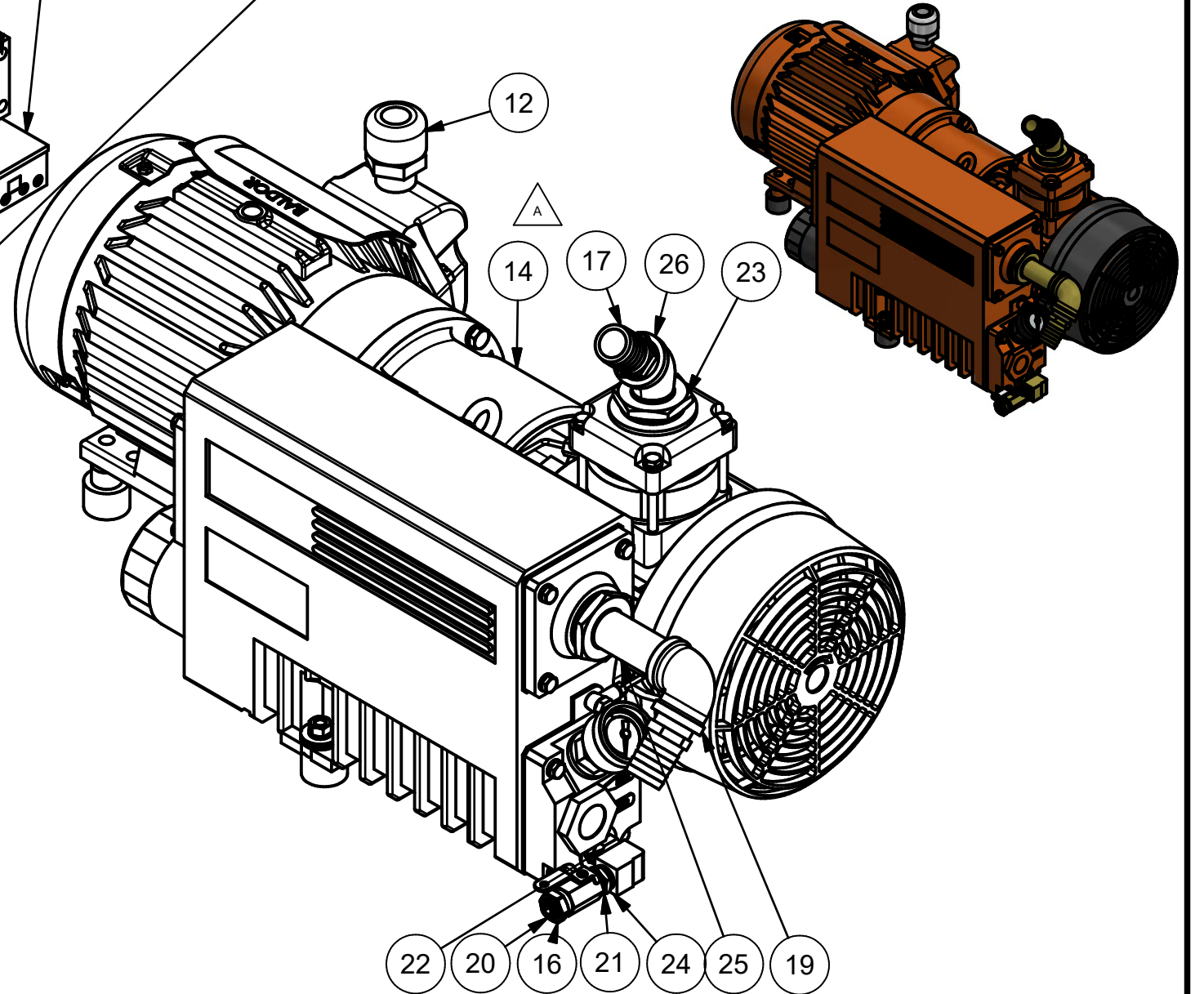
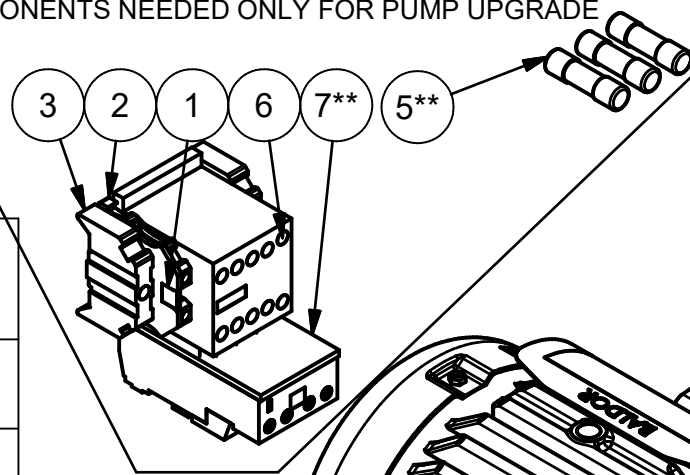

PARTS LIST

ITEM	PART NO.	DESCRIPTION	QTY
1	120747C1	END COVER, L: 65.4 MM, W: 2.2 MM, H: 47.5 MM, COLOR: GRAY	1
2	120751C1	1 TIER PE FEED THROUGH TERMINAL BLOCK; AWG:26-12; W:5.2MM; GRN/YEL	1
3	120752C1	END CLAMP, WIDTH: 9.5 MM, COLOR: GRAY	2
4*	123250C1	EXHAUST DUCT WELDMENT	1
5**	71401001	Fuse 6 amp type aM	3
6	71404701	MINI CONTACTOR 24VAC	1
7**	71405201	LOVATO OVERLOAD 3.0-5.0 AMP	1
8*	71500401	FAN; ROUND 6.75 24VDC	1
9*	71500601	Fan cord; 6.7 dc fan	1
10*	71500701	Guard; fan 6.7 DC fan	1
11	71604502	CORD 16/4 SOOW BLACK	6 FT
12	71604801	CORD GRIP, .375-.437, 3/4 WOOD	1
13*	71605101	CORD GRIP; .20-.35 1/2 NPT	1
14	72105501	BUSCH 28 CFM / 40 CMH O2 VACUUM PUMP, OXIGEN RATED	1
15*	72202101	Wrench; for Cuno sump	1
16	73103601	BALL VALVE, 1/4 NPT, 2-WAY, BRASS	1
17	74103301	1 X 3/4 NPT MALE HOSE BARB	4
18*	74203001	3/8 X 1/4 male conn. plastic	1
19	74300801	3/4 NPT FEMALE ELBOW, CAST BRASS	3
20	74301701	1/4 plug, hex countersunk	1
21	74302201	3/8M X 1/4F hex head bushing	1
22	74302301	1/2 NPT MALE x 3/8 NPT FEMALE HEX HEAD BUSHING, BRASS	1
23	74303801	1-1/4M X 3/4 HEX HEAD BUSHING	2
24	74304501	3/8 STREET ELBOW	1
25	74305001	3/4 NPT X 3 LONG NIPPLE, BRASS	1
26	74305501	3/4 NPT STREET ELBOW, 45 DEG., FORGED BRASS	1

**MUST BE O2 CLEANED**

\*\* REPLACE WITH PART# FOR VOLTAGE  
\*NOT PICTURED

**CV-TEK**

THIS DRAWING IS THE PROPERTY OF CV-TEK, INC. AND IS TO BE CONSIDERED CONFIDENTIAL. USE OR REPRODUCTION WITHOUT THE EXPRESS PERMISSION OF THE COMPANY IS STRICTLY PROHIBITED. TOLERANCES: UNLESS OTHERWISE STATED: FRACTIONAL = ± .015 XX = ± .015 .XXX = ± .005 .XXXX = ± .0005 DRILLED HOLE: STANDARD S.A.E.	APPROVED MFG:	APPROVED ENG:
	DRAWN BY: C.LONTA	
	TITLE: MK3 28 CFM / 40 CMH O2 VACUUM PUMP OXIGEN RATED, ASSEMBLY	
	DWG NO.: MA250-0020	D
SCALE: N/A	DATE:	SHEET 1 OF 1

REVISIONS			
REV	DESCRIPTION	DATE	APPROVED
A	INITIAL RELEASE		N.B

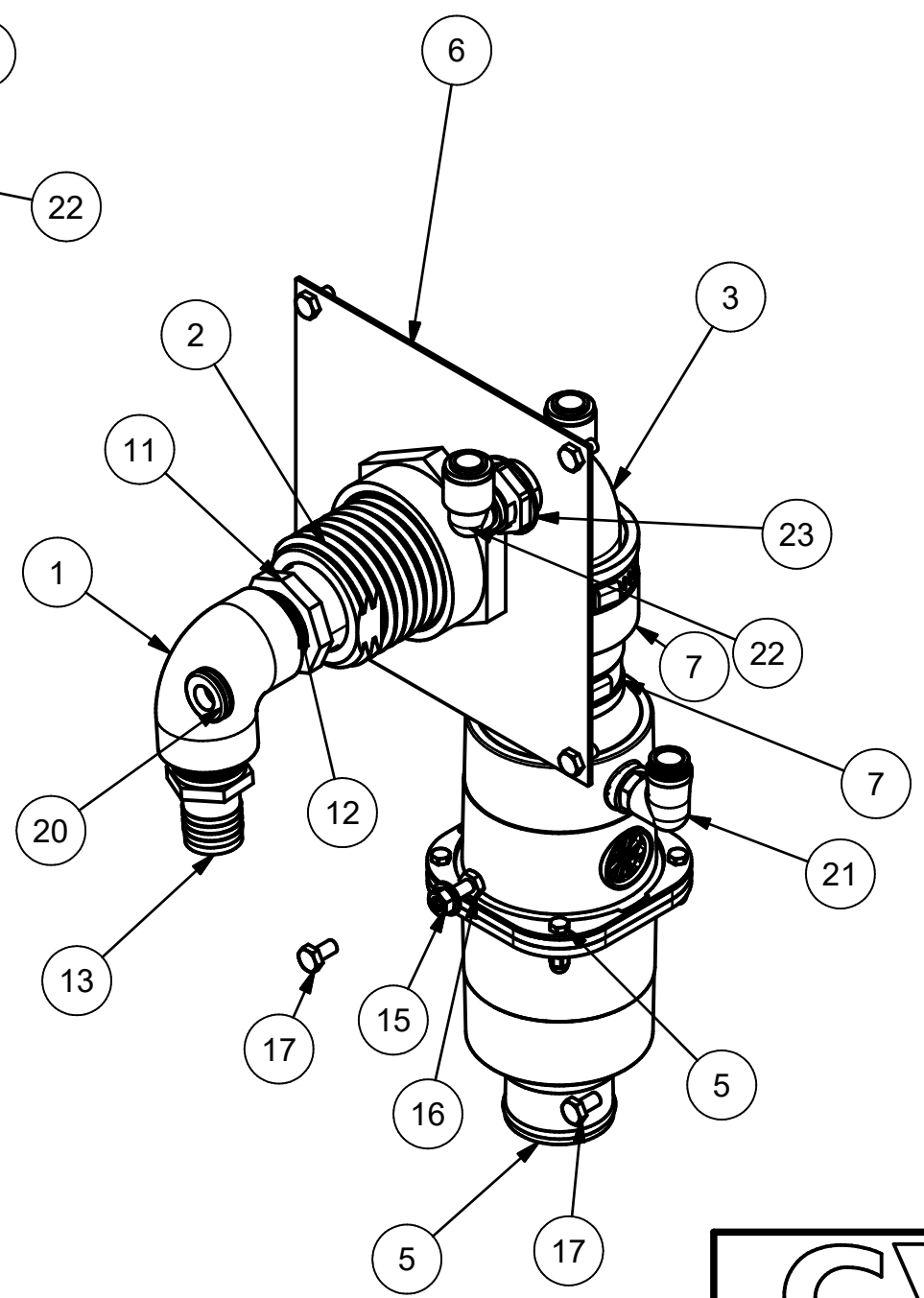
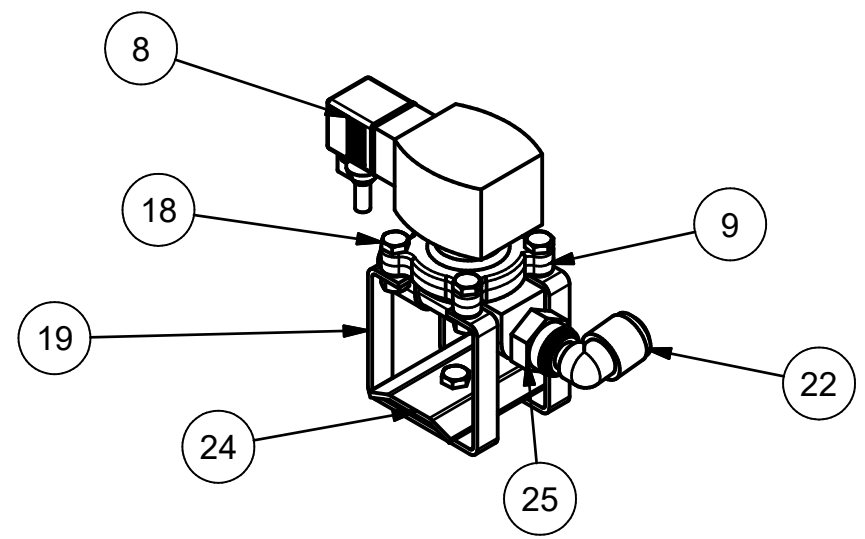

PARTS LIST

ITEM	PART NO.	DESCRIPTION	QTY
1	121178C1	THICK WALL 90 DEG ELBOW THREADED PIPE 1 NPT	1
2	121820C1	THROUGHT WALL FITTING PVC, FEM, NPT, 1-1/4"	1
3	121898C1	90 Deg THREADED ELBOW, 1-1/4 NPTF PVC	1
4	121899C1	GRAY PVC FULLY THREADED NIPPLE, 1-1/4 NPT, SCHEDULE 80	1
5	122904C1	PUMP, VACUUM, ROUND COAX CARTRIDGE STYLE	1
6	123248C1	PIAB ADAPTER PLATE	1
7	123964C1	PIAB PUMP 2" X 1 1/2" COUPLING	1
8	71607403	ASCO VALVE PLUG CABLE 18mm 3m	1
9	73103701	3/8 NPT BRASS N.C. 24 VAC	1
10	74203201	3/8 NPT MALE X 3/8 O.D. TUBE	1
11	74500901	1-1/4M NPT X 1F NPT REDUCING HEX BUSHING PVC	1
12	74501001	1 NPT X 1 NPT X 1-1/2 THREADED PIPE CLOSE NIPPLE PVC	1
13	74501201	1" BARBED X 1 NPT MALE ADAPTER PVC	1
14	75103301	1/4 FLAT WASHER, 0.625 O.D., 0.06 THCK, S/S	2
15	75103801	1/4-20 HEX NUT, S/S	6
16	75106401	1/4-20 X 3/4 LNG HEX HEAD CAP SCREW, S/S	1
17	75109501	1/4-20 X 1/2 LNG HEX HEAD CAP SCREW, S/S	7
18	75109601	1/4-20 X 7/8 LNG HEX HEAD CAP SCREW, S/S	4
19	76204401A	STAND OFF MAC VALVE	2
20	79501501	RUBBER GROMMET 1/2 ID HOLE, 3/32 GROOVE WIDTH, 1.0 OD	1
21	74103001	1/2 X 3/8 Parker Male Elbow	1
22	110517C1	1/2 MALE TUBE O.D. x 1/2 TUBE PLUG IN ELBOW, PLASTIC	3
23	110508C1	1/2 BLKHD UNION PLASTIC	1
24	76204500	Plate, Mac hold down plate for stand off	1
25	74203101	1/2 O.D. TUBE X 3/8 NPT MALE CONNETOR, PLASTIC	1

## CV•TEK

THIS DRAWING IS THE PROPERTY OF CV•TEK, INC. AND IS TO BE CONSIDERED CONFIDENTIAL. USE OR REPRODUCTION WITHOUT THE EXPRESS PERMISSION OF THE COMPANY IS STRICTLY PROHIBITED.

TOLERANCES: UNLESS OTHERWISE STATED:  
 FRACTIONAL = ± .015  
 XX = ± .015  
 XXX = ± .005  
 XXXX = ± .0005  
 DRILLED HOLE: STANDARD S.A.E.

APPROVED MFG:	APPROVED ENG:
DRAWN BY: BBANGE	
TITLE: MAP VAC PIAB HIGH FLOW PUMP ASSEMBLY	
DWG NO.: MA250-0028	A
SCALE: N/A	DATE:
SHEET 1 OF 1	

PARTS LIST			
ITEM	PART NO.	DESCRIPTION	QTY
1	121302C1	ASHCROFT VACUUM SENSOR	1
2	121501C1	M12 5-5 PIN 90DEGREE 1.5METER BLACK CABLE (FOR ASHCROFT)	1
3	125097C1	3/4 BALL VALVE HANDLE	1
4	74103301	1 X 3/4 NPT MALE HOSE BARB	1
5	74203101	1/2 OD TUBE X 3/8 NPT MALE CONNECTOR, PLASTIC	1
6	74203801	3/8 O.D. TUBE, UNION ELBOW	2
7	74204601	3/8 OD x 1/4 NPT STEM ADAPTER	2
8	74300801	3/4 NPT FEMALE ELBOW, CAST BRASS	2
9	74300901	3/4 NPT FEM TEE FORGED	2
10	74301501	3/4 UNION, CAST	1
11	74302401	3/4 NPT MALE X 1/2 NPT FEMALE HEX HEAD BUSHING	1
12	74303001	3/4 LOCKNUT BRASS EXTRUDED	3
13	74303601	1/2M X 3/8M HEX REDUCER NIPPLE	1
14	74304101	3/4 NPT HEX NIPPLE, BRASS	3
15	74304601	3/4 STREET ELBOW, EXTRUDED	1
16	74304801	1/8 STREET ELBOW	1
17	73108001	CHEMLINE SEVERE SERVICE VALVE	1
18	73103701	3/8 NPT BRASS N.C. 24 VAC	1
19	74309201	3/4 X 3-1/2 Nipple w/1-3/4 Ext	1
20	74200601	1/2 TUBE X 1/2 NPT JACO MALE CONN., PLASTIC	2
21	79200101A	VACUUM Y WHITE DELRIN	1
22	71601101	3/4 SEAL RING	1
23	71607403	ASCO VALVE PLUG CABLE 18mm 3m	1
24	74302101	3/4 plug, hex head	1

REVISIONS			
REV	DESCRIPTION	DATE	APPROVED
A	INITIAL RELEASE	06/27/2018	N.B
B	ITEM 73103701 WAS P/N 73102201	2/27/2023	MS
C	ADDED/REMOVED ITEMS TO MATCH INFOR	11/15/2024	GW

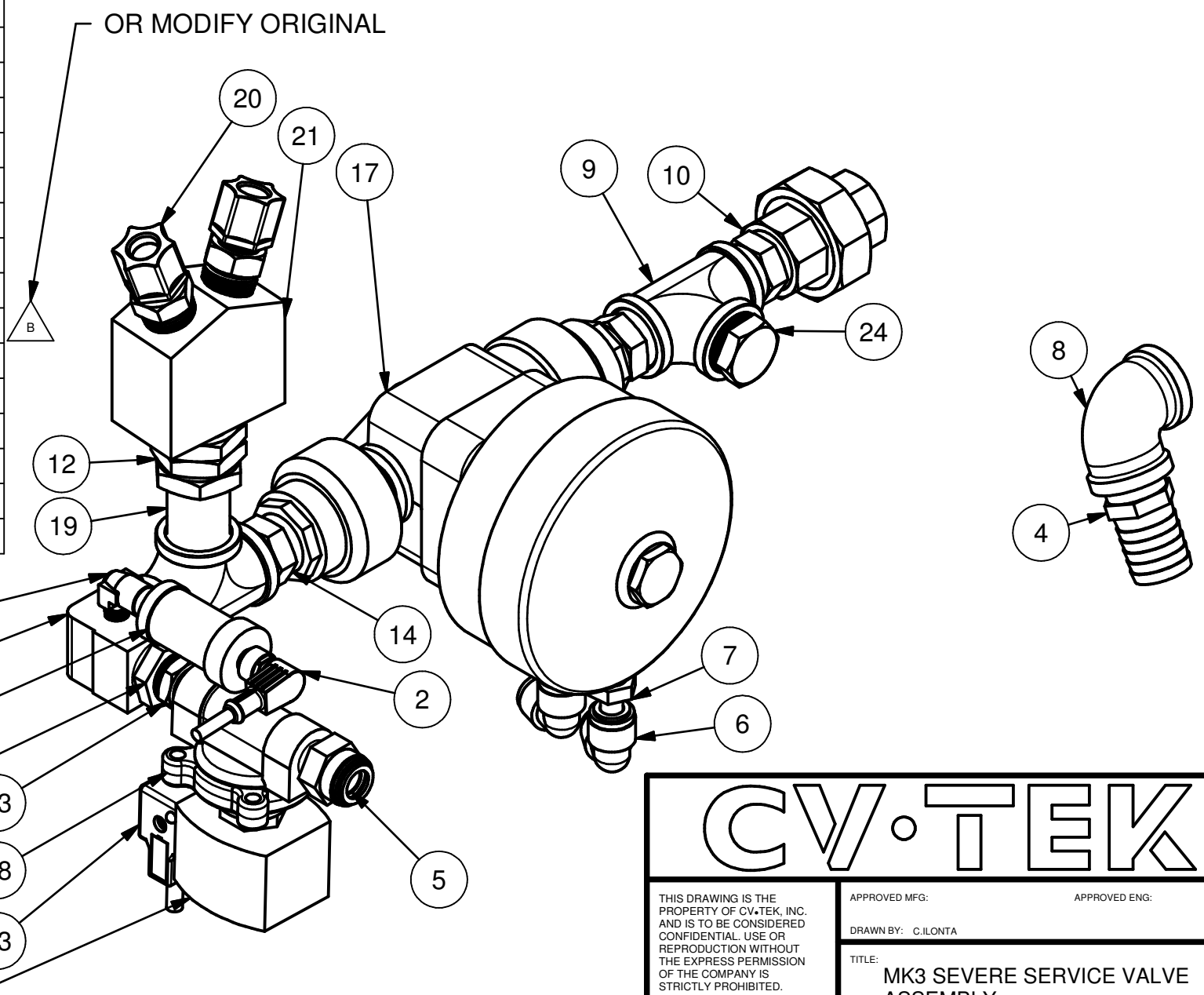

PART NUMBER  
73103801 IF  
O2 CLEANED

## CV•TEK

THIS DRAWING IS THE PROPERTY OF CV•TEK, INC. AND IS TO BE CONSIDERED CONFIDENTIAL. USE OR REPRODUCTION WITHOUT THE EXPRESS PERMISSION OF THE COMPANY IS STRICTLY PROHIBITED.

TOLERANCES: UNLESS OTHERWISE STATED:  
 FRACTIONAL = ± .015  
 XX = ± .015  
 .XXX = ± .005  
 .XXXX = ± .0005  
 DRILLED HOLE: STANDARD S.A.E.

APPROVED MFG:	APPROVED ENG:
DRAWN BY: C.I.LONTA	TITLE: <b>MK3 SEVERE SERVICE VALVE ASSEMBLY</b>
DWG NO.: <b>MA251-0001</b>	<b>C</b>
SCALE: N/A	DATE: _____ SHEET 1 OF 1

PARTS LIST			
ITEM	PART NO.	DESCRIPTION	QTY
1	108586C1	1/4-20 X 5/8 LNG HEX HEAD CAP SCREW, S/S	2
2	108677C1	1/4-20 X 1 LNG HEX HEAD CAP SCREW, S/S	4
3	108679C1	Ø1/4 X 1 DOWEL PIN, S/S	4
4	110544C1	1/4 FLAT WASHER, 0.630 O.D., 0.08 THCK, S/S	10
5	125477C1	FRAME PLATE 54 COMPLETE NEW	1
6	73501102	1/4 NPT X 3/8 TUBE FLOW CONTROL	2
7	74203001	3/8 OD TUBE x 1/4 NPT MALE CONNECTOR, PLASTIC	4
8	74203501	3/8 OD TUBE, UNION TEE, PLASTIC	6
9	74204601	3/8 OD x 1/4 NPT STEM ADAPTER	3
10	75102201	E-ring retainer for 1/2 rod #5133-50H	8
11	75102301	E-RING RETAINER FOR 3/4 ROD	2
12	75104201	3/8-16 HEX NUT, S/S	8
13	75105101	1/2-20 HEX JAM NUT, S/S	4
14	75113401	1/4-28 X 1 LNG HEX HEAD CAP SCREW, S/S	8
15	75117201	1 3/8 - 12 UNF CYLINDER LICK NUT	4
16	75118101	1/4-28 HEX JAM NUT, S/S	2
17	76102401A	KEY, BEARING BLOCK/BUTTRESS	2
18	76102501A	PIN, SEAL BAR CLEVIS	4
19	76125301A	SHORT CLEVIS, HEAT SEAL BAR,MACHINED HEAD ESIGN	4
20	79101201	FLANGED BEARING SLEEVE, 1/2ID 19/32 OD 1/2 LONG (LINK & V32)	4
21	86102401A	LINK, PIVOT SHAFT TO BACKUP BAR FOR FLANGED SLEEVES	2
22	74400601	1/4 CLOSE NIPPLE S/S	2
23	74400701	1/4 NPT 90 Deg. STREET ELBOW S/S	3
24	74400501	1/4 NPT FEMALE TEE S/S	2
25	74204201	3/8 O.D. TUBE X 1/4 NPT FIXED ELBOW, MALE, PLASTIC	1
26	75108501	3/8-16 X 2 1/4 THREADED ROD S/S	4
27	79002201	WARNING MOVING PARTS LABEL	2
28	79002101	WARNING AVOID BURNS LABEL	2
29	79000801	TUBE HOLDER PLASTIC 7 POS 3/8	1

REVISIONS			
REV	DESCRIPTION	DATE	APPROVED
A	INITIAL RELEASE TO PRODUCTION	2/4/2020	MTEKCOR P\bbange
B	REPLACED BRASS FITTINGS WITH STAINLESS, ADDED STICKERS	11/26/24	RB

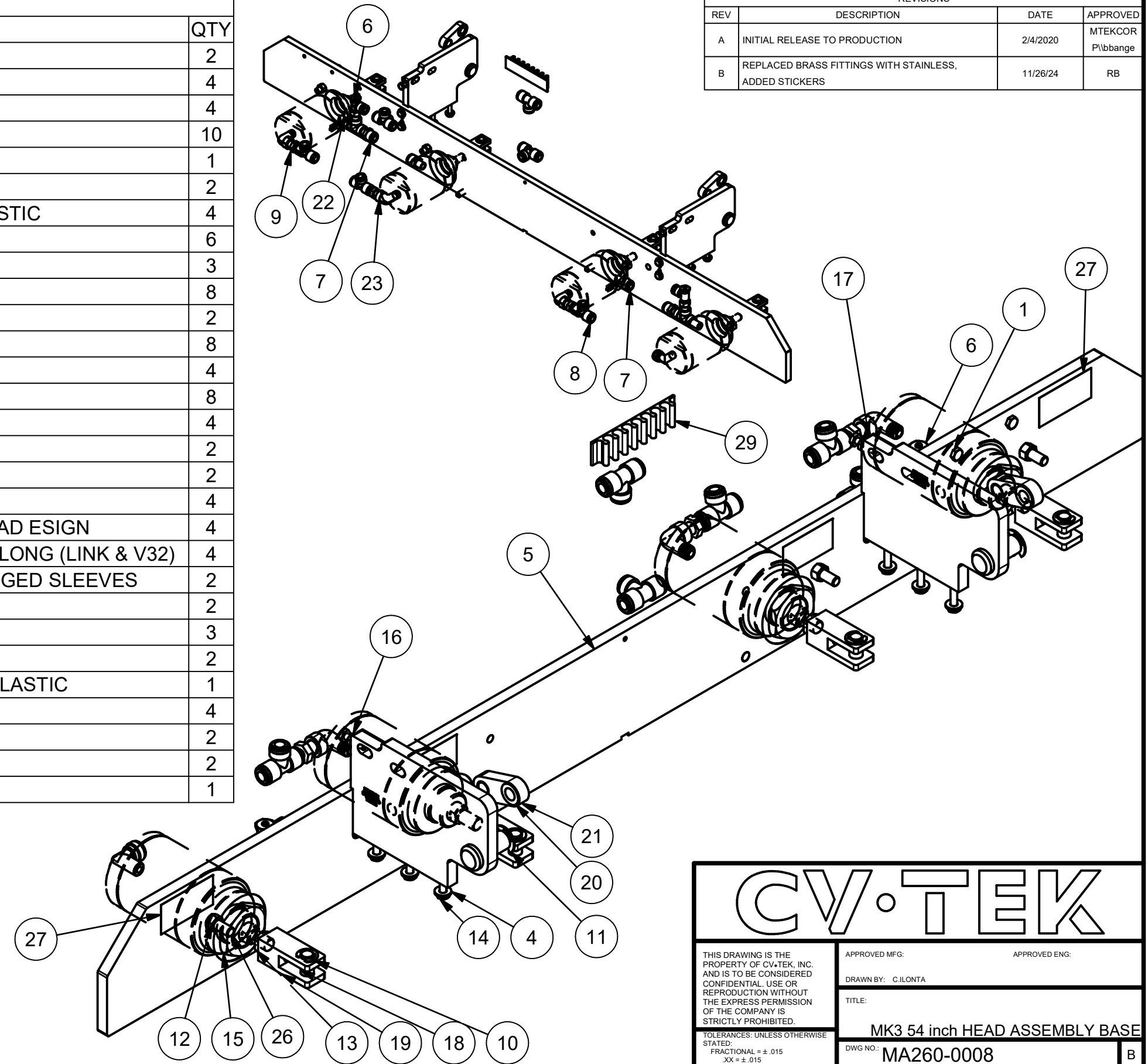

# CV•TEK

THIS DRAWING IS THE PROPERTY OF CV•TEK, INC. AND IS TO BE CONSIDERED CONFIDENTIAL. USE OR REPRODUCTION WITHOUT THE EXPRESS PERMISSION OF THE COMPANY IS STRICTLY PROHIBITED.

TOLERANCES: UNLESS OTHERWISE STATED:  
 FRACTIONAL = ± .015  
 XX = ± .015  
 .XXX = ± .005  
 .XXXX = ± .0005  
 DRILLED HOLE - STANDARD S.A.E.

APPROVED MFG:	APPROVED ENG:
DRAWN BY: C.ILONTA	TITLE:
MK3 54 inch HEAD ASSEMBLY BASE	
DWG NO.: MA260-0008	B
SCALE: N/A	DATE:
SHEET 1 OF 1	

PARTS LIST			
ITEM	PART NO.	DESCRIPTION	QTY
1	108586C1	1/4-20 X 5/8 LNG HEX HEAD CAP SCREW, S/S	2
2	110544C1	1/4 FLAT WASHER, 0.630 O.D., 0.08 THCK, S/S	6
3	130276C1	MAP VAC FRAME PLATE 62 COMPLETE	1
4	73501102	1/4 NPT X 3/8 TUBE FLOW CONTROL	2
5	74203001	3/8 OD TUBE x 1/4 NPT MALE CONNECTOR, PLASTIC	4
6	74203501	3/8 OD TUBE, UNION TEE, PLASTIC	4
7	74204201	3/8 O.D. TUBE X 1/4 NPT FIXED ELBOW, MALE, PLASTIC	1
8	74204601	3/8 OD x 1/4 NPT STEM ADAPTER	3
9	74400501	1/4 NPT FEMALE TEE S/S	2
10	74400601	1/4 CLOSE NIPPLE S/S	2
11	74400701	1/4 NPT 90 Deg. STREET ELBOW S/S	3
12	75102201	E-ring retainer for 1/2 rod #5133-50H	8
13	75102301	E-RING RETAINER FOR 3/4 ROD	2
14	75104201	3/8-16 HEX NUT, S/S	8
15	75105101	1/2-20 HEX JAM NUT, S/S	4
16	75113401	1/4-28 X 1 LNG HEX HEAD CAP SCREW, S/S	8
17	75116501	3/8-16 X 2 1/2 THREADED RODE S/S	4
18	75117201	1 3/8 - 12 UNF CYLINDER LICK NUT	4
19	75118101	1/4-28 HEX JAM NUT, S/S	2
20	76102401A	KEY, BEARING BLOCK/BUTTRESS	2
21	76102501A	PIN, SEAL BAR CLEVIS	4
22	76125301A	SHORT CLEVIS, HEAT SEAL BAR,MACHINED HEAD ESIGN	4
23	79101201	FLANGED BEARING SLEEVE, 1/2ID 19/32 OD 1/2 LONG (LINK & V32)	4
24	86102401A	LINK, PIVOT SHAFT TO BACKUP BAR FOR FLANGED SLEEVES	2

REVISIONS			
REV	DESCRIPTION	DATE	APPROVED
A	INITIAL RELEASE	11/01/2018	CI
B	CYLINDERS SHOWN AS REFERENCE, 74204601 QTY 3, 74400601 QTY 2, 74203501 QTY 4	11/5/2024	SP

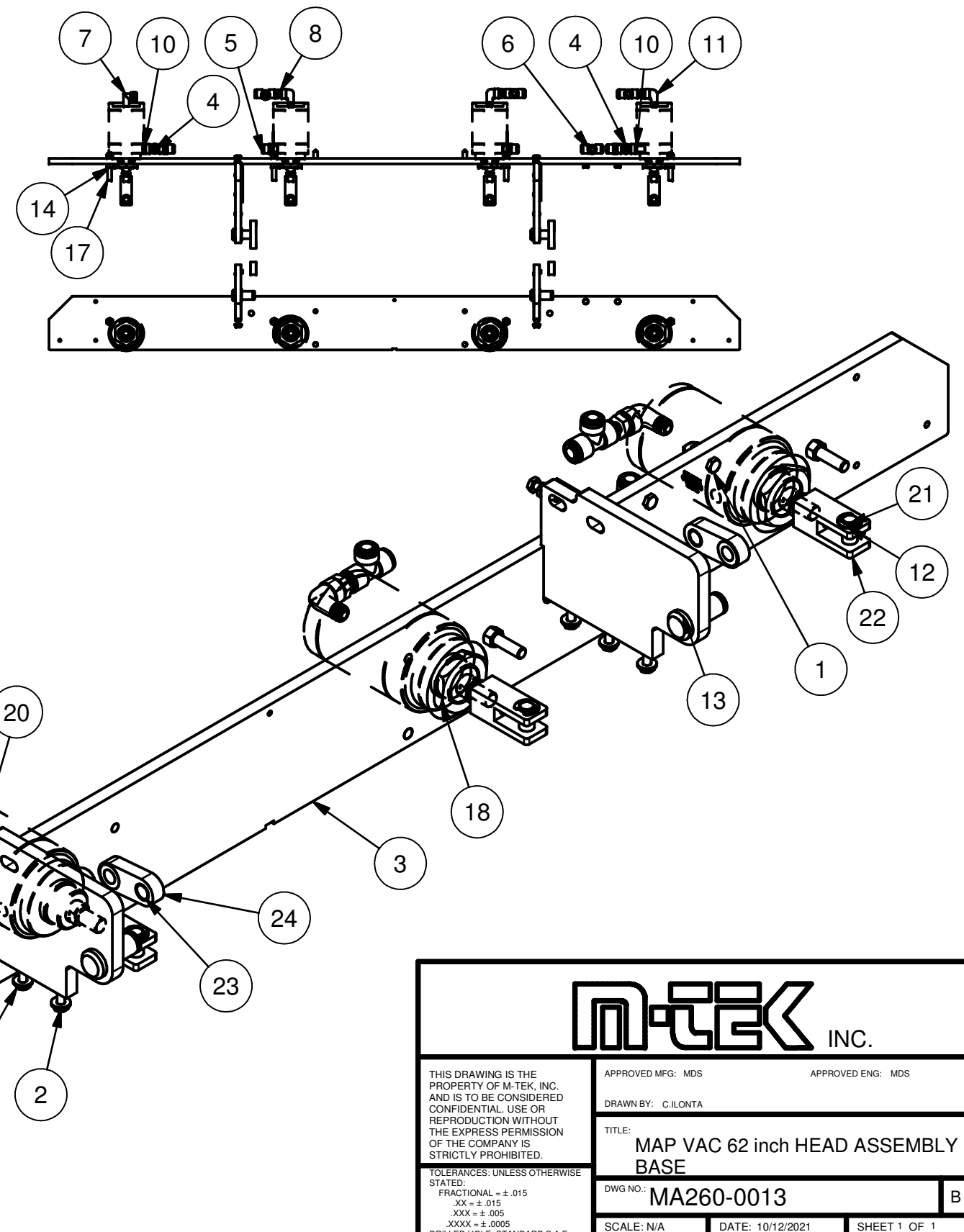

<b>M-TEK</b> INC.	
THIS DRAWING IS THE PROPERTY OF M-TEK, INC. AND IS TO BE CONSIDERED CONFIDENTIAL. USE OR REPRODUCTION WITHOUT THE EXPRESS PERMISSION OF THE COMPANY IS STRICTLY PROHIBITED.	APPROVED MFG: MDS APPROVED ENG: MDS
TOLERANCES: UNLESS OTHERWISE STATED: FRACTIONAL = ± .015 XX = ± .015 XXX = ± .005 XXXX = ± .0005 DRILLED HOLE: STANDARD S.A.F.	DRAWN BY: C.ILONTA
	TITLE: MAP VAC 62 inch HEAD ASSEMBLY BASE
	DWG NO.: MA260-0013
SCALE: N/A	DATE: 10/12/2021
	SHEET 1 OF 1

NOTE: AIR CYLINDERS SHOWN AS REFERENCE

PARTS LIST			
ITEM	PART NO.	DESCRIPTION	QTY
1	129983C1	MAP VAC 54" LOWER PAN WELDMENT	1
2	130001C2	MAPVAC PINCH PLATE REWORK 61-1/2, 15 PROBE	1
3	75100501A	BOLT, SEAL BAR GUARD 1/4-28 UNF X 2 1/4 STAINLESS STEEL	2
4	75106201	#10-32 X 3/4 LNG HEX HEAD MACHINE SCREW, S/S	4
5	75110701	#10-32 X 1/2 LNG HEX HEAD MACHINE SCREW, S/S	6
6	76102001A	CLAMP, REAR PROBE SEAL	2
7	76102201A	SPACER, SEAL BAR GUARD 1-11/16 LONG	2
8	79500202	BLACK RUBBER REAR PROBE SEAL	2
9	126054C1	RH PINCH COVER WELDMENT	1
10	126053C1	LH PINCH COVER WELDMENT	1
11	126285C1	7/16" X 3/4" EPDM FOAM	1

REVISIONS			
REV	DESCRIPTION	DATE	APPROVED
A	INITIAL RELEASE	10/13/2021	CI
B	UPDATED ITEM #3 TO MATCH INFOR	1/7/2025	GW
C	ADDED SIDE GUARDS	3/7/25	RB

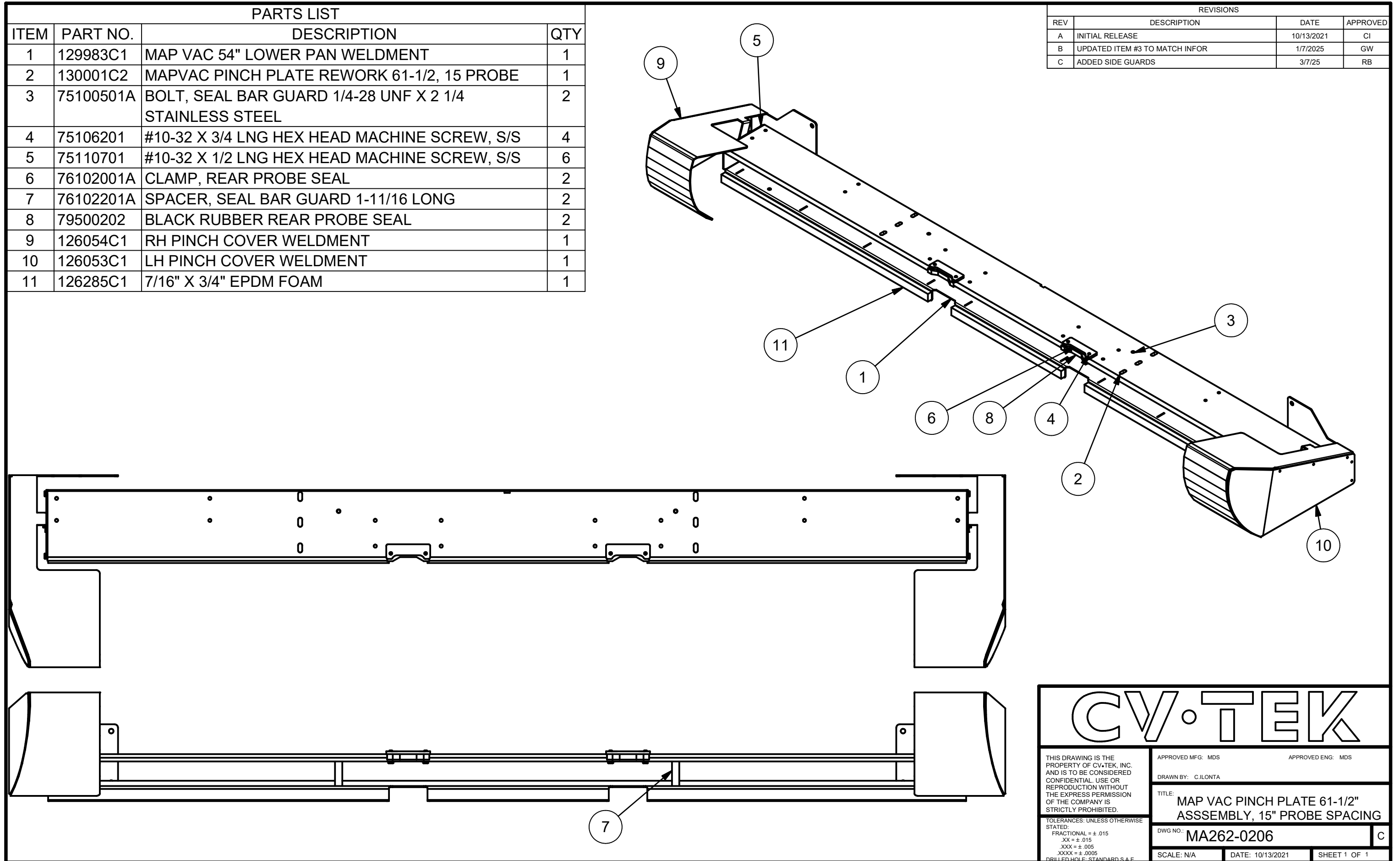

# CV•TEK

THIS DRAWING IS THE PROPERTY OF CV•TEK, INC. AND IS TO BE CONSIDERED CONFIDENTIAL. USE OR REPRODUCTION WITHOUT THE EXPRESS PERMISSION OF THE COMPANY IS STRICTLY PROHIBITED.

TOLERANCES: UNLESS OTHERWISE STATED:  
 FRACTIONAL = ± .015  
 XX = ± .015  
 XXX = ± .005  
 XXXX = ± .0005  
 DRILLED HOLE: STANDARD S.A.E.

APPROVED MFG: MDS	APPROVED ENG: MDS
DRAWN BY: C.ILONTA	
TITLE: MAP VAC PINCH PLATE 61-1/2" ASSEMBLY, 15" PROBE SPACING	
DWG NO.: MA262-0206	C
SCALE: N/A	DATE: 10/13/2021
SHEET 1 OF 1	

PARTS LIST			
ITEM	PART NO.	DESCRIPTION	QTY
1	75100501A	BOLT, SEAL BAR GUARD 1/4-28 UNF X 2 1/4 STAINLESS STEEL	2
2	75106201	#10-32 X 3/4 LNG HEX HEAD MACHINE SCREW, S/S	4
3	75110701	#10-32 X 1/2 LNG HEX HEAD MACHINE SCREW, S/S	6
4	76102001A	CLAMP, REAR PROBE SEAL	2
5	76102201A	SPACER, SEAL BAR GUARD 1-11/16 LONG	2
6	76112502	PINCH PLATE 61-1/2, 9-1/4 PROBE	1
7	79500202	BLACK RUBBER REAR PROBE SEAL	2
8	131102C1	MAP VAC 62, 9.25" SPACE LOWER PAN WELDMENT	1
9	126054C1	RH PINCH COVER WELDMENT	1
10	126053C1	LH PINCH COVER WELDMENT	1
11	126285C1	7/16" X 3/4" EPDM FOAM	1

REVISIONS			
REV	DESCRIPTION	DATE	APPROVED
A	INITIAL RELEASE	9/19/2018	N.B
B	ADDED SIDE GAURDS	3/7/25	RB

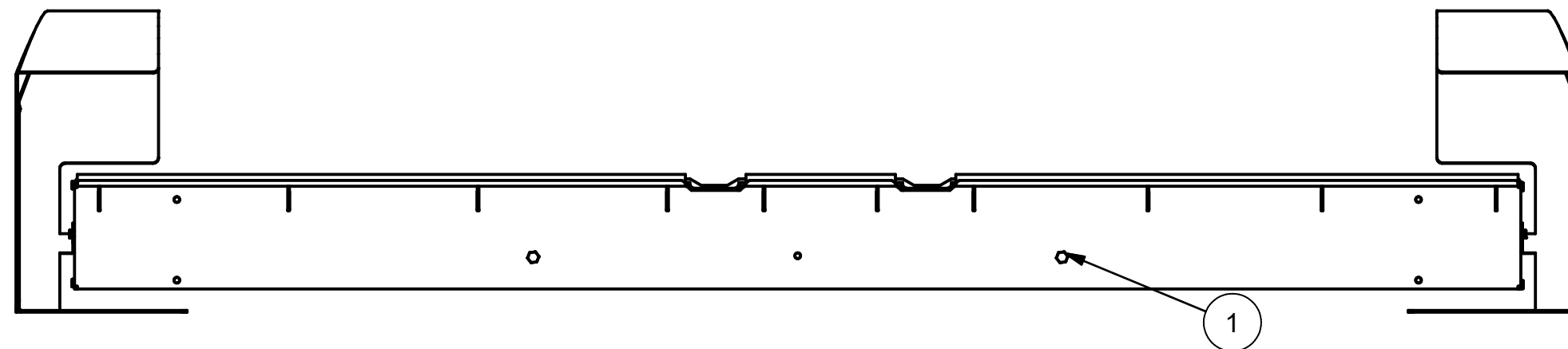
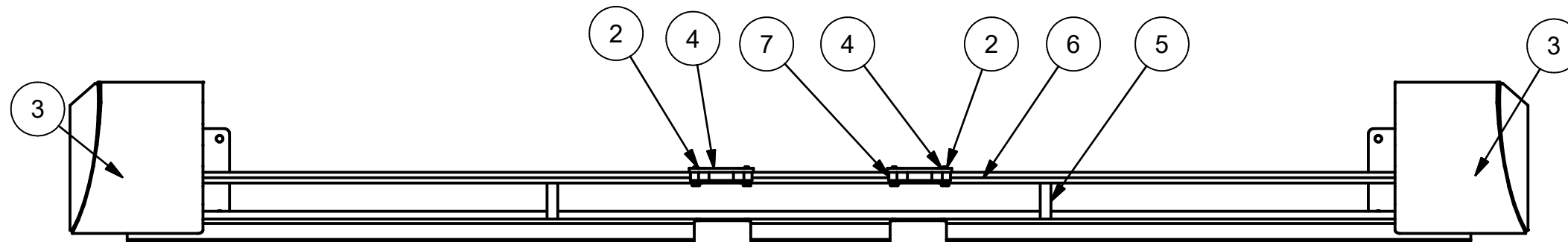
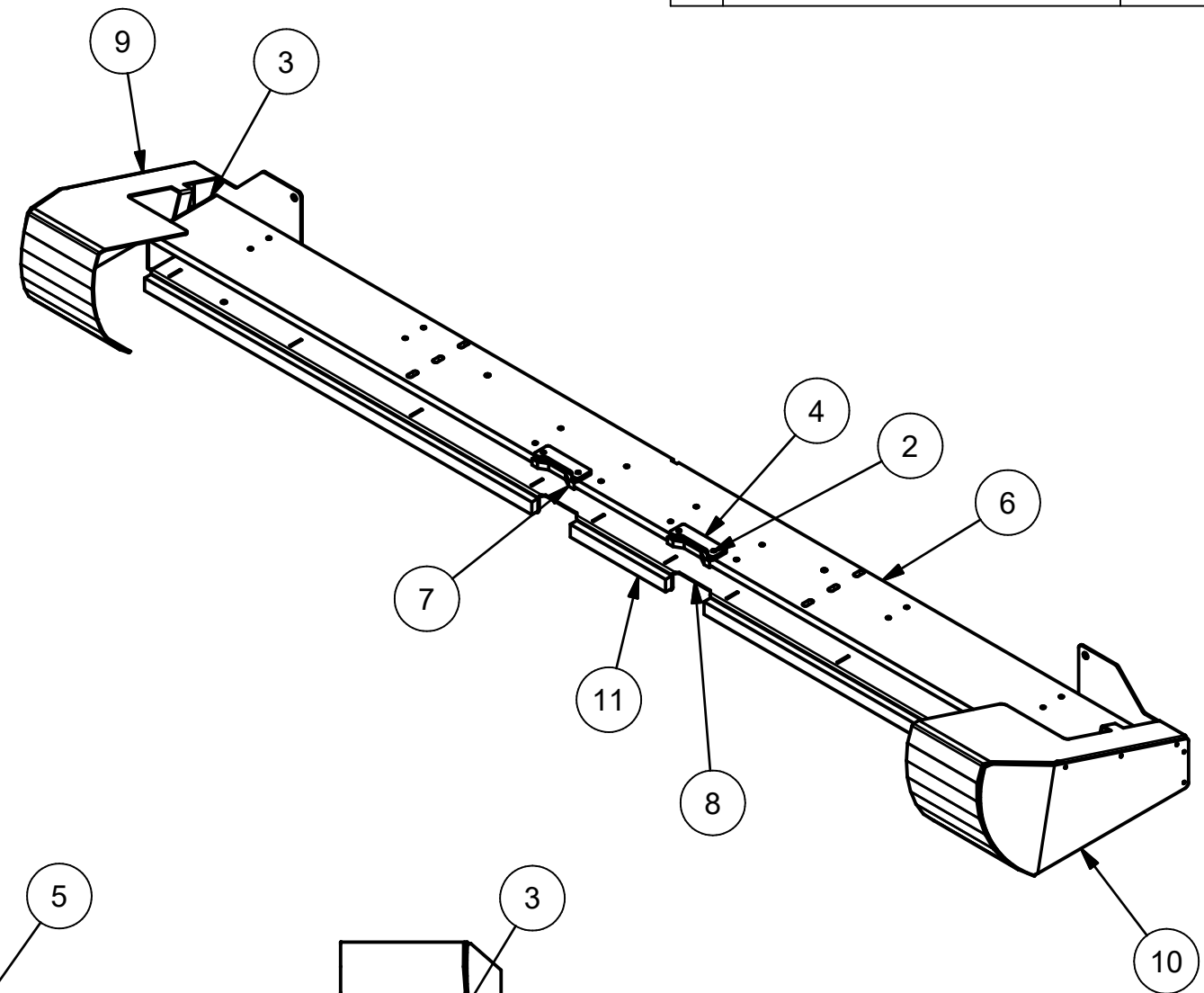

CV•TEK

THIS DRAWING IS THE PROPERTY OF CV•TEK, INC. AND IS TO BE CONSIDERED CONFIDENTIAL. USE OR REPRODUCTION WITHOUT THE EXPRESS PERMISSION OF THE COMPANY IS STRICTLY PROHIBITED.	APPROVED MFG: _____ APPROVED ENG: _____
DRAWN BY: C.ILONTA	TITLE: MK3 PINCH PLATE 61-1/2" ASSEMBLY, 9-1/4" PROBE SPACING
DWG NO.: MA262-0207	B
SCALE: N/A	DATE: _____ SHEET 1 OF 1

TOLERANCES: UNLESS OTHERWISE STATED:  
 FRACTIONAL = ± .015  
 XX = ± .015  
 .XXX = ± .005  
 .XXXX = ± .0005  
 DRILLED HOLE: STANDARD S.A.E.

REVISIONS			
REV	DESCRIPTION	DATE	APPROVED
A	INITIAL RELEASE	10/23/2018	CI
B	ADD FUSE #24	2/26/2025	CI

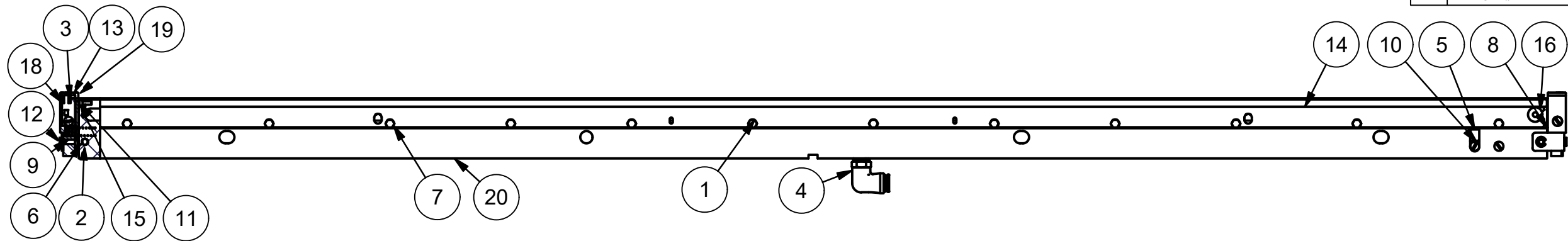

PARTS LIST

ITEM	PART NO.	DESCRIPTION	QTY
1	.190-32 x .375lg (75106101)	10-32 X 3/8 Hhcs TRIMMED S/S	12
2	76111401	PIN IMPULSE TERMINAL PIVOT	2
3	71201301	HIGH ENERGY IMPULSE BAND 60.5 INCH LONG; 3/16 INCH WIDE	1
4	74103001	1/2 X 3/8 Parker Male Elbow	1
5	75000901	3/8 DIA. TUBE CLAMP x 3/8 WIDE	1
6	75102101	E-RING RETAINER FOR 1/4 ROD	4
7	75102501	#10 MED SPLIT LOCK WASHERS, S/S	12
8	75105501	SPRING; IMPULSE TERMINAL	2
9	75109801H	#10-32 X 5/8 PAN HEAD, SLOTTED, S/S	6
10	75112101	#10-32 X 3/8 PAN HEAD, SLOTTED, S/S	2
11	75112201	#6-32 X 3/8 SOCKET HEAD CAP SCREW, S/S	2
12	76111501	IMPULSE TERMINAL BRACKET WITH 10-32 PEM NUT	2
13	76124201	BAND RETAINER, IMPULSE SERIES B 1/8 TO 3/16 INCH HE BAND WIDTH	2
14	76124401	COVER, 60-1/2" IMPULSE COOLING CHANNEL	1
15	79100401	INSULATOR BLOCK FOR IMPULSE BAR ENDS	2
16	79500601	PLUG GROMMET 3/16 I.D., 5/8 O.D., 5/16 PANEL HOLE	2
17	86103501	SPACER, IMPULSE TERMINAL BLOCK	2
18	86103601A	TERMINAL LUG; IMPULSE 1/8 TO 3/16 INCH BAND WIDTH	2
19	89100901	TERMINAL BLOCK; IMPULSE 1/8 TO 3/16 INCH BAND WIDTH	2
20	89101001	SEAL BAR 60-1/2 INCH ALUMINUM IMPULSE	1
21	71106501	CURRENT TRANSFORMER; 10-100A AC; .4 - 4V PEAK TO PEAK OUTPUT #MI100	1
22	71104502	Relay, solid state 24-265VAC	1
23	71003301	CIRCUIT BOARD; IMPULSE CONTROL MODULE	1
24*	71401601	Fuse 32 amp type aM	1

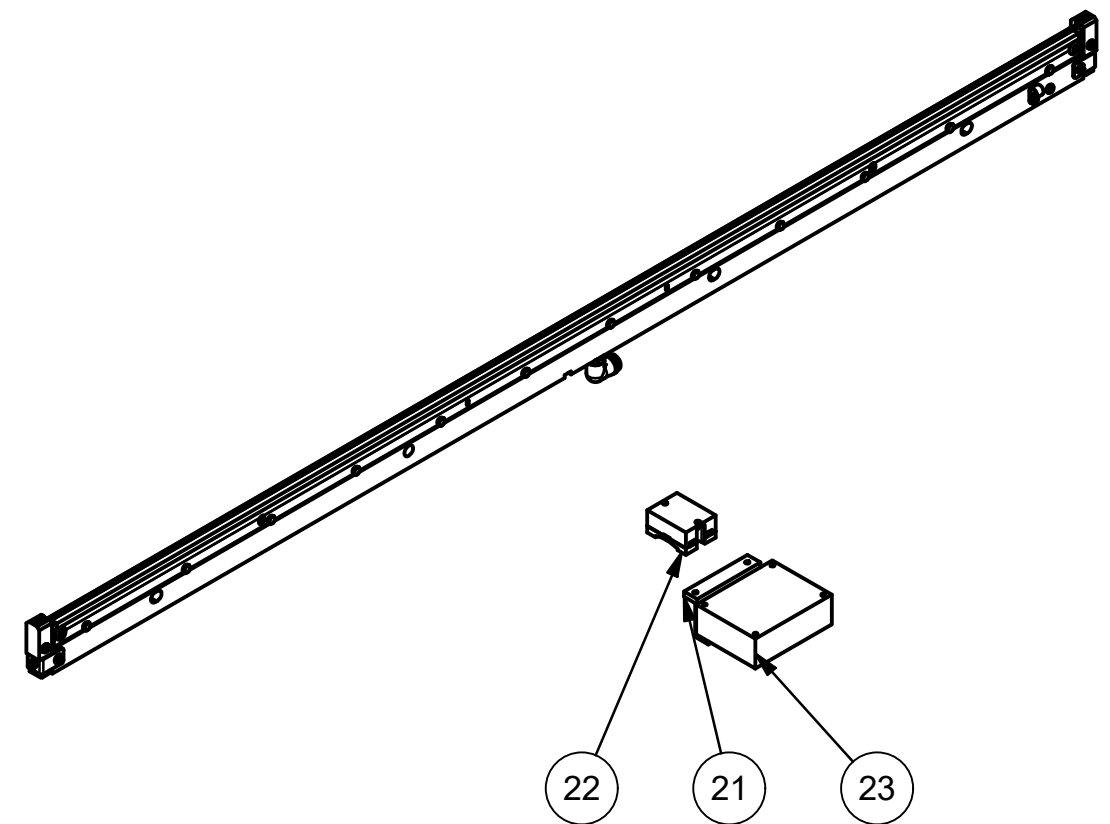

# CV•TEK

THIS DRAWING IS THE PROPERTY OF CV•TEK, INC. AND IS TO BE CONSIDERED CONFIDENTIAL. USE OR REPRODUCTION WITHOUT THE EXPRESS PERMISSION OF THE COMPANY IS STRICTLY PROHIBITED. TOLERANCES: UNLESS OTHERWISE STATED: FRACTIONAL = ± .015 .XX = ± .015 .XXX = ± .005 .XXXX = ± .0005 DRILLED HOLE: STANDARD S.A.F.	APPROVED MFG: _____ APPROVED ENG: _____ DRAWN BY: C.LLONTA TITLE: <b>MK3 60-1/2" IMPULSE HIGH ENERGY SEAL BAR ASSEMBLY</b> DWG NO: <b>MA263-0023</b>
SCALE: N/A      DATE: _____	SHEET 1 OF 1

\*-PARTS NOT PICTURED

REVISIONS			
REV	DESCRIPTION	DATE	APPROVED
A	INITIAL RELEASE		N.B
B	ADDED RTD CABLE	4/5/2024	JRS

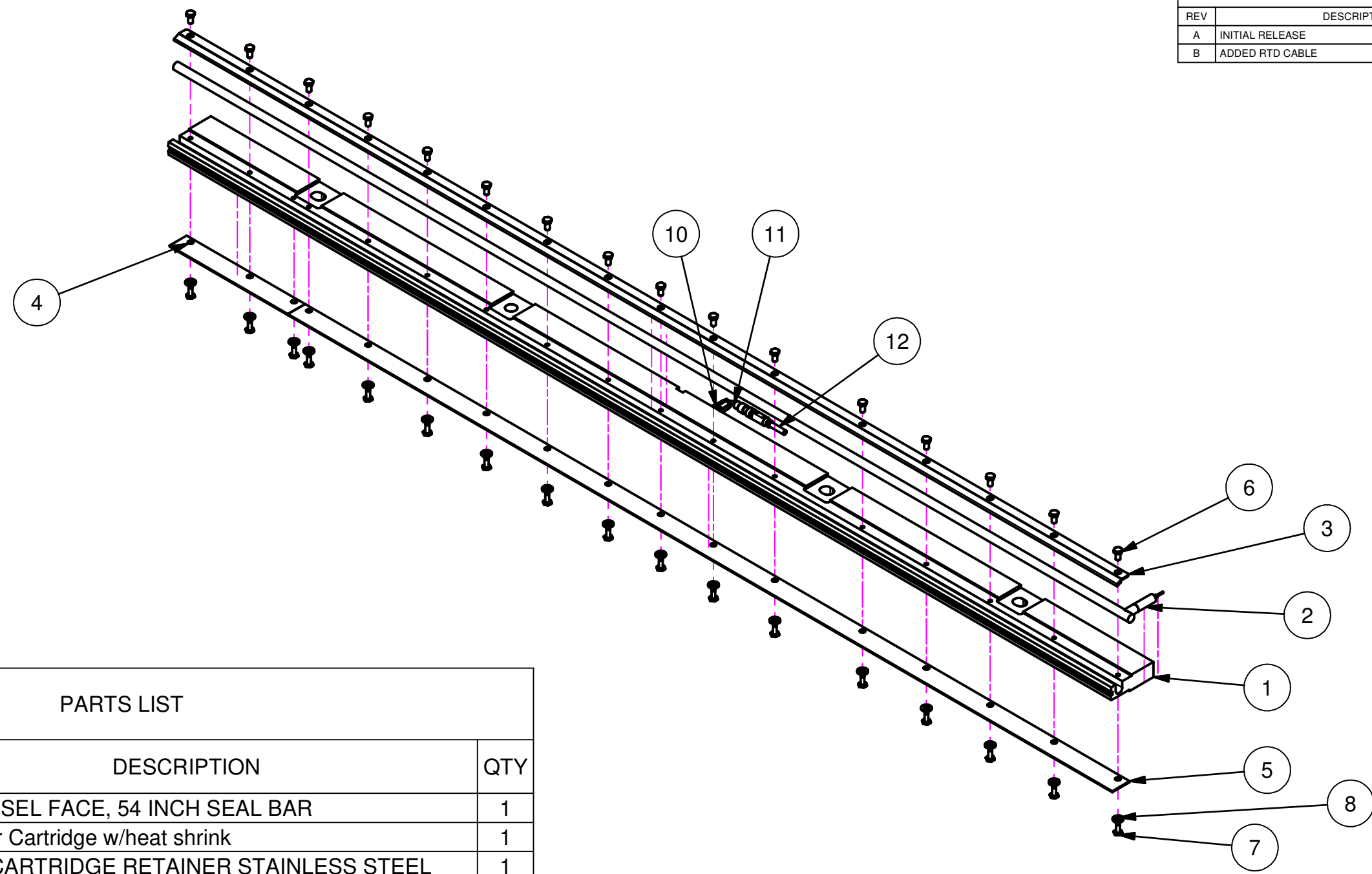

PARTS LIST

ITEM	PART NO.	DESCRIPTION	QTY
1	125705C1	DUAL CHISEL FACE, 54 INCH SEAL BAR	1
2	71200102	54" Heater Cartridge w/heat shrink	1
3	76125801	54 INCH CARTRIDGE RETAINER STAINLESS STEEL FOR CHISEL FACE, COOL EDGE SEAL BAR	1
4	79102301	RIGHT HAND 54" CHISEL FACE COOL EDGE	1
5	79102302	LEFT HAND 54" CHISEL FACE COOL EDGE	1
6	110221C1	10-24 UNC X 3/8 LG. - HHMS	16
7	75106101	10-32 X 3/8 Hhcs TRIMMED S/S	17
8	75102801	#10 FLAT WASHER (.208 I.D. x .434 O.D. x .05 THK.)	17
9	121838C1	CABLE 5M, PICO, 3 PIN, SHIELDED	1
10	120297C1	COUPLING 1/8"	1
11	125842C1	CUSTOM RTD 3" LONG BENT 90 DEG ; M8 CONNECTOR	1
12	121838C1	M8 FEMALE CONNECTOR STRAIGHT W/5M	1

\*\*NOT SHOWN

## CV•TEK

THIS DRAWING IS THE PROPERTY OF CV•TEK, INC. AND IS TO BE CONSIDERED CONFIDENTIAL. USE OR REPRODUCTION WITHOUT THE EXPRESS PERMISSION OF THE COMPANY IS STRICTLY PROHIBITED.

TOLERANCES: UNLESS OTHERWISE STATED:  
 FRACTIONAL = ± .015  
 XX = ± .015  
 .XXX = ± .005  
 .XXXX = ± .0005  
 DRILLED HOLE: STANDARD S.A.E.

APPROVED MFG:	APPROVED ENG:
DRAWN BY: rowdy	
TITLE: MAPVAC 54" DUAL FACE SEAL BAR ASSEMBLY	
DWG NO.: MA263-0024	B
SCALE: N/A	DATE:
SHEET 1 OF 1	

REVISIONS			
REV	DESCRIPTION	DATE	APPROVED
A	INITIAL RELEASE		N.B
B	ADDED 125842C1, 120297C1, 121838C1	11/22/2024	VK

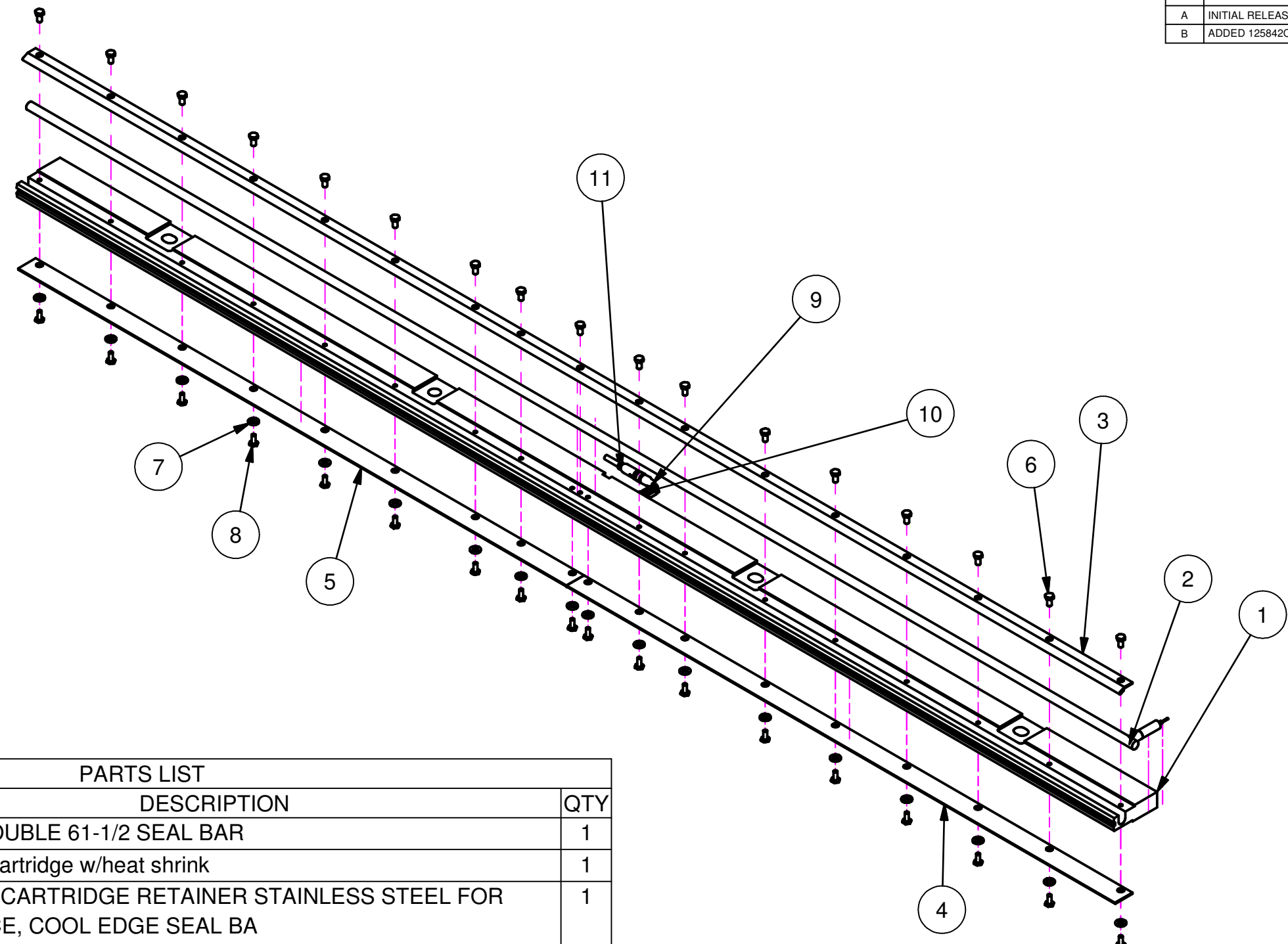

PARTS LIST

ITEM	PART NO.	DESCRIPTION	QTY
1	130264C1	MAPVAC DOUBLE 61-1/2 SEAL BAR	1
2	71200402	62" Heater Cartridge w/heat shrink	1
3	76125901A	61-1/2 INCH CARTRIDGE RETAINER STAINLESS STEEL FOR CHISEL FACE, COOL EDGE SEAL BA	1
4	79102402	RIGHT HAND 61-1/2 INCH CHISEL FACE COOL EDGE	1
5	79102401	LEFT HAND 61-1/2 INCH CHISEL FACE COOL EDGE	1
6	110221C1	10-24 UNC X 3/8 LG. - HHMS	17
7	75102801	#10 FLAT WASHER (.208 I.D. x .434 O.D. x .05 THK.)	18
8	75106101	10-32 X 3/8 Hhcs TRIMMED S/S	18
9	125842C1	CUSTOM RTD 3" LONG BENT 90 DEG ; M8 CONNECTOR	1
10	120297C1	COUPLING 1/8"	1
11	121838C1	M8 FEMALE CONNECTOR STRAIGHT W/5M	1

# CV•TEK

THIS DRAWING IS THE PROPERTY OF CV•TEK, INC. AND IS TO BE CONSIDERED CONFIDENTIAL. USE OR REPRODUCTION WITHOUT THE EXPRESS PERMISSION OF THE COMPANY IS STRICTLY PROHIBITED.

TOLERANCES: UNLESS OTHERWISE STATED:  
 FRACTIONAL = ± .015  
 XX = ± .015  
 .XXX = ± .005  
 .XXXX = ± .0005  
 DRILLED HOLE: STANDARD S.A.E.

APPROVED MFG:	APPROVED ENG:
DRAWN BY: rowdy	
TITLE: MAPVAC 62" DUAL FACE SEAL BAR ASSEMBLY	
DWG NO.: MA263-0025	B
SCALE: N/A	DATE:
SHEET 1 OF 1	

PARTS LIST			
ITEM	PART NO.	DESCRIPTION	QTY
1	79100101	BUSHING, BRONZE 3/4 ID X 7/8 OD	2

REVISIONS			
REV	DESCRIPTION	DATE	APPROVED
A	INITIAL RELEASE	11/01/2018	CI

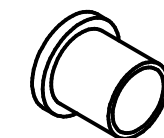
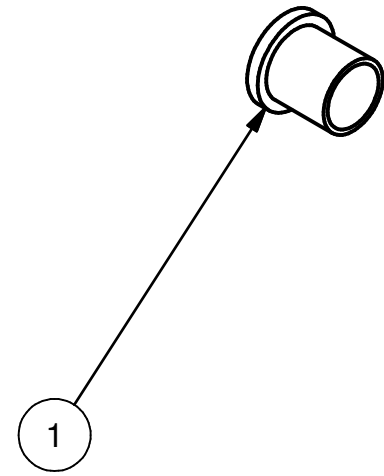

THIS DRAWING IS THE PROPERTY OF M-TEK, INC. AND IS TO BE CONSIDERED CONFIDENTIAL. USE OR REPRODUCTION WITHOUT THE EXPRESS PERMISSION OF THE COMPANY IS STRICTLY PROHIBITED.  TOLERANCES: UNLESS OTHERWISE STATED: FRACTIONAL = ± .015 .XX = ± .015 .XXX = ± .005 .XXXX = ± .0005 DRILLED HOLE: STANDARD S.A.E.	APPROVED MFG:	APPROVED ENG:
	DRAWN BY: C.I.LONTA	
	TITLE: BACKUP BAR BRONZE BUSHING SET	
	DWG NO.: MA264-0025	A
SCALE: N/A	DATE:	SHEET 1 OF 1

PARTS LIST			
ITEM	PART NO.	DESCRIPTION	QTY
1	120586C1	M12 4PIN 90DEG 2M BLACK FEMALE CABLE	1
2	126048C1	M12 SAFETY PROX	1
3	128566C1	M19733; 1-3/4" bore, Stainless Custom cylinder	1
4	73501102	1/4 NPT X 3/8 TUBE FLOW CONTROL	2
5	75101901	1/4-20 UNC X 3/8 LG. SOCKET SETSCREW, CUP POINT	1
6	75103401	3/8 FLAT WASHER (.406 I.D. X .875 O.D. X .047 THK.)	10
7	75103901	1/4-28 HEX NUT, S/S	2
8	75104601	Ø5/16 X 5/16 SOCKET HEAD SHOULDER SCREW, S/S	2
9	75107001	1/4-28 X 1-1/4 LNG HEX HEAD CAP SCREW, S/S, (FULL THD)	2
10	75107701	5/16-18 X 1 LNG HEX HEAD CAP SCREW, S/S	2
11	75108101	3/8-16 X 1-1/2 LNG HEX HEAD CAP SCREW, S/S	6
12	75108201	3/8-16 X 1-1/2 LNG SPECIAL 7/8 SHANK HEX HEAD CAP SCREW, S/S	4
13	75111401	7/16-20 HEX JAM NUT, S/S	1
14	75111501	FIN SEAL BAR SHOULDER BOLT	1
15	76103102A	STOP, PIVOT SHAFT	1
16	76103801A	BEARING BLOCK, LH/RH PIVOT SHAFT	1
17	76104601A	PIVOT SHAFT RIGHT HAND 54 / 61-1/2	1
18	76118501A	CLEVIS, JAW CLOSER CYLINDER	1
19	76118601A	TRUNNION BLOCK, JAW CLOSER CYLINDER	1
20	76118701A	TRUNNION BRACKET, JAW CLOSER CYLINDER	1
21	76118801A	TIE BAR, PIVOT SHAFT, USED W/JAW CLOSER	1
22	76118901A	PIVOT SHAFT LH 54/61-1/2 W/JAW CLOSER	1
23	76119001A	BEARING BLOCK, LH PIVOT SHAFT W/JAW CLOSER	1
24	76119301A	SPACER, TRUNNION BRACKET, JAW CLOSER CYLINDER	1
25	79101001	BEARING SLEEVE, JAW CLOSER CYLINDER CLEVIS	1

REVISIONS			
REV	DESCRIPTION	DATE	APPROVED
A	INITIAL RELEASE	2/12/2016	N.B
B	REPLACED AIR CYLINDER 73200602 WITH 128566C1	1/19/2021	ME

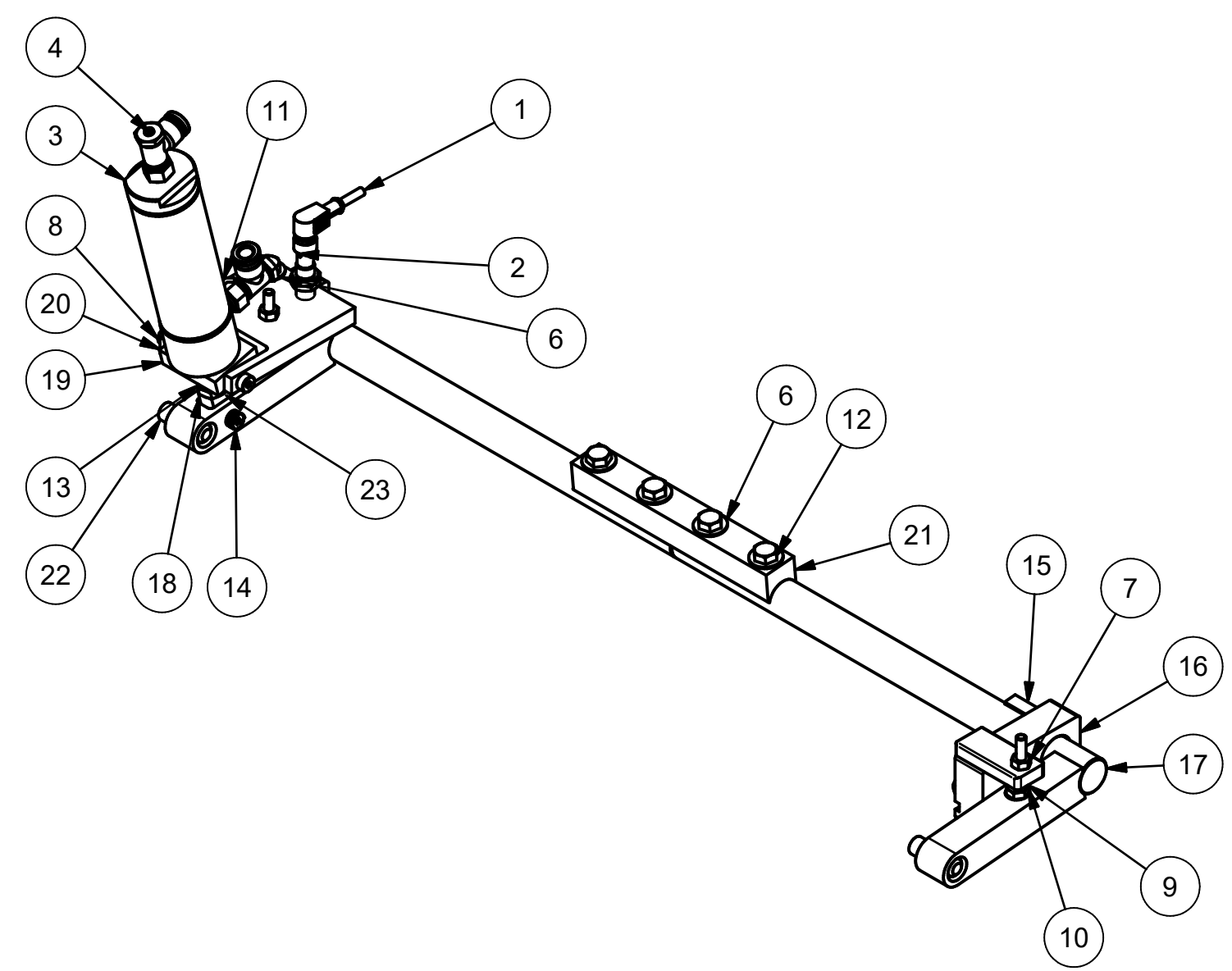

CV•TEK

THIS DRAWING IS THE PROPERTY OF CV•TEK, INC. AND IS TO BE CONSIDERED CONFIDENTIAL. USE OR REPRODUCTION WITHOUT THE EXPRESS PERMISSION OF THE COMPANY IS STRICTLY PROHIBITED.	APPROVED MFG: _____ APPROVED ENG: C. ILONTA DRAWN BY: C. ILONTA
TOLERANCES: UNLESS OTHERWISE STATED: FRACTIONAL = ± .015 XX = ± .015 XXX = ± .005 XXXX = ± .0005 DRILLED HOLE: STANDARD S.A.E.	TITLE: <b>MK3 54" AUTO BACKUP CLOSE ASSEMBLY</b> DWG NO.: <b>MA265-0013</b>
SCALE: N/A	DATE: 2/23/2016 SHEET 1 OF 1

PARTS LIST

ITEM	PART NO.	DESCRIPTION	QTY
1	73200102	CUST. LG BORE CYL w/SPEC. ROD GUIDE FOR 50 SER. (SEAL BAR)	4

REVISIONS			
REV	DESCRIPTION	DATE	APPROVED
A	INITIAL RELEASE	11/01/2018	CI

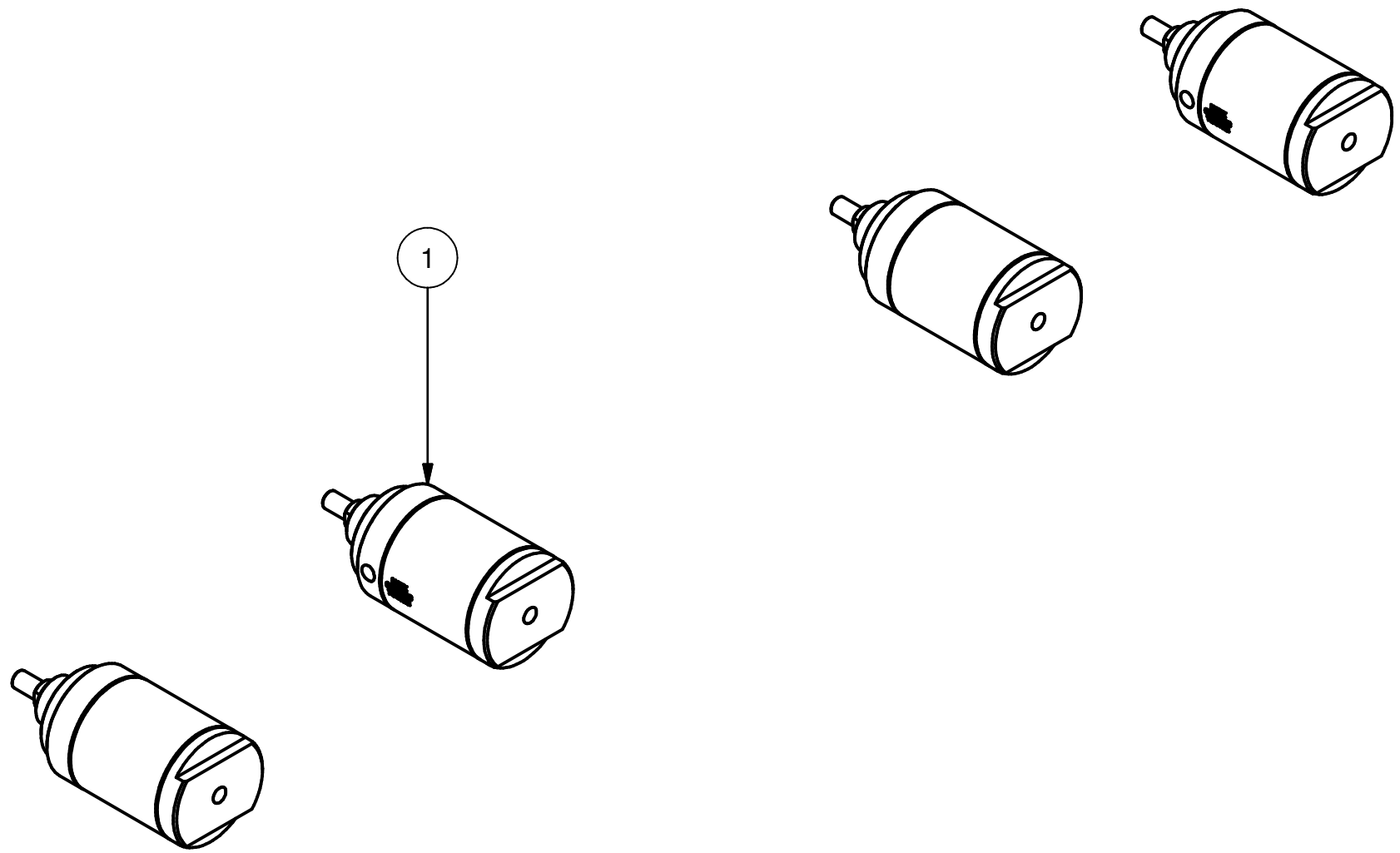

# CV•TEK

<p>THIS DRAWING IS THE PROPERTY OF CV•TEK, INC. AND IS TO BE CONSIDERED CONFIDENTIAL. USE OR REPRODUCTION WITHOUT THE EXPRESS PERMISSION OF THE COMPANY IS STRICTLY PROHIBITED.</p> <p>TOLERANCES: UNLESS OTHERWISE STATED:                  FRACTIONAL = ± .015                  XX = ± .015                  .XXX = ± .005                  .XXXX = ± .0005                  DRILLED HOLE: STANDARD S.A.E.</p>	APPROVED MFG:	APPROVED ENG:
	DRAWN BY: C.I.LONTA	
	TITLE: MK3 54/62 SEAL BAR LARGE BORE CYLINDERS 4X	
	DWG NO.: MA266-0011	A
SCALE: N/A	DATE:	SHEET 1 OF 1

PARTS LIST			
ITEM	PART NO.	DESCRIPTION	QTY
1	73200502	CYLINDER, COMPACT PROBE TOWER w/DELTRIN ENDS	1
2	75100601A	ROD COVER NUT, COMPACT PROBE TOWER	1
3	75100701	SPRING, PROBE EJECTOR, COMPACT PROBE TOWER, 3.25 LNG FOR 1/4 ROD	2
4	75102001	CIRCULAR PUSH-ON FOR 7/32 ROD	2
5	75102101	E-RING RETAINER FOR 1/4 ROD	6
6	75109601	1/4-20 X 7/8 LNG HEX HEAD CAP SCREW, S/S	2
7	75110101	1/4-28 X 1-3/4 LNG HEX HEAD CAP SCREW, S/S	4
8	75110701	#10-32 X 1/2 LNG HEX HEAD MACHINE SCREW, S/S	4
9	76105001A	PROBE PUSH BRACKET COMPLETE	1
10	76105101A	PROBE GUIDE, COMPACT PROBE	1
11	76105201A	BEARING PLATE, COMPACT PROBE TOWER	2
12	76105301A	GUIDE PIN, COMPACT PROBE TOWER	2
13	76105401A	CYLINDER ROD COVER, COMPACT	1
14	76105601A	PROBE CLEVIS, COMPACT PROBE TOWER	1
15	76105701A	CYLINDER MOUNTING PLATE, COMPACT PROBE TOWER	1
16	76105801A	SUPPORT BLOCK, COMPACT PROBE TOWER	2
17	76120601A	BRACKET, PROBE GUIDE COMPACT PROBE TOWER	1
18	123130C1	HALL EFFECT SWITCH ASSEMBLY	1
19	0651-1133	CABLE, 5m, 3 PIN	1
20	121846C1	SS SOURCING SWITCH (PNP)	1
21	73501102	1/4 NPT X 3/8 TUBE FLOW CONTROL	2
22	74400701	1/4 NPT 90 Deg. STREET ELBOW S/S	2
23	75100801	Cylinder mounting nut, compact 1-1/4-12 UNF S/S, 3/4 Thick	1
24	75105101	1/2-20 HEX JAM NUT S/S	1
25	75110201	1/4 FLAT WASHER (.265 I.D. X .500 O.D. X .032 THK.)	2

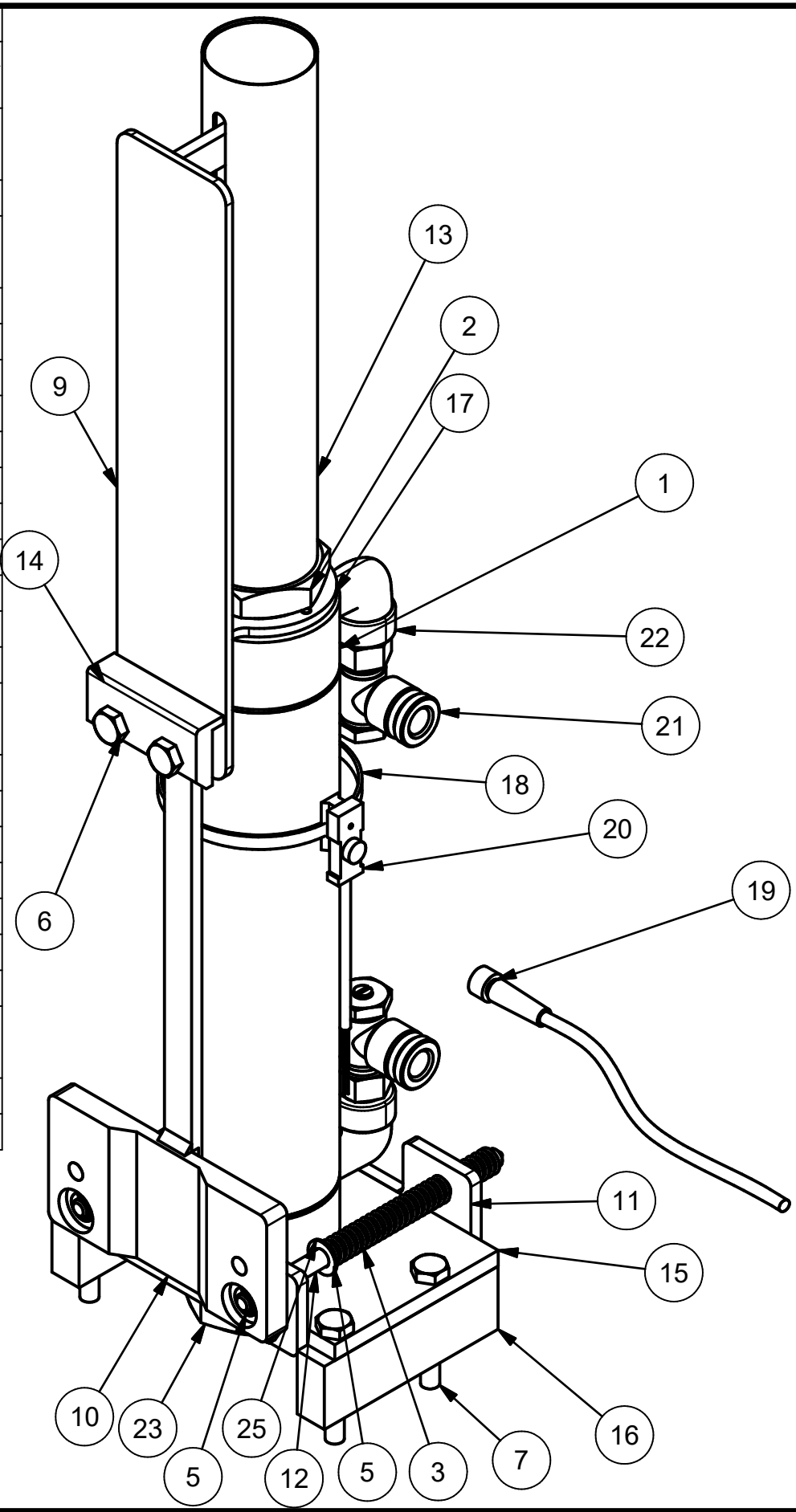

REVISIONS			
REV	DESCRIPTION	DATE	APPROVED
A	INITIAL RELEASE		N.B
B	ADDED ITEMS 22-26 TO MATCH INFOR	1/7/2025	GW

# CV•TEK

THIS DRAWING IS THE PROPERTY OF CV•TEK, INC. AND IS TO BE CONSIDERED CONFIDENTIAL. USE OR REPRODUCTION WITHOUT THE EXPRESS PERMISSION OF THE COMPANY IS STRICTLY PROHIBITED.

TOLERANCES: UNLESS OTHERWISE STATED:  
 FRACTIONAL = ± .015  
 XX = ± .015  
 .XXX = ± .005  
 .XXXX = ± .0005  
 DRILLED HOLE: STANDARD S.A.E.

APPROVED MFG:	APPROVED ENG:
DRAWN BY: admin	
TITLE: <b>BAREBONE COMPACT PROBE TOWER</b>	
DWG NO.: <b>MA270-0007</b>	<b>B</b>
SCALE: N/A	DATE: 8/10/2017
SHEET 1 OF 1	

PARTS LIST			
ITEM	PART NO.	DESCRIPTION	QTY
1	74200701	1/2 OD TUBE UNION	1
2	75100201	SPRING, PROBE COVER PLATE	2
3	75100401A	BOLT, PROBE COVER PLATE	2
4	75102101	E-RING RETAINER FOR 1/4 ROD	2
5	76101001	COVER PLATE, PROBE	1

REVISIONS			
REV	DESCRIPTION	DATE	APPROVED
A	INITIAL RELEASE	10/29/2018	CI

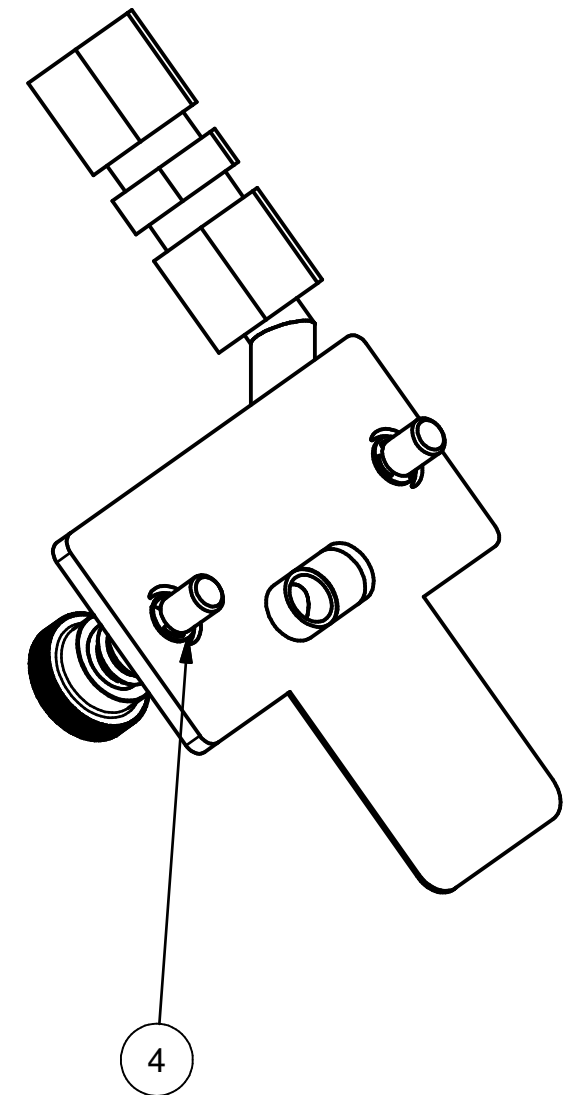
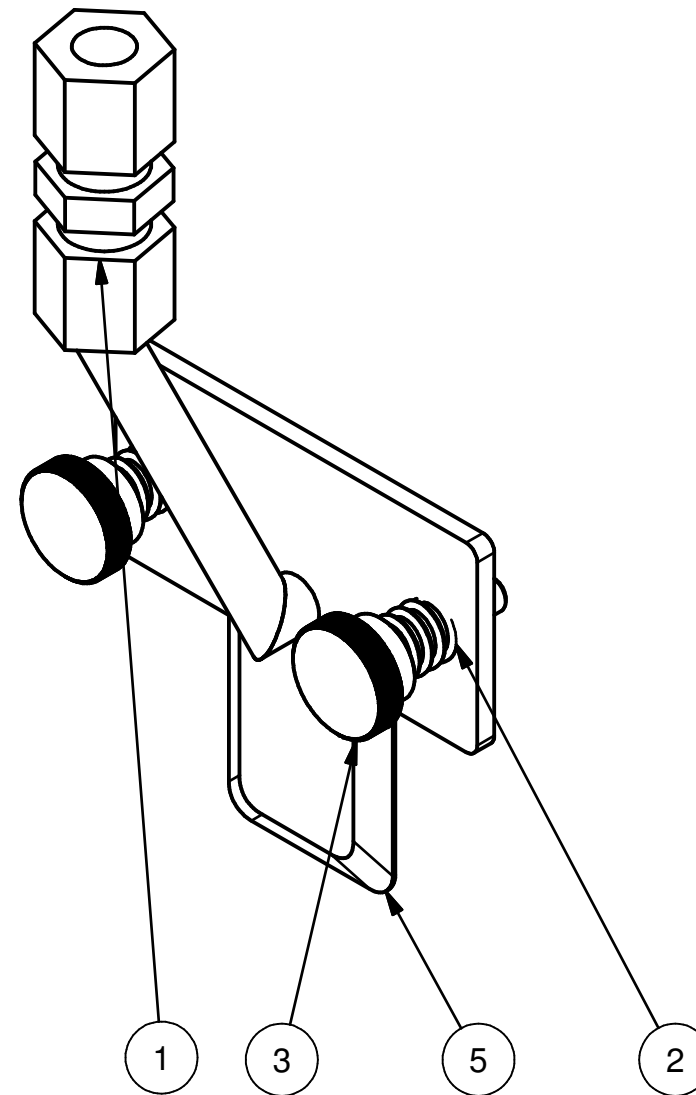
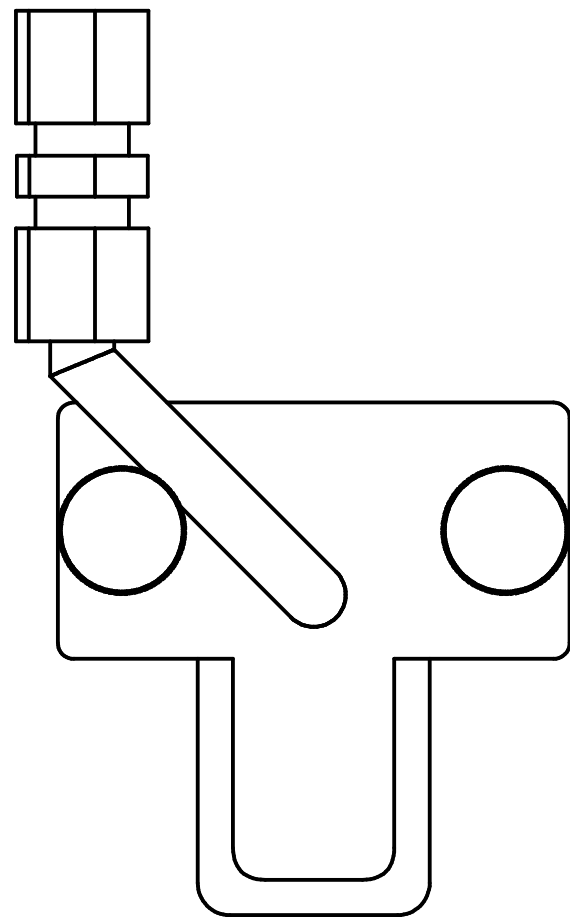
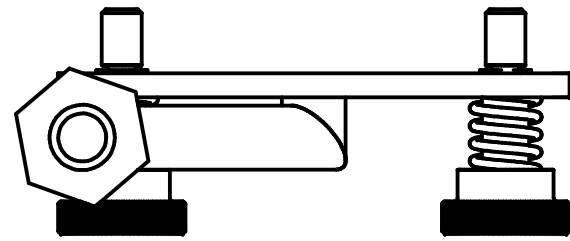

<h1>CV·TEK</h1>	
THIS DRAWING IS THE PROPERTY OF CV·TEK, INC. AND IS TO BE CONSIDERED CONFIDENTIAL. USE OR REPRODUCTION WITHOUT THE EXPRESS PERMISSION OF THE COMPANY IS STRICTLY PROHIBITED.  TOLERANCES: UNLESS OTHERWISE STATED: FRACTIONAL = ± .015 XX = ± .015 .XXX = ± .005 .XXXX = ± .0005 DRILLED HOLE: STANDARD S.A.E.	APPROVED MFG: _____ APPROVED ENG: C.ILONTA  DRAWN BY: CILONTA  TITLE: <h2 style="text-align: center;">COVER PLATE ASSEMBLY</h2>
	DWG NO.: <b>MA271-0002</b>
	SCALE: N/A      DATE: _____      SHEET 1 OF 1
	<b>A</b>